



# Profile systems

## ALUTECH ALT 111

Interior partition system







**ALUTECH ALT 111**  
Interior partition system

<b>SYSTEM DESCRIPTION</b>	<b>01</b>
<b>ORDER INFORMATION</b>	<b>02</b>
<b>SYSTEM PROFILES</b>	<b>03</b>
<b>ACCESSORIES</b>	<b>04</b>
<b>GASKETS</b>	<b>05</b>
<b>GLASS INSTALLATION</b>	<b>06</b>
<b>GLASS SUPPORTS INSTALLATION</b>	<b>07</b>
<b>PARTITION FRAMES ASSEMBLAGE</b>	<b>08</b>
<b>PARTITION SECTIONS</b>	<b>09</b>
<b>DOORS. SECTIONS. PROCESSING AND ASSEMBLAGE</b>	<b>10</b>
<b>TOP HUNG SLIDING DOOR</b>	<b>11</b>
<b>ROLLER SHUTTERS. INSTALLATION. SECTIONS</b>	<b>12</b>
<b>WINDOW BLIND. INSTALLATION</b>	<b>13</b>
<b>STATICS</b>	<b>14</b>





**ALUTECH ALT 111**  
Interior partition system

## System description

01

02

03

04

05

06

07

08

09

10

11

12

13

14



The ALT111 interior partition system is designed for office spaces, shopping malls, expo centres, etc. Main advantages of the system:

- easy installation/dismantling;
- max. partition height 4 m;
- a variety of design options.

The key feature of the system is the highly effective geometry characteristics of the aluminium profiles: lower weight, smaller size and higher inertial parameters due to the unique way of infill fixation. The key element is a plastic clamp that is available in two options – symmetric and asymmetric.

Clamps are spaced 250–300 mm apart alongside the profile.

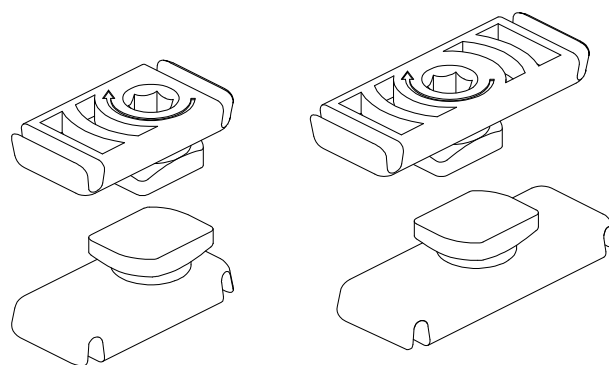

Asymmetrical clamp allows to install each infill unit individually. Such clamp is used as a main fixing element on rotary profiles and as a temporary element on other system profiles.

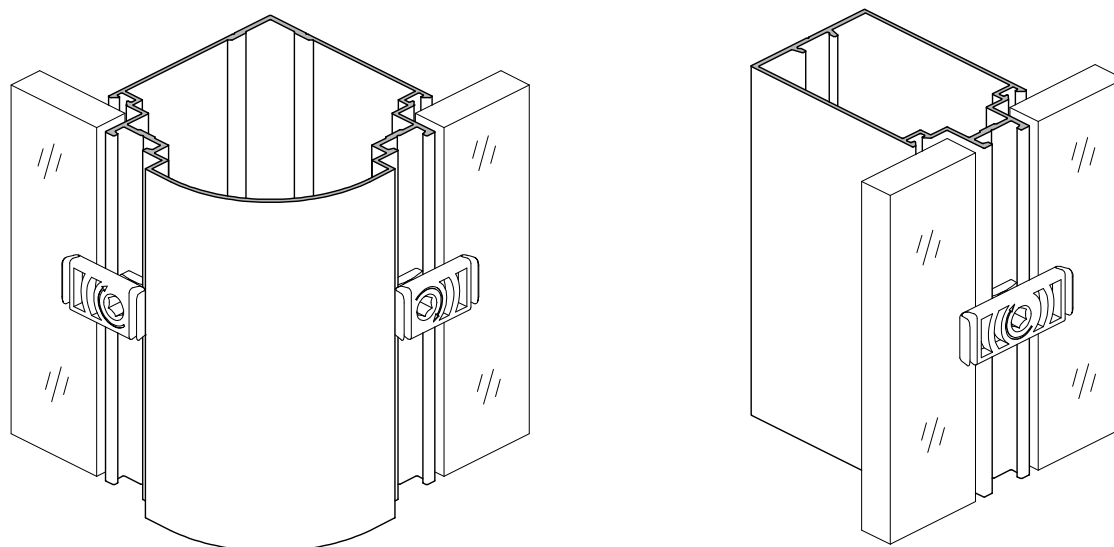

Assymetrical clamp can be also used as an option in case if the symmetrical one is not available.

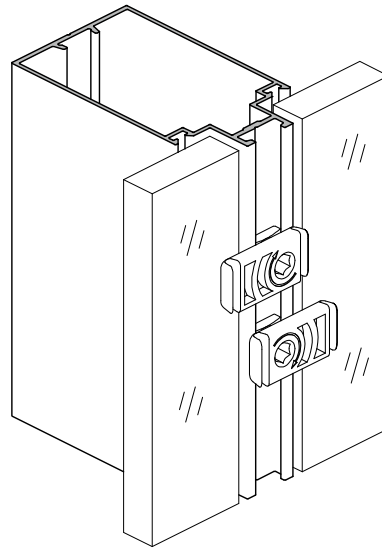

The ALT111 is the system of mullions and transoms connected with face mounted brackets. The bottom fixation of the vertical mullion is made on horizontal bar fastened to the floor. This way of mounting gives additional rigidity to a partition without connection to the ceiling.

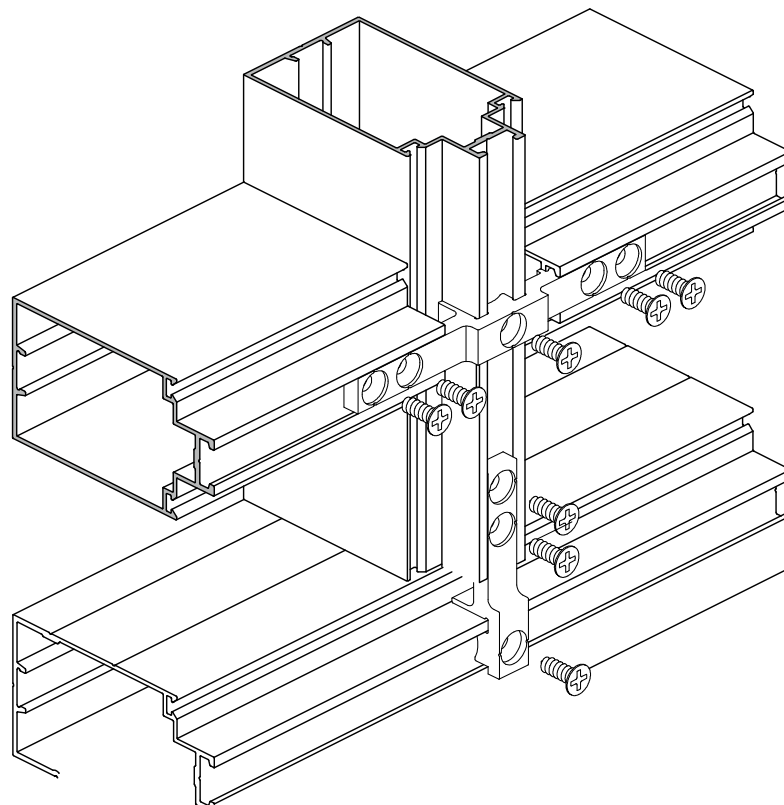



All system profiles are to be cut at 90 degrees—no milling, drilling and no need to use specialized punching equipment.

The range of infill units: 4 to 12.5 mm.

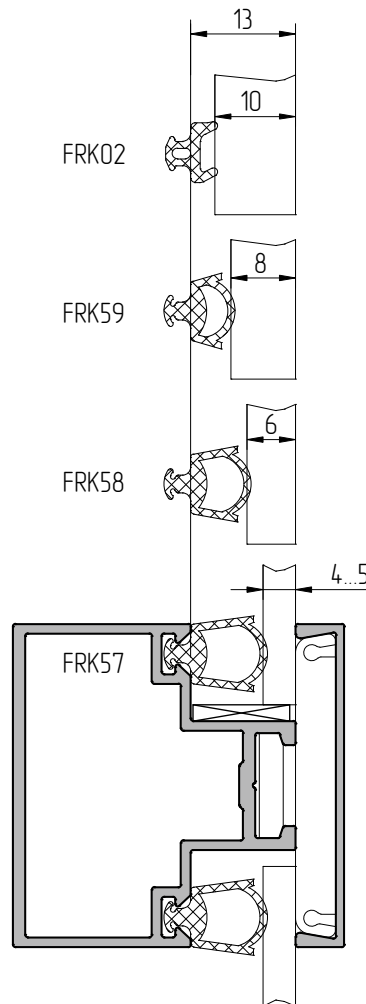





**ALUTECH ALT 111**  
Interior partition system

## Order information

01

02

03

04

05

06

07

08

09

10

11

12

13

14

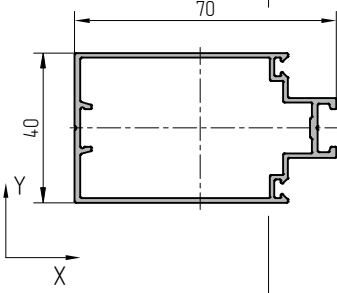
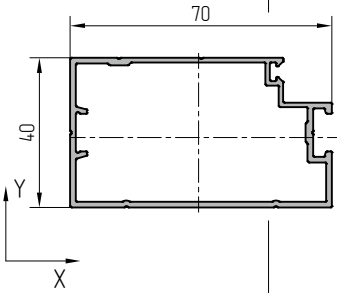
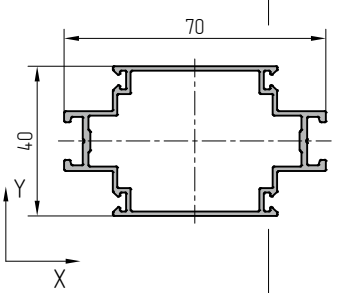
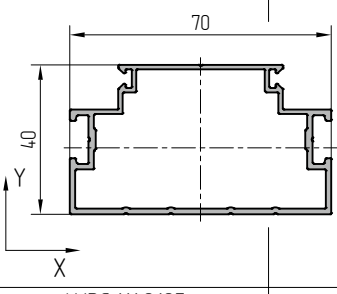
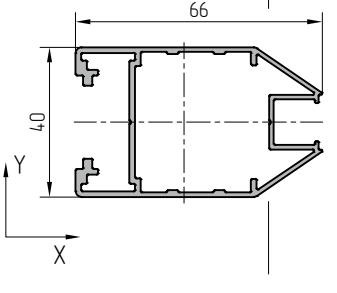

Article Image	Weight, kg/m	J <sub>x</sub> , cm <sup>4</sup>	W <sub>x</sub> , cm <sup>3</sup>	J <sub>y</sub> , cm <sup>4</sup>	W <sub>y</sub> , cm <sup>3</sup>	External perimeter, mm	Cross- section area, cm <sup>2</sup>	Code	Profile colour	Bar length, m	Pack quantity		Pack weight	
											pcs	m	net, kg	gross, kg
AYPC.111.0101 	0.827	6.86	3.43	18.83	5.17	252.4	3.063	10500100 10500169 105001806 10500121 10500130	00 RAL9006 A00-E6 RAL9016 RAL8017	6.2	6	37.2	30.8 31.9 30.8 31.9 31.9	31.8 32.9 31.8 32.9 32.9
AYPC.111.0102 	0.909	8.09	3.85	22.06	6.20	244.0	3.367	10500200 10500269 105002806 10500221 10500230	00 RAL9006 A00-E6 RAL9016 RAL8017	6.2	6	37.2	33.8 34.9 33.8 34.9 34.9	34.8 35.9 34.8 35.9 35.9
AYPC.111.0103 	0.850	6.00	3.00	15.93	4.55	285.0	3.150	10500300 10500369 105003806 10500321 10500330	00 RAL9006 A00-E6 RAL9016 RAL8017	6.2	6	37.2	316 329 316 329 329	324 337 324 337 337
AYPC.111.0104 	0.922	7.48	3.40	20.43	5.84	267.8	3.415	10500400 10500469 105004806 10500421 10500430	00 RAL9006 A00-E6 RAL9016 RAL8017	6.2	6	37.2	34.3 35.5 34.3 35.5 35.5	35.2 36.4 35.2 36.4 36.4
AYPC.111.0105 	0.958	8.13	4.07	16.09	4.35	316.6	3.550	10501800 10501869 105018806 10501821 10501830	00 RAL9006 A00-E6 RAL9016 RAL8017	6.2	4	24.8	23.8 24.7 23.8 24.7 24.7	24.5 25.4 24.5 25.4 25.4

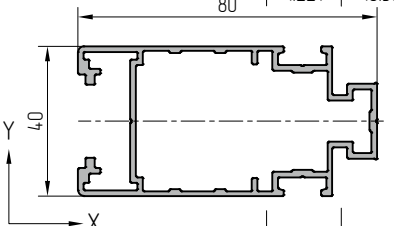
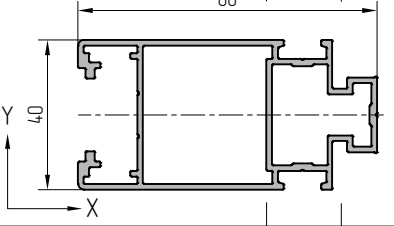
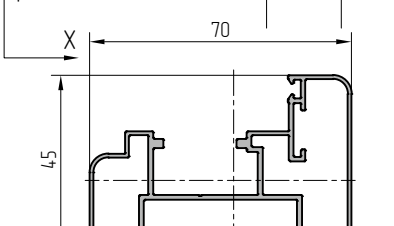
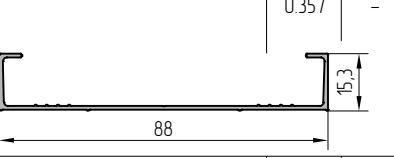
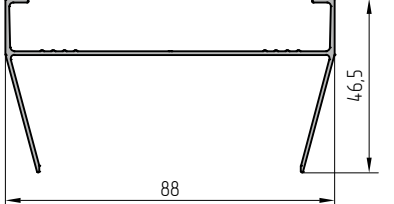
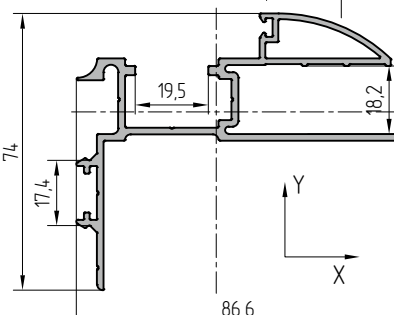
Article Image	Weight, kg/m	J <sub>x</sub> , cm <sup>4</sup>	W <sub>x</sub> , cm <sup>3</sup>	J <sub>y</sub> , cm <sup>4</sup>	W <sub>y</sub> , cm <sup>3</sup>	External perimeter, mm	Cross- section area, cm <sup>2</sup>	Code	Profile colour	Bar length, m	Pack quantity		Pack weight	
											pcs	m	net, kg	gross, kg
 <p>AYPC.111.0106</p>	1221	10.30	5.1	32.51	7.9	374.0	4.520	10501900	00	6.2	4	24.8	30.3	31.1
								10501969	RAL9006				31.4	32.2
								105019806	A00-E6				30.3	31.1
								10501921	RAL9016				31.4	32.2
								10501930	RAL8017				31.4	32.2
 <p>AYPC.111.0106M</p>	1351	10.80	5.4	32.8	8.2	368.0	5.00	10504900	00	6.2	4	24.8	33.5	34.3
								10504969	RAL9006				34.6	35.4
								105049808	A00-D6				33.5	34.3
								10504921	RAL9016				34.6	35.4
								10504930	RAL8017				34.6	35.4
 <p>AYPC.111.0107</p>	1027	6.7	2.81	18.0	4.86	284.3	3.803	10502000	00	6.2	4	24.8	25.5	26.2
								10502069	RAL9006				26.3	27.0
								105020806	A00-E6				25.5	26.2
								10502021	RAL9016				26.3	27.0
								10502030	RAL8017				26.3	27.0
 <p>AYPC.111.0108</p>	0.357	-	-	-	-	253.7	1.321	10502800	00	6.2	6	37.2	13.3	13.9
								10502869	RAL9006				14.4	15.0
								105028806	A00-E6				13.3	13.9
								10502821	RAL9016				14.4	15.0
								10502830	RAL8017				14.4	15.0
 <p>AYPC.111.0109</p>	0.531	-	-	-	-	380.1	1.965	10502900	00	6.2	2	12.4	6.6	7.1
								10502969	RAL9006				7.1	7.7
								105029806	A00-E6				6.6	7.1
								10502921	RAL9016				7.1	7.7
								10502930	RAL8017				7.1	7.7
 <p>AYPC.111.0110</p>	1409	4100	8.60	8.87	1.80	509.3	5.200	10503100	00	6.2	4	24.8	33.8	34.4
								10503169	RAL9006				35.2	35.9
								105031806	A00-E6				33.8	34.4
								10503121	RAL9016				35.2	35.9
								10503130	RAL8017				35.2	35.9

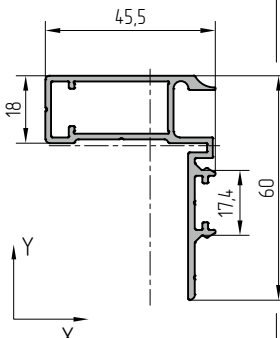
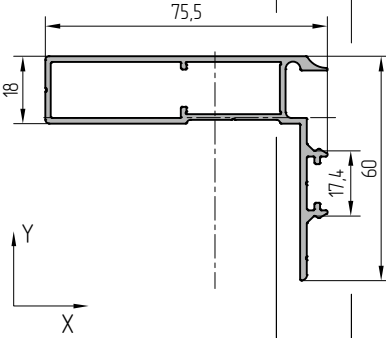
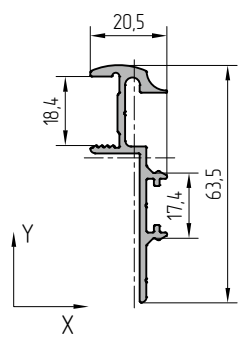
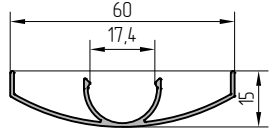
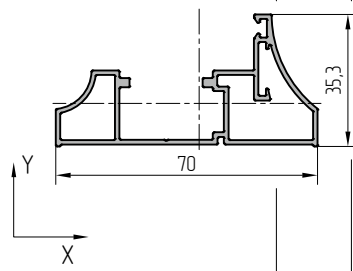
Article Image	Weight, kg/m	J <sub>x</sub> , cm <sup>4</sup>	W <sub>x</sub> , cm <sup>3</sup>	J <sub>y</sub> , cm <sup>4</sup>	W <sub>y</sub> , cm <sup>3</sup>	External perimeter, mm	Cross- section area, cm <sup>2</sup>	Code	Profile colour	Bar length, m	Pack quantity		Pack weight	
											pcs	m	net, kg	gross, kg
AYPC.111.0111 	0.814	10.73	3.83	3.49	0.85	266.9	3.005	10503200 10503269 105032806 10503221 10503230	00 RAL9006 A00-E6 RAL9016 RAL8017	6.2	4	24.8	18.7 19.4 18.7 19.4 19.4	19.3 20.0 19.3 20.0 20.0
AYPC.111.0112 	1.021	25.80	5.92	6.26	1.38	307.6	3.769	10503300 10503369 105033806 10503321 10503230	00 RAL9006 A00-E6 RAL9016 RAL8017	6.2	4	24.8	24.7 25.6 24.7 25.6 25.6	25.4 26.3 25.4 26.3 26.3
AYPC.111.0113 	0.576	7.30	1.88	0.3	0.25	223.2	2.125	10503400 10503469 105034806 10503421 10503430	00 RAL9006 A00-E6 RAL9016 RAL8017	6.2	4	24.8	13.8 14.4 13.8 14.4 14.4	14.1 14.7 14.1 14.7 14.7
AYPC.111.0114 	0.425	-	-	-	-	235.0	1.570	10503500 10503569 105035806 10503521 10503530	00 RAL9006 A00-E6 RAL9016 RAL8017	6.2	4	24.8	10.5 11.2 10.5 11.2 11.2	11.0 11.7 11.0 11.7 11.7
AYPC.111.0115 	0.760	13.00	11.30	2.40	0.63	262.3	2.816	10503600 10503669 105036806 10503621 10503630	00 RAL9006 A00-E6 RAL9016 RAL8017	6.2	4	24.8	18.8 19.6 18.8 19.6 19.6	19.5 20.3 19.5 20.3 20.3

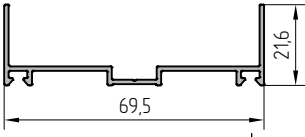
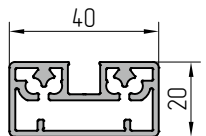
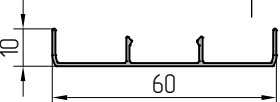
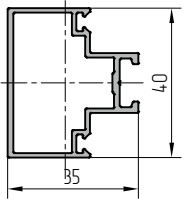
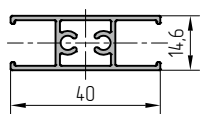
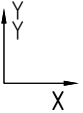
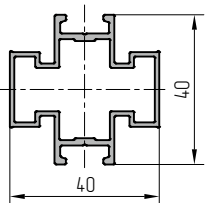
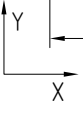
Article Image	Weight, kg/m	J <sub>x</sub> , cm <sup>4</sup>	W <sub>x</sub> , cm <sup>3</sup>	J <sub>y</sub> , cm <sup>4</sup>	W <sub>y</sub> , cm <sup>3</sup>	External perimeter, mm	Cross- section area, cm <sup>2</sup>	Code	Profile colour	Bar length, m	Pack quantity		Pack weight	
											pcs	m	net, kg	gross, kg
AYPC.111.0116 	0.420	-	-	-	-	255.6	1556	10503700	00	6.2	4	24.8	10.4	10.8
								10503769	RAL9006				11.2	11.5
								105037806	A00-E6				10.4	10.8
								10503721	RAL9016				11.2	11.5
								10503730	RAL8017				11.2	11.5
AYPC.111.0117 	0.802	-	-	-	-	135.0	2.97	10503800	00	6.2	4	24.8	19.9	20.3
								105038806	A00-E6				19.9	20.3
								105038828	A00-D6				19.9	20.3
AYPC.111.0118 	0.224	-	-	-	-	181.9	0.829	10504700	00	6.2	4	24.8	5.6	6.0
								10504769	RAL9006				6.1	6.5
								105047806	A00-E6				5.6	6.0
								10504721	RAL9016				6.1	6.5
								10504730	RAL8017				6.1	6.5
AYPC.111.0201 	0.577	3.69	185	2.9	1.48	182.3	2.137	10500500	00	6.2	6	37.2	215	22.2
								10500569	RAL9006				223	23.0
								105005806	A00-E6				215	22.2
								10500521	RAL9016				223	23.0
								10500530	RAL8017				223	23.0
AYPC.111.0202  	0.419	1.65	2.26	0.49	0.25	162.6	1551	10502100	00	4.2	2	8.4	3.5	3.8
								10502169	RAL9006				3.7	3.9
								105021806	A00-E6				3.5	3.8
								10502121	RAL9016				3.7	3.9
								10502130	RAL8017				3.7	3.9
AYPC.111.0203  	0.661	3.54	1.77	3.35	1.68	210.7	2.450	10502200	00	4.2	2	8.4	5.6	5.9
								10502269	RAL9006				5.8	6.1
								105022806	A00-E6				5.6	5.9
								10502221	RAL9016				5.8	6.1
								10502230	RAL8017				5.8	6.1

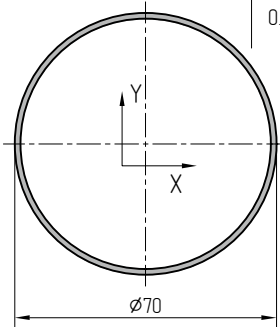
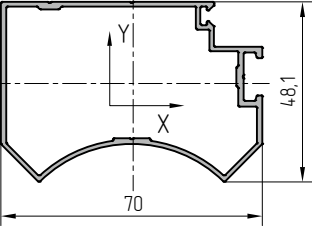
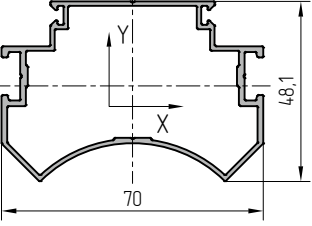
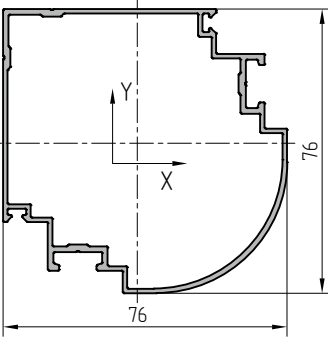

Article Image	Weight, kg/m	J <sub>x</sub> , cm <sup>4</sup>	W <sub>x</sub> , cm <sup>3</sup>	J <sub>y</sub> , cm <sup>4</sup>	W <sub>y</sub> , cm <sup>3</sup>	External perimeter, mm	Cross- section area, cm <sup>2</sup>	Code	Profile colour	Bar length, m	Pack quantity		Pack weight	
											pcs	m	net, kg	gross, kg
AYPC.111.0301 	0.872	18.94	5.41	18.94	5.41	220.0	3.228	10500600 10500669 105006806 10500621 10500630	00 RAL9006 A00-E6 RAL9016 RAL8017	6.2	2	12.4	10.8 11.1 10.8 11.1 11.1	11.4 11.7 11.4 11.7 11.7
AYPC.111.0302 	0.865	20.73	7.88	8.67	2.45	253.5	3.202	10500700 10500769 105007806 10500721 10500730	00 RAL9006 A00-E6 RAL9016 RAL8017	6.2	2	12.4	10.7 11.1 10.7 11.1 11.1	11.3 11.6 11.3 11.6 11.6
AYPC.111.0303 	0.906	20.20	7.89	8.15	2.33	277.0	3.356	10500800 10500869 105008806 10500821 10500830	00 RAL9006 A00-E6 RAL9016 RAL8017	6.2	2	12.4	11.2 11.6 11.2 11.6 11.6	11.7 12.1 11.7 12.1 12.1
AYPC.111.0304 	1.139	31.85	7.94	28.90	7.21	335.8	4.218	10500900 10500969 105009806 10500921 10500930	00 RAL9006 A00-E6 RAL9016 RAL8017	6.2	2	12.4	14.1 14.6 14.1 14.6 14.6	14.8 15.3 14.8 15.3 15.3

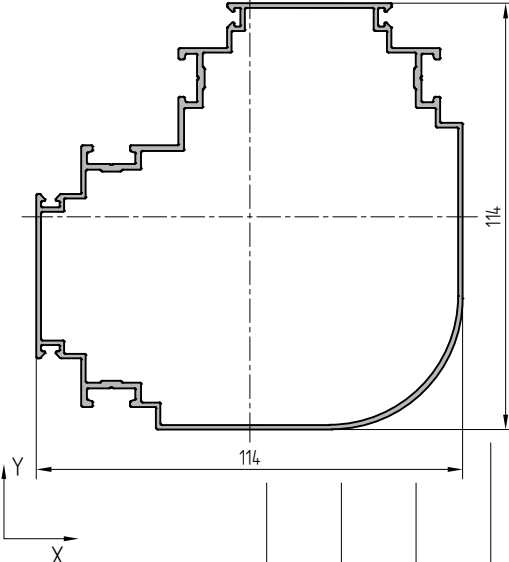
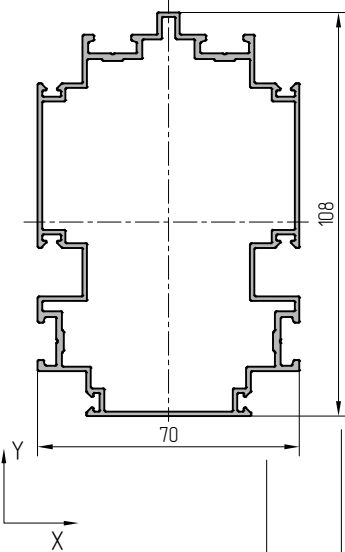
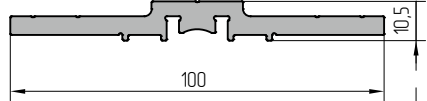
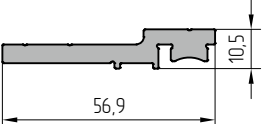
Article Image	Weight, kg/m	J <sub>x</sub> , cm <sup>4</sup>	W <sub>x</sub> , cm <sup>3</sup>	J <sub>y</sub> , cm <sup>4</sup>	W <sub>y</sub> , cm <sup>3</sup>	External perimeter, mm	Cross- section area, cm <sup>2</sup>	Code	Profile colour	Bar length, m	Pack quantity		Pack weight	
											pcs	m	net, kg	gross, kg
AYPC.111.0305  	1763	119.64	20.95	82.68	14.48	534.4	6.530	10501000	00	6.2	2	12.4	219	22.8
								10501069	RAL9006				22.7	23.6
								105010806	A00-E6				219	22.8
								10501021	RAL9016				22.7	23.6
								10501030	RAL8017				22.7	23.6
AYPC.111.0306  	1631	77.14	13.75	39.92	11.41	515.0	6.040	10502700	00	6.2	2	12.4	20.2	20.9
								10502769	RAL9006				21.0	21.6
								105027806	A00-E6				20.2	20.9
								10502721	RAL9016				21.0	21.6
								10502730	RAL8017				21.0	21.6
AYPC.111.0401  	1517	-	-	-	-	249.0	5.617	10501100	00	3	6	18.0	27.3	27.6
AYPC.111.0402  	0.884	-	-	-	-	147.2	3.273	10501200	00	3	6	18.0	15.9	16.1

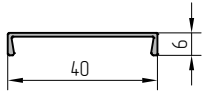
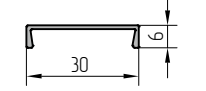
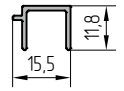
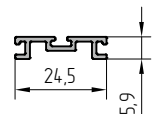
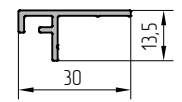
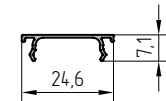
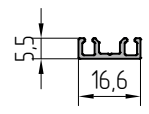
Article Image	Weight, kg/m	J <sub>x</sub> , cm <sup>4</sup>	W <sub>x</sub> , cm <sup>3</sup>	J <sub>y</sub> , cm <sup>4</sup>	W <sub>y</sub> , cm <sup>3</sup>	External perimeter, mm	Cross- section area, cm <sup>2</sup>	Code	Profile colour	Bar length, m	Pack quantity		Pack weight	
											pcs	m	net, kg	gross, kg
AYPC.111.0501 	0.145	-	-	-	-	101.7	0.538	10501500	00	6.2	10	62.0	9.0	9.3
10501569								RAL9006	9.7				10.3	
105015806								A00-E6	9.0				9.3	
10501521								RAL9016	9.7				10.3	
10501530								RAL8017	9.7				10.3	
AYPC.111.0502 	0.118	-	-	-	81.7	0.438	10501600	00	6.2	10	62.0	7.3	7.6	
10501669							RAL9006	7.9				8.2		
105016806							A00-E6	7.3				7.6		
10501621							RAL9016	7.9				8.2		
10501630							RAL8017	7.9				8.2		
AYPC.111.0503 	0.120	-	-	-	74.5	0.444	10501700	00	6.2	4	24.8	3.0	3.1	
10501769							RAL9006	3.2				3.3		
105017806							A00-E6	3.0				3.1		
10501721							RAL9016	3.2				3.3		
10501730							RAL8017	3.2				3.3		
AYPC.111.0601 	0.155	-	-	-	94.9	57.4	10502300	00	4.2	2	8.4	1.3	1.4	
10502369							RAL9006	1.4				1.5		
105023806							A00-E6	1.3				1.4		
10502321							RAL9016	1.4				1.5		
10502330							RAL8017	1.4				1.5		
AYPC.111.0602 	0.203	-	-	-	102.0	0.750	10502600	00	4.5	4	18.0	3.7	3.8	
10502669							RAL9006	3.9				4.0		
105026806							A00-E6	3.7				3.8		
10502621							RAL9016	3.9				4.0		
10502630							RAL8017	3.9				4.0		
AYPC.111.0605 	0.088	-	-	-	79.3	0.327	10503000	00	6.2	4	24.8	2.2	2.4	
10503069							RAL9006	2.4				2.6		
105030806							A00-E6	2.2				2.4		
10503021							RAL9016	2.4				2.6		
10503030							RAL8017	2.4				2.6		
AYPC.C48.0628 	0.107	-	-	-	71.2	0.396	10405300	00	6.5	12	78	8.3	8.7	
10405331							RAL9006	9.2				9.7		
104053806							A00-E6	8.3				8.7		
10405321							RAL9016	9.2				9.7		
10405324							RAL8014	9.2				9.7		
10405330							RAL8017	9.2				9.7		

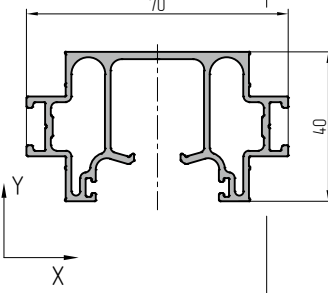
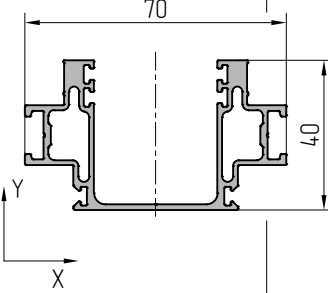
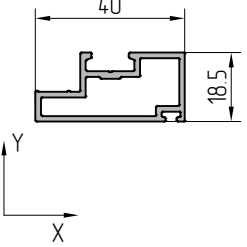
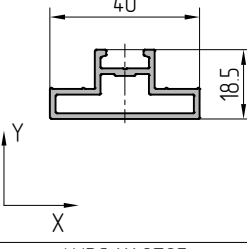
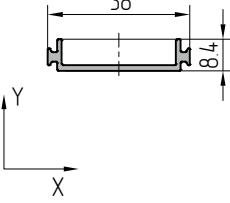
Article Image	Weight, kg/m	J <sub>x</sub> , cm <sup>4</sup>	W <sub>x</sub> , cm <sup>3</sup>	J <sub>y</sub> , cm <sup>4</sup>	W <sub>y</sub> , cm <sup>3</sup>	External perimeter, mm	Cross- section area, cm <sup>2</sup>	Code	Profile colour	Bar length, m	Pack quantity		Pack weight	
											pcs	m	net, kg	gross, kg
AYPC.111.0701 	1294	7.8	2.23	213	9.56	364.9	4.793	10503900	00	6.2	4	24.8	32.1	33.2
								10503969	RAL9006				32.8	33.9
								105039806	A00-E6				32.1	33.2
								10503921	RAL9016				32.8	33.9
								10503930	RAL8017				32.8	33.9
AYPC.111.0702 	1056	6.2	1.77	19.8	9.08	375.2	4.28	10504000	00	6.2	4	24.8	28.7	29.8
								10504069	RAL9006				29.3	30.5
								105040806	A00-E6				28.7	29.8
								10504021	RAL9016				29.3	30.5
								10504030	RAL8017				29.3	30.5
AYPC.111.0703 	0.507	0.8	1.74	2.9	2.79	139.8	1.878	10504100	00	6.2	4	24.8	12.6	13.0
								10504169	RAL9006				13.0	13.4
								105041806	A00-E6				12.6	13.0
								10504121	RAL9016				13.0	13.4
								10504130	RAL8017				13.0	13.4
AYPC.111.0704 	0.472	0.5	0.25	2.4	2.05	131.8	1.75	10504200	00	6.2	4	24.8	11.7	12.1
								10504269	RAL9006				12.1	12.5
								105042806	A00-E6				11.7	12.1
								10504221	RAL9016				12.1	12.5
								10504230	RAL8017				12.1	12.5
AYPC.111.0705 	0.222	0.04	0.02	14	2.26	110.6	0.820	10504300	00	6.2	8	49.6	11.0	11.7
								10504369	RAL9006				11.4	12.1
								105043806	A00-E6				11.0	11.7
								10504321	RAL9016				11.4	12.1
								10504330	RAL8017				11.4	12.1

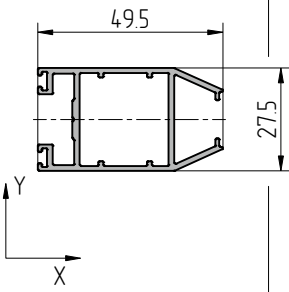
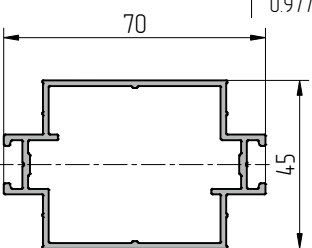
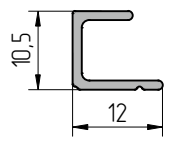
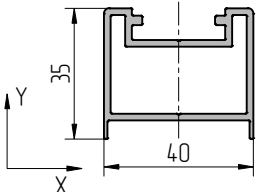
Article Image	Weight, kg/m	J <sub>x</sub> , cm <sup>4</sup>	W <sub>x</sub> , cm <sup>3</sup>	J <sub>y</sub> , cm <sup>4</sup>	W <sub>y</sub> , cm <sup>3</sup>	External perimeter, mm	Cross- section area, cm <sup>2</sup>	Code	Profile colour	Bar length, m	Pack quantity		Pack weight	
											pcs	m	net, kg	gross, kg
AYPC.111.0706 	0.682	2.8	1.03	5.5	4.00	245.8	2.525	10504400	00	6.2	4	24.8	16.9	17.6
								10504469	RAL9006				17.5	18.2
								105044806	A00-E6				16.9	17.6
								10504421	RAL9016				17.5	18.2
								10504430	RAL8017				17.5	18.2
AYPC.111.0707 	0.977	9.3	2.66	18.9	8.40	260.2	3.626	10504500	00	6.2	4	24.8	24.3	25.1
								10504569	RAL9006				25.0	25.8
								105045806	A00-E6				24.3	25.1
								10504521	RAL9016				25.0	25.8
								10504530	RAL8017				25.0	25.8
AYPC.111.0708 	0.089	-	-	-	-	56.1	0.33	10504600	00	6.2	8	49.6	4.4	4.7
								10504669	RAL9006				4.6	4.9
								105046806	A00-E6				4.4	4.7
								10504621	RAL9016				4.6	4.9
								10504630	RAL8017				4.6	4.9
AYPC.111.0709 	0.789	3.4	1.74	6.5	3.25	184.6	0.292	10504800	00	6.2	4	24.8	19.6	20.1
								10504869	RAL9006				20.1	20.6
								105048806	A00-E6				19.6	20.1
								10504821	RAL9016				20.1	20.6
								10504830	RAL8017				20.1	20.6





**ALUTECH ALT 111**  
Interior partition system

## System profiles

01

02

03

04

05

06

07

08

09

10

11

12

13

14





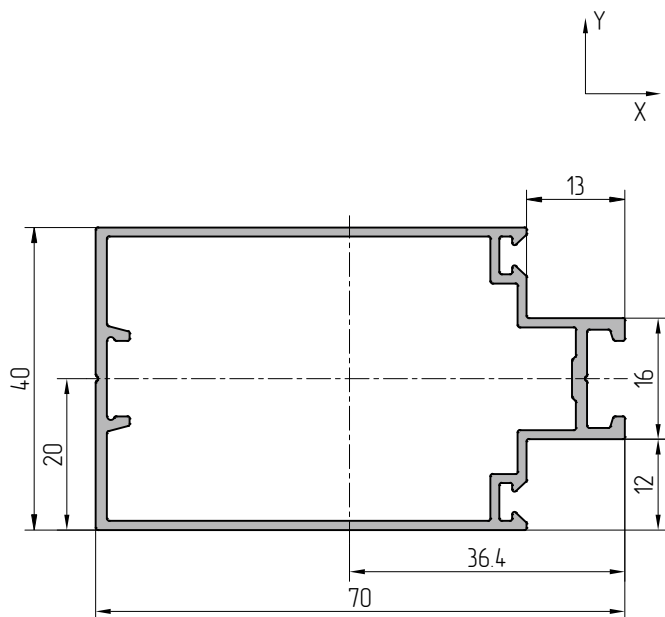

Scale 11	Mullion profile			
AYPC.111.0101	Article	Central moment of inertia		
0.83 kg	Theoretical weight 1 m	$J_x=6.9 \text{ cm}^4$	$J_y=18.8 \text{ cm}^4$	
252 mm	External perimeter	Moment of resistance		
306 mm <sup>2</sup>	Cross-section area	$W_x=3.43 \text{ cm}^3$	$W_y=5.17 \text{ cm}^3$	

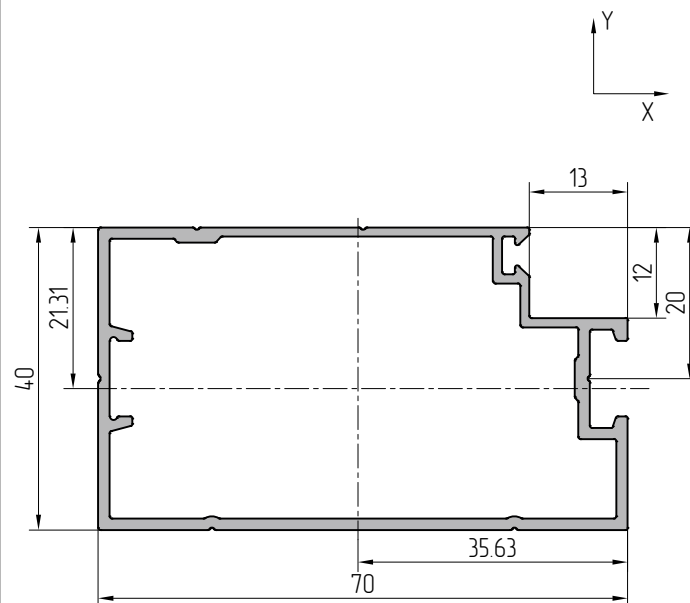

Scale 11	Frame profile			
AYPC.111.0102	Article	Central moment of inertia		
0.91 kg	Theoretical weight 1 m	$J_x=8.2 \text{ cm}^4$	$J_y=22.8 \text{ cm}^4$	
244 mm	External perimeter	Moment of resistance		
337 mm <sup>2</sup>	Cross-section area	$W_x=3.85 \text{ cm}^3$	$W_y=6.20 \text{ cm}^3$	

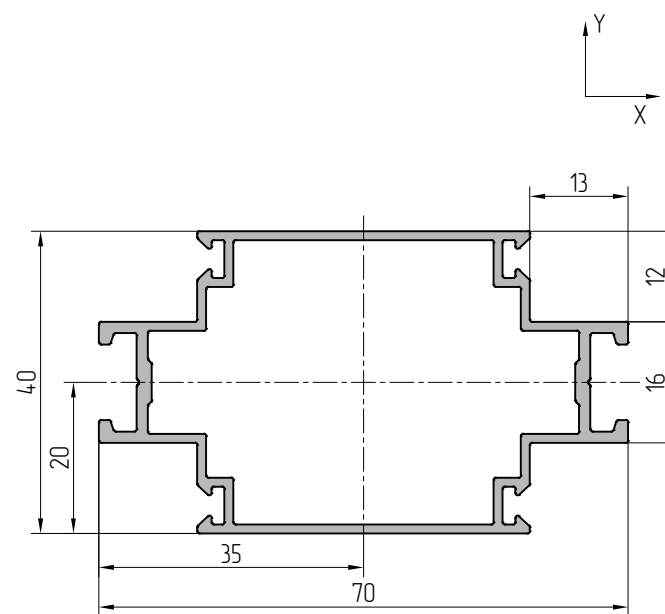

Scale 11	Mullion profile			
AYPC.111.0103	Article	Central moment of inertia		
0.85 kg	Theoretical weight 1 m	$J_x=6.0 \text{ cm}^4$	$J_y=15.93 \text{ cm}^4$	
285 mm	External perimeter	Moment of resistance		
315 mm <sup>2</sup>	Cross-section area	$W_x=3.0 \text{ cm}^3$	$W_y=4.55 \text{ cm}^3$	

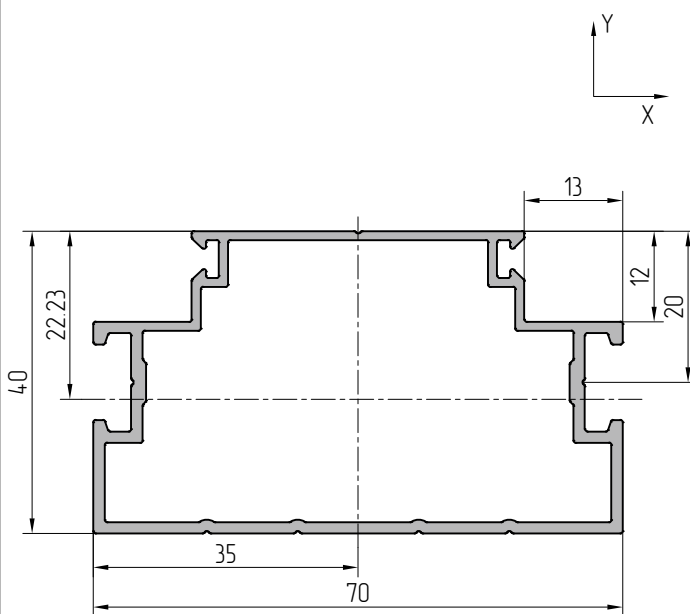

Scale 11	Frame profile			
AYPC.111.0104	Article	Central moment of inertia		
0.92 kg	Theoretical weight 1 m	$J_x=7.5 \text{ cm}^4$	$J_y=20.4 \text{ cm}^4$	
268 mm	External perimeter	Moment of resistance		
342 mm <sup>2</sup>	Cross-section area	$W_x=3.85 \text{ cm}^3$	$W_y=6.20 \text{ cm}^3$	

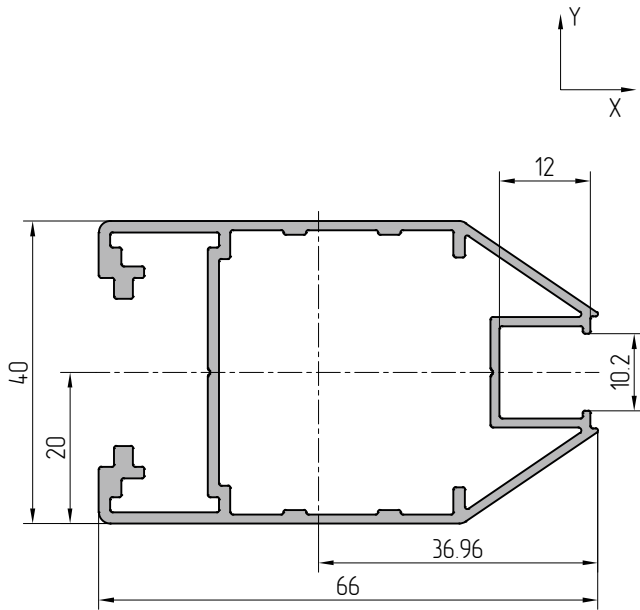

Scale 11	Leaf profile		
AYPC.111.0105	Article	Central moment of inertia	
0.96 kg	Theoretical weight 1 m	Jx=8.1 cm <sup>4</sup>	Jy=15.8 cm <sup>4</sup>
317 mm	External perimeter	Moment of resistance	
355 mm <sup>2</sup>	Cross-section area	Wx=4.07 cm <sup>3</sup>	Wy=4.35 cm <sup>3</sup>

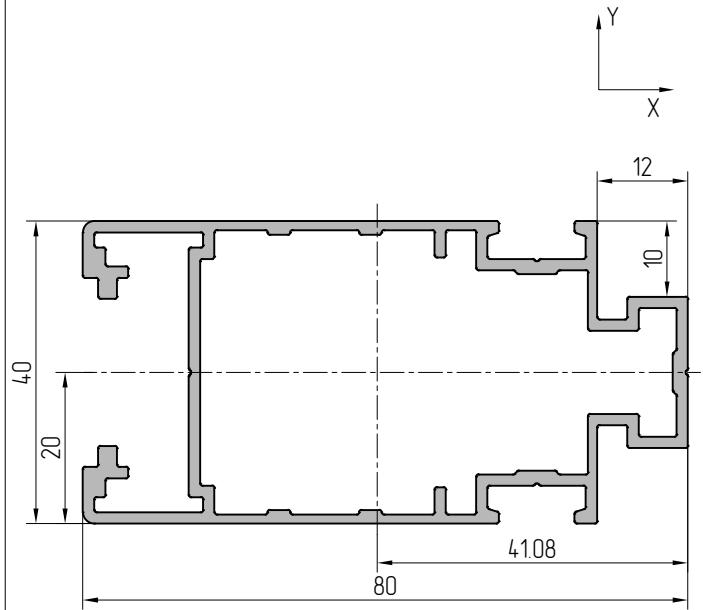

Scale 11	Leaf profile		
AYPC.111.0106	Article	Central moment of inertia	
1.22 kg	Theoretical weight 1 m	Jx=10.2 cm <sup>4</sup>	Jy=32.3 cm <sup>4</sup>
374 mm	External perimeter	Moment of resistance	
452 mm <sup>2</sup>	Cross-section area	Wx=5.1 cm <sup>3</sup>	Wy=7.9 cm <sup>3</sup>

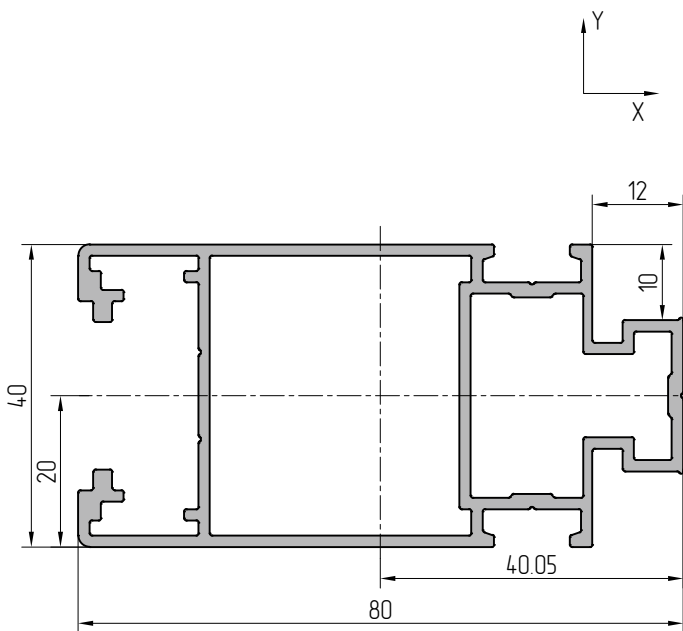

Scale 11	Leaf profile		
AYPC.111.0106M	Article	Central moment of inertia	
1.351 kg	Theoretical weight 1 m	Jx=10.8 cm <sup>4</sup>	Jy=32.8 cm <sup>4</sup>
368 mm	External perimeter	Moment of resistance	
500 mm <sup>2</sup>	Cross-section area	Wx=5.4 cm <sup>3</sup>	Wy=8.2 cm <sup>3</sup>

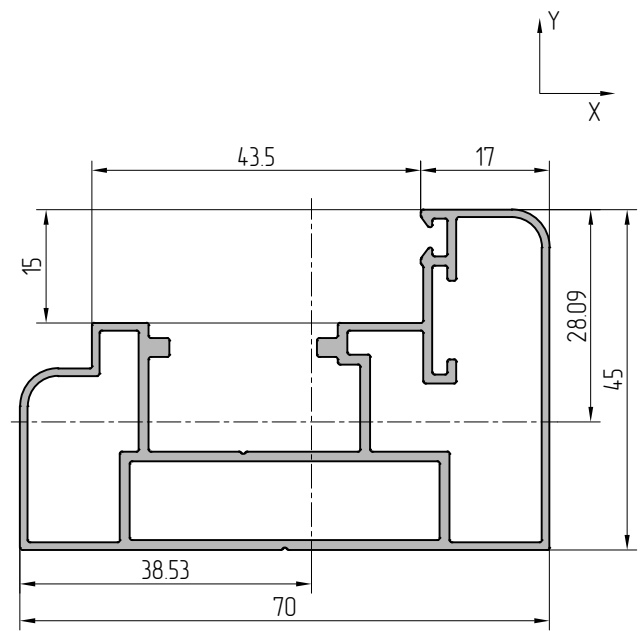

Scale 11	Frame profile		
AYPC.111.0107	Article	Central moment of inertia	
1.03 kg	Theoretical weight 1 m	Jx=6.7 cm <sup>4</sup>	Jy=18.0 cm <sup>4</sup>
284 mm	External perimeter	Moment of resistance	
380 mm <sup>2</sup>	Cross-section area	Wx=2.81 cm <sup>3</sup>	Wy=4.86 cm <sup>3</sup>

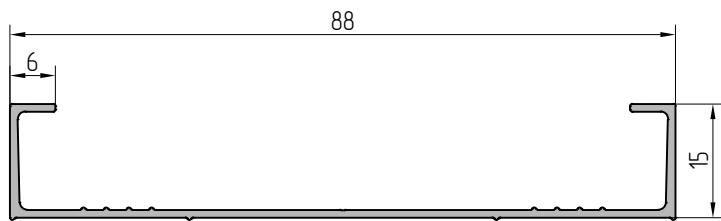

Scale 1:1		Adapter profile	
AYPC.111.0108	Article		
0.36 kg	Theoretical weight 1 m		
254 mm	External perimeter		
132 mm <sup>2</sup>	Cross-section area		

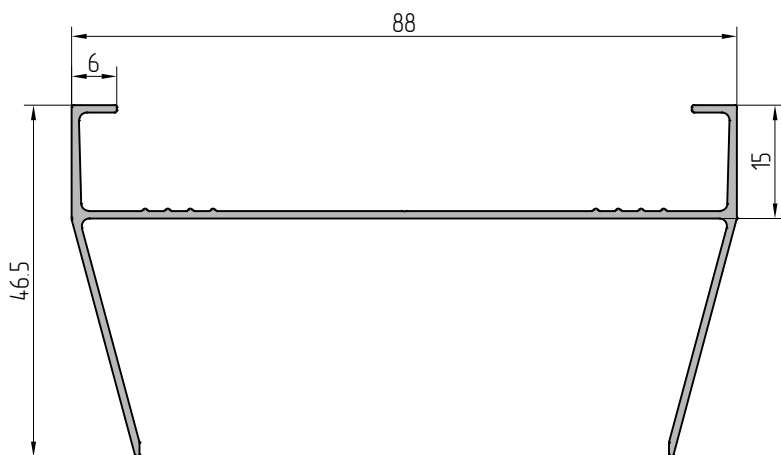

Scale 1:1		Adapter profile	
AYPC.111.0109	Article		
0.53 kg	Theoretical weight 1 m		
380 mm	External perimeter		
197 mm <sup>2</sup>	Cross-section area		

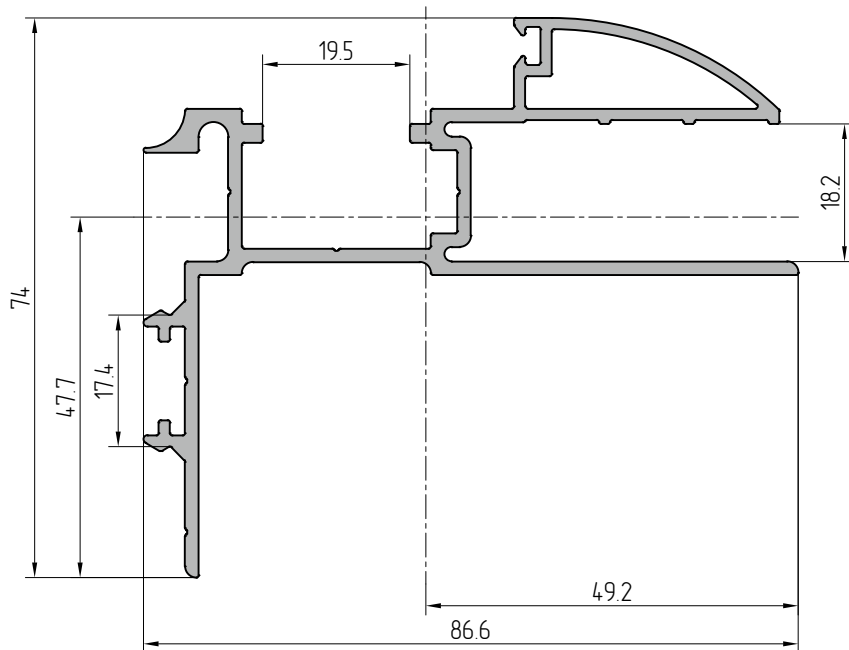

Scale 1:1		Frame profile	
AYPC.111.0110	Article	Central moment of inertia	
1.409 kg	Theoretical weight 1 m	Jx=4100 cm <sup>4</sup>	Jy=8.87 cm <sup>4</sup>
5093 mm	External perimeter	Moment of resistance	
5200 mm <sup>2</sup>	Cross-section area	Wx=8.60 cm <sup>3</sup>	Wy=1.80 cm <sup>3</sup>

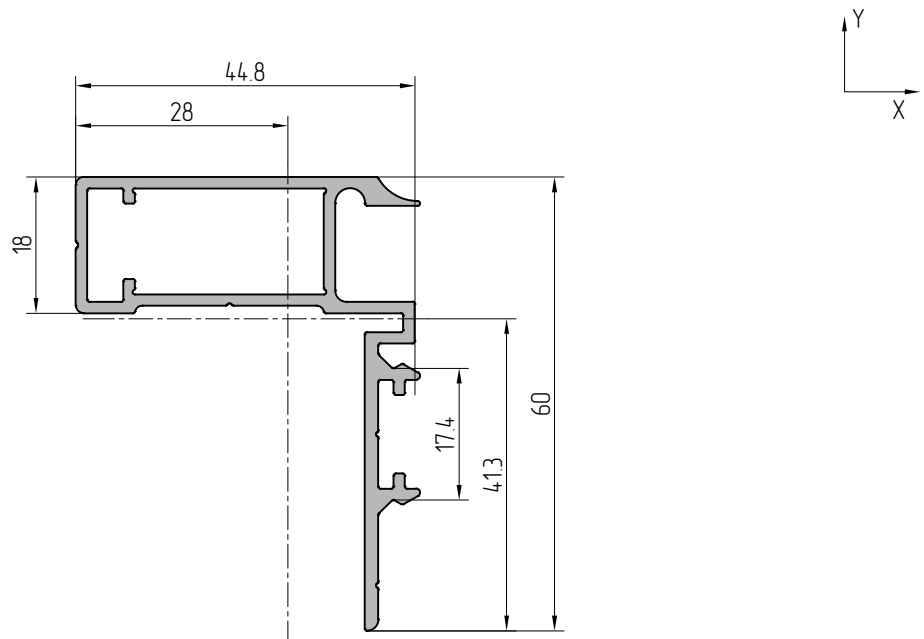

Scale 1:1		Frame profile	
AYPC.111.0111	Article	Central moment of inertia	
0.814 kg	Theoretical weight 1 m	Jx=10.73 cm <sup>4</sup>	Jy=3.49 cm <sup>4</sup>
266.9 mm	External perimeter	Moment of resistance	
300.5 mm <sup>2</sup>	Cross-section area	Wx=3.83 cm <sup>3</sup>	Wy=0.85 cm <sup>3</sup>

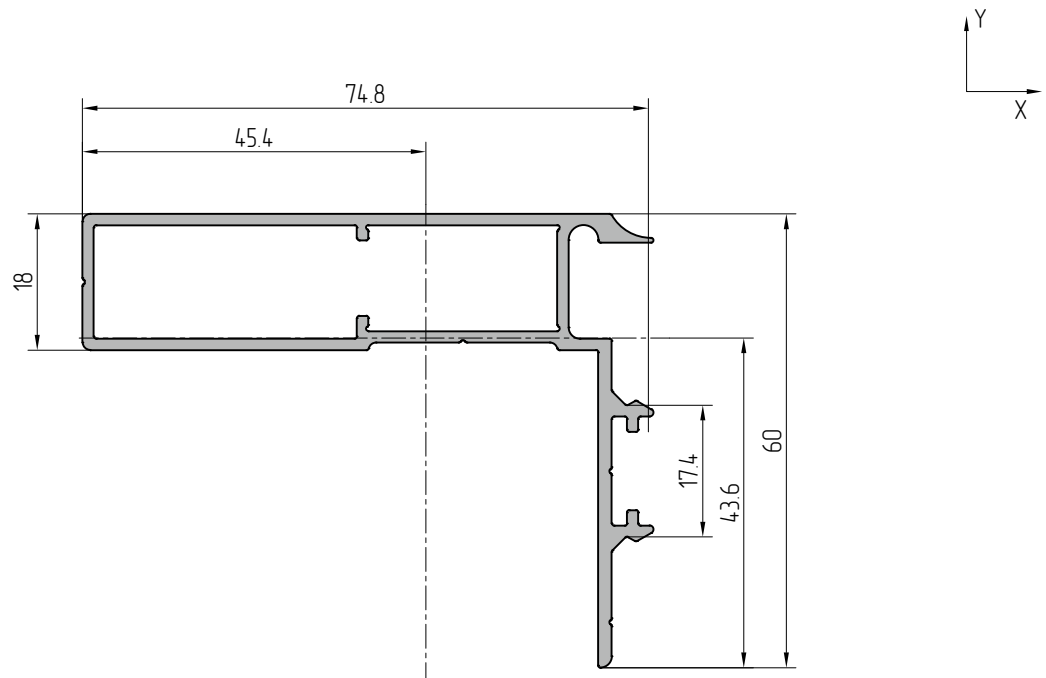

Scale 1:1		Frame profile	
AYPC.111.0112	Article	Central moment of inertia	
1.021 kg	Theoretical weight 1 m	Jx=25.80 cm <sup>4</sup>	Jy=6.26 cm <sup>4</sup>
307.6 mm	External perimeter	Moment of resistance	
376.9 mm <sup>2</sup>	Cross-section area	Wx=5.92 cm <sup>3</sup>	Wy=1.38 cm <sup>3</sup>

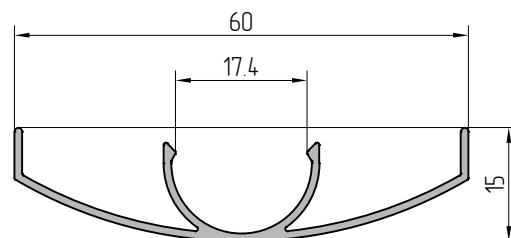
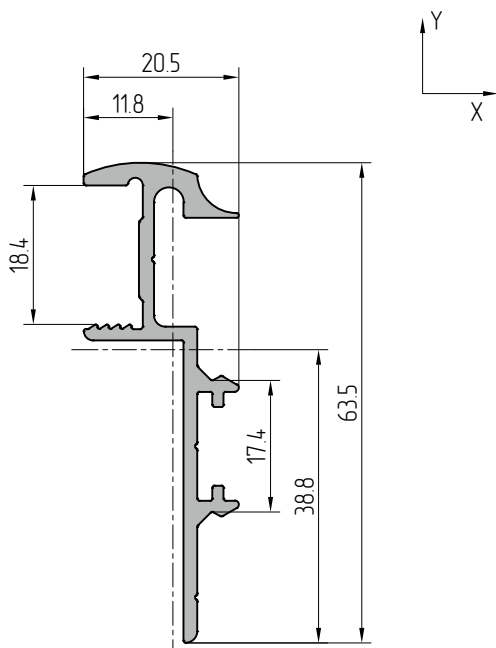

Scale 1:1		Frame profile		Scale 1:1		Frame profile	
AYPC.111.0113	Article	Central moment of inertia		AYPC.111.0114	Article		
0.576 kg	Theoretical weight 1 m	$J_x=7.3 \text{ cm}^4$	$J_y=0.3 \text{ cm}^4$	0.425 kg	Theoretical weight 1 m		
223.2 mm	External perimeter	Moment of resistance		235.0 mm	External perimeter		
212.5 mm <sup>2</sup>	Cross-section area	$W_x=1.88 \text{ cm}^3$	$W_y=0.25 \text{ cm}^3$	157.0 mm <sup>2</sup>	Cross-section area		

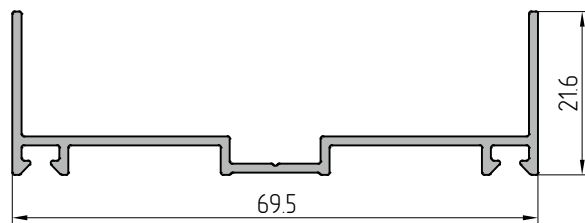
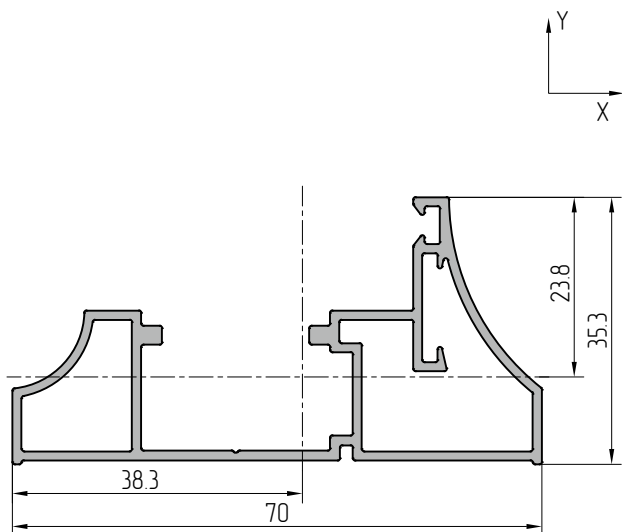

Scale 1:1		Frame profile		Scale 1:1		Cover cap profile	
AYPC.111.0115	Article	Central moment of inertia		AYPC.111.0116	Article		
0.760 kg	Theoretical weight 1 m	$J_x=13.00 \text{ cm}^4$	$J_y=2.40 \text{ cm}^4$	0.420 kg	Theoretical weight 1 m		
262.3 mm	External perimeter	Moment of resistance		255.6 mm	External perimeter		
281.6 mm <sup>2</sup>	Cross-section area	$W_x=11.3 \text{ cm}^3$	$W_y=0.63 \text{ cm}^3$	155.6 mm <sup>2</sup>	Cross-section area		

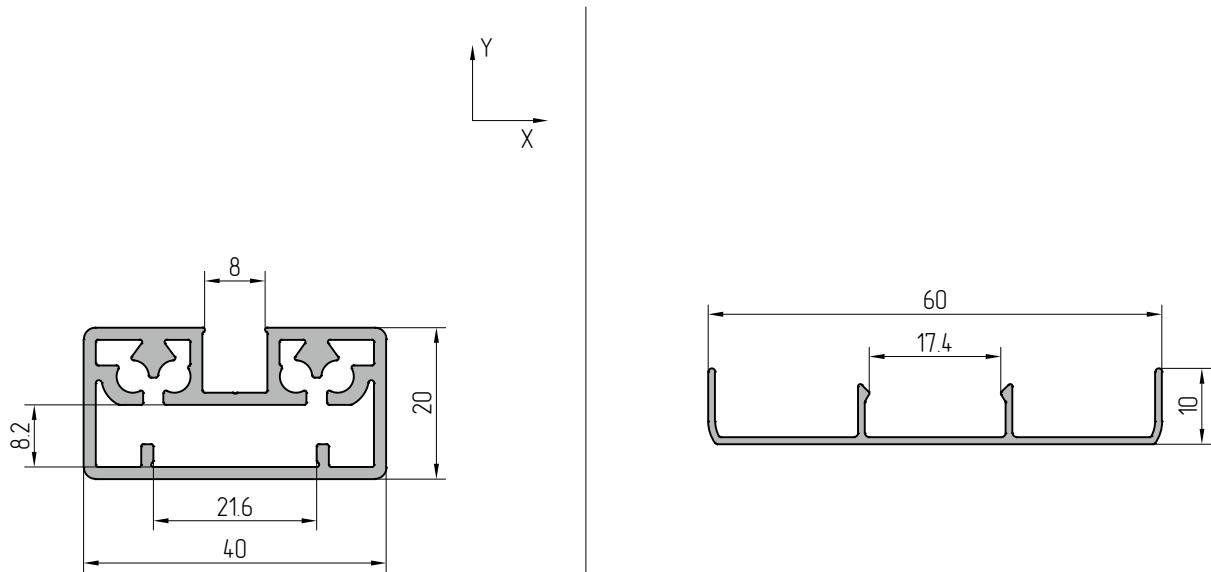

Scale 1:1		Leaf profile		Scale 1:1		Cover cap profile	
AYPC.111.0117	Article	Central moment of inertia		AYPC.111.0118	Article		
0.802 kg	Theoretical weight 1 m	$J_x=1.3 \text{ cm}^4$	$J_y=5.1 \text{ cm}^4$	0.224 kg	Theoretical weight 1 m		
135.0 mm	External perimeter	Moment of resistance		181.9 mm	External perimeter		
297.0 mm <sup>2</sup>	Cross-section area	$W_x=1.2 \text{ cm}^3$	$W_y=2.55 \text{ cm}^3$	82.9 mm <sup>2</sup>	Cross-section area		

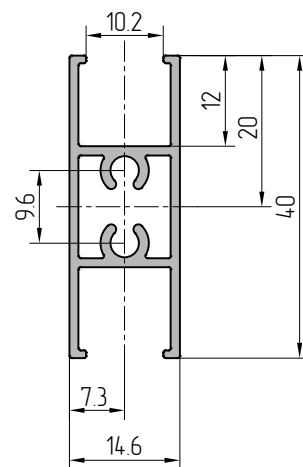
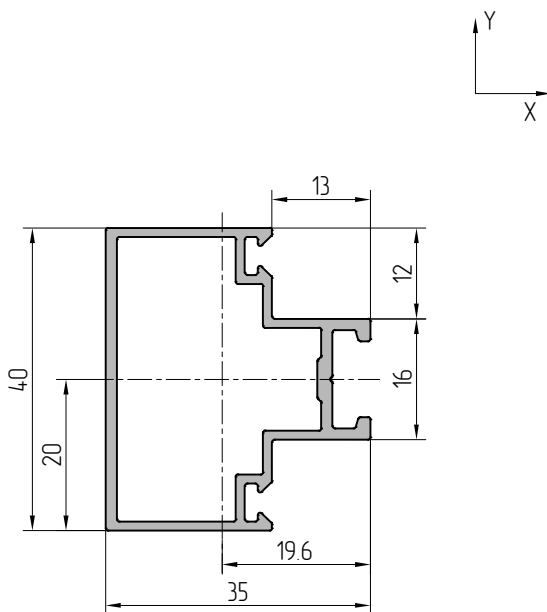

Scale 11	Transom profile		
AYPC.111.0201	Article	Central moment of inertia	
0.58 kg	Theoretical weight 1 m	$J_x=2.9 \text{ cm}^4$	$J_y=3.7 \text{ cm}^4$
182 mm	External perimeter	Moment of resistance	
214 mm <sup>2</sup>	Cross-section area	$W_x=185 \text{ cm}^3$	$W_y=148 \text{ cm}^3$

Scale 11	Transom profile		
AYPC.111.0202	Article	Central moment of inertia	
0.42 kg	Theoretical weight 1 m	$J_x=1.8 \text{ cm}^4$	$J_y=0.49 \text{ cm}^4$
163 mm	External perimeter	Moment of resistance	
155 mm <sup>2</sup>	Cross-section area	$W_x=0.25 \text{ cm}^3$	$W_y=2.26 \text{ cm}^3$

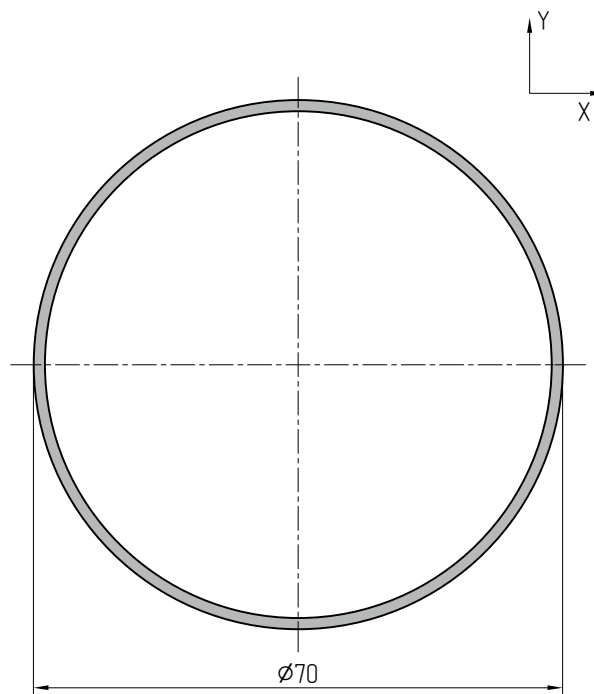
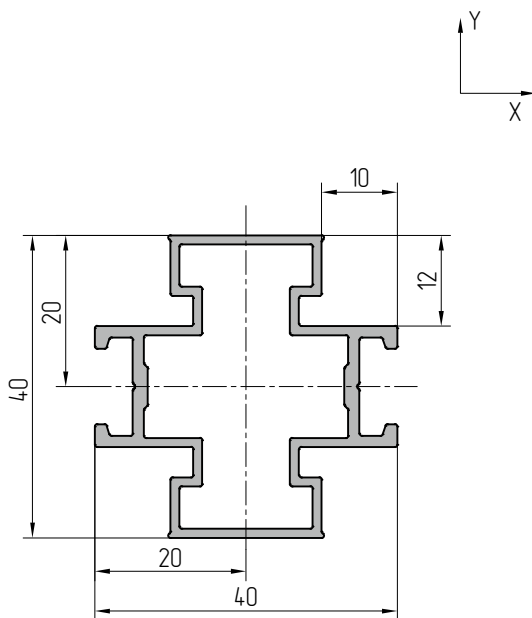

Scale 11	Transom profile		
AYPC.111.0203	Article	Central moment of inertia	
0.66 kg	Theoretical weight 1 m	$J_x=3.5 \text{ cm}^4$	$J_y=3.3 \text{ cm}^4$
210 mm	External perimeter	Moment of resistance	
245 mm <sup>2</sup>	Cross-section area	$W_x=168 \text{ cm}^3$	$W_y=177 \text{ cm}^3$

Scale 11	Tube profile		
AYPC.111.0301	Article	Central moment of inertia	
0.87 kg	Theoretical weight 1 m	$J_x=18.9 \text{ cm}^4$	$J_y=18.9 \text{ cm}^4$
220 mm	External perimeter	Moment of resistance	
323 mm <sup>2</sup>	Cross-section area	$W_x=5.41 \text{ cm}^3$	$W_y=5.41 \text{ cm}^3$

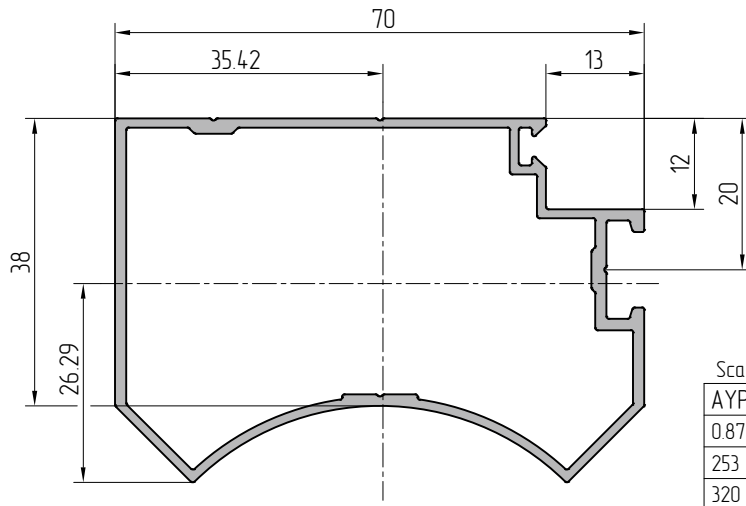

Scale 1:1		Rotary profile	
AYPC.111.0302	Article	Central moment of inertia	
0.87 kg	Theoretical weight 1 m	$J_x=8.8 \text{ cm}^4$	$J_y=20.6 \text{ cm}^4$
253 mm	External perimeter	Moment of resistance	
320 mm <sup>2</sup>	Cross-section area	$W_x=7.88 \text{ cm}^3$	$W_y=2.45 \text{ cm}^3$

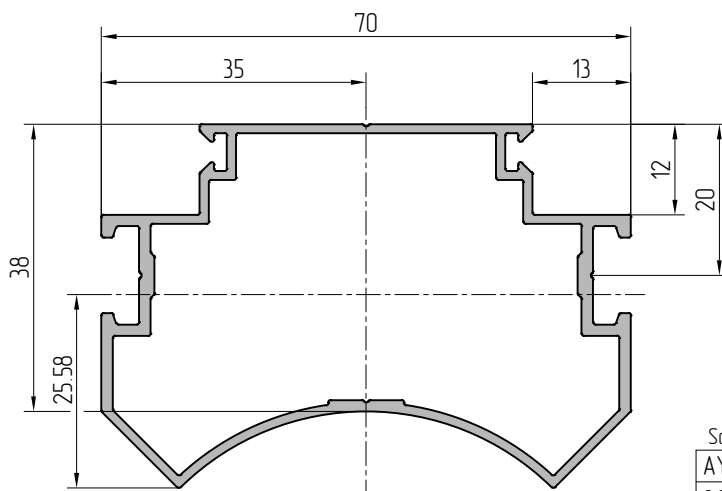

Scale 1:1		Rotary profile	
AYPC.111.0303	Article	Central moment of inertia	
0.91 kg	Theoretical weight 1 m	$J_x=8.1 \text{ cm}^4$	$J_y=20.2 \text{ cm}^4$
277 mm	External perimeter	Moment of resistance	
336 mm <sup>2</sup>	Cross-section area	$W_x=7.89 \text{ cm}^3$	$W_y=2.33 \text{ cm}^3$

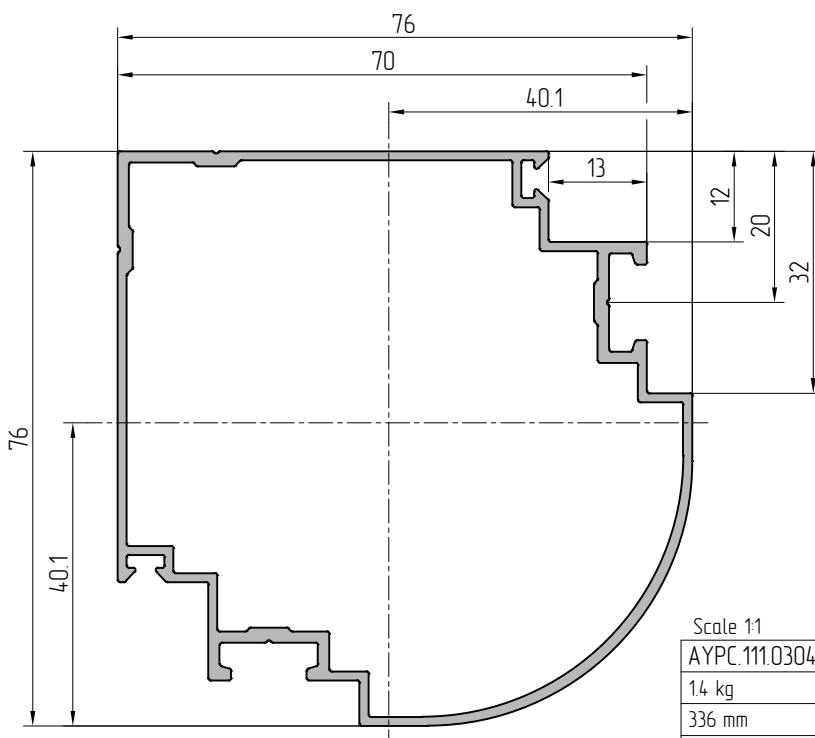

Scale 1:1		Rotary profile	
AYPC.111.0304	Article	Central moment of inertia	
14 kg	Theoretical weight 1 m	$J_x=30.4 \text{ cm}^4$	$J_y=30.4 \text{ cm}^4$
336 mm	External perimeter	Moment of resistance	
422 mm <sup>2</sup>	Cross-section area	$W_x=7.94 \text{ cm}^3$	$W_y=7.21 \text{ cm}^3$



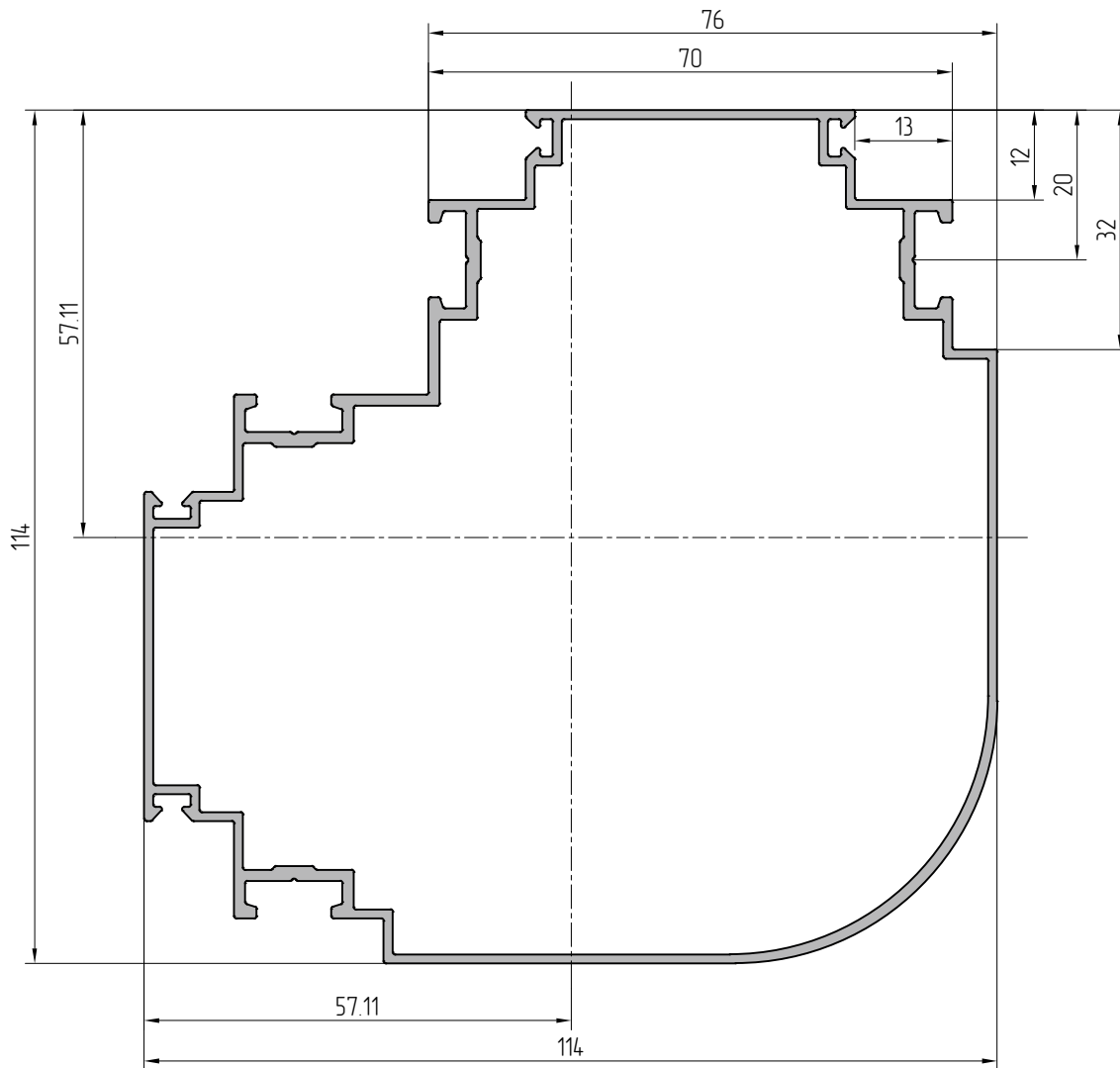
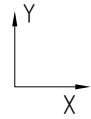

Scale 1:1	Rotary profile	
A YPC.111.0305	Article	Central moment of inertia
1.76 kg	Theoretical weight 1 m	J <sub>x</sub> =1012 cm <sup>4</sup>   J <sub>y</sub> =1012 cm <sup>4</sup>
534 mm	External perimeter	Moment of resistance
635 mm <sup>2</sup>	Cross-section area	W <sub>x</sub> =20.95 cm <sup>3</sup>   W <sub>y</sub> =14.48 cm <sup>3</sup>

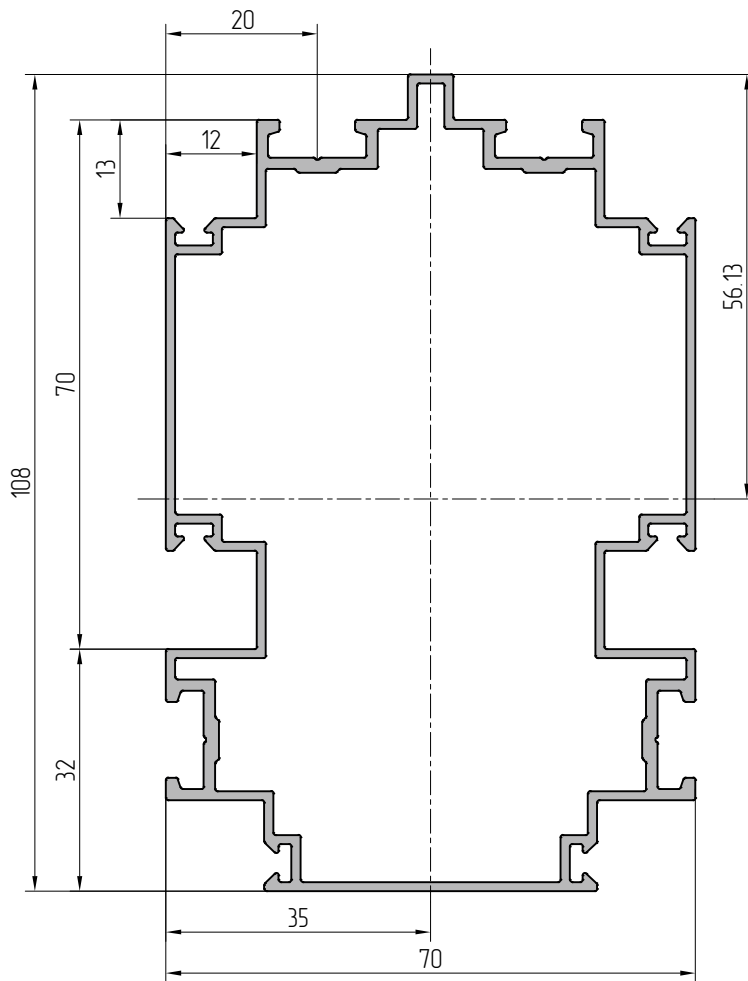

Scale 1:1	Connecting profile		
AYPC.111.0306	Article	Central moment of inertia	
163 kg	Theoretical weight 1 m	$J_x=77.0 \text{ cm}^4$	$J_y=40.0 \text{ cm}^4$
515 mm	External perimeter	Moment of resistance	
604 mm <sup>2</sup>	Cross-section area	$W_x=13.75 \text{ cm}^3$	$W_y=11.41 \text{ cm}^3$

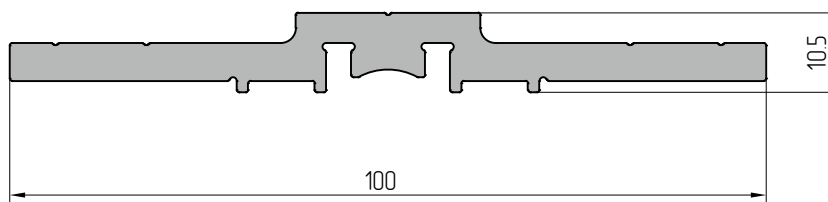

Scale 1:1	Bracket profile
AYPC.111.0401	Article
1517 kg	Theoretical weight 1 m
249.0 mm	External perimeter
561.7 mm <sup>2</sup>	Cross-section area

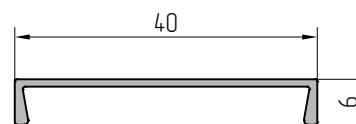
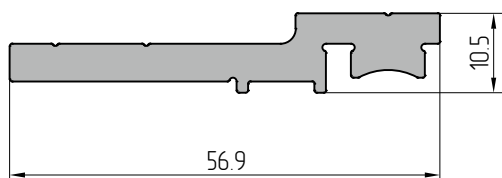

Scale 1:1	Bracket profile
AYPC.111.0402	Article
0.884 kg	Theoretical weight 1 m
147.2 mm	External perimeter
327.3 mm <sup>2</sup>	Cross-section area

Scale 1:1	Cover cap profile
AYPC.111.0501	Article
0.14 kg	Theoretical weight 1 m
102 mm	External perimeter
54 mm <sup>2</sup>	Cross-section area

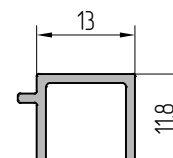
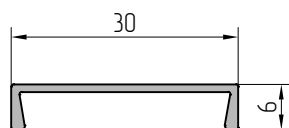

Scale 1:1	Cover cap profile
AYPC.111.0502	Article
0.12 kg	Theoretical weight 1 m
82 mm	External perimeter
44 mm <sup>2</sup>	Cross-section area

Scale 1:1	Cover cap profile
AYPC.111.0503	Article
0.12 kg	Theoretical weight 1 m
75 mm	External perimeter
44 mm <sup>2</sup>	Cross-section area

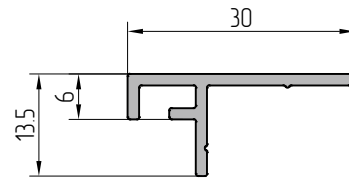
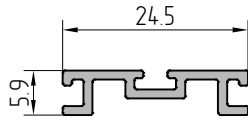

Scale 1:1	Holder profile	Scale 1:1	Double casement profile
AYPC.111.0601	Article	AYPC.111.0602	Article
0.15 kg	Theoretical weight 1 m	0.20 kg	Theoretical weight 1 m
95 mm	External perimeter	102 mm	External perimeter
57 mm <sup>2</sup>	Cross-section area	75 mm <sup>2</sup>	Cross-section area

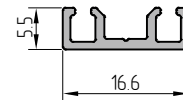
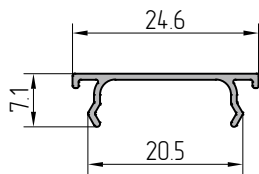

Scale 1:1	Cover cap profile	Scale 1:1	Door adjoining profile
AYPC.111.0605	Article	AYPC.C48.0628	Article
0.088 kg	Theoretical weight 1 m	0.107 kg	Theoretical weight 1 m
79.3 mm	External perimeter	71.2 mm	External perimeter
32.7 mm <sup>2</sup>	Cross-section area	39.6 mm <sup>2</sup>	Cross-section area

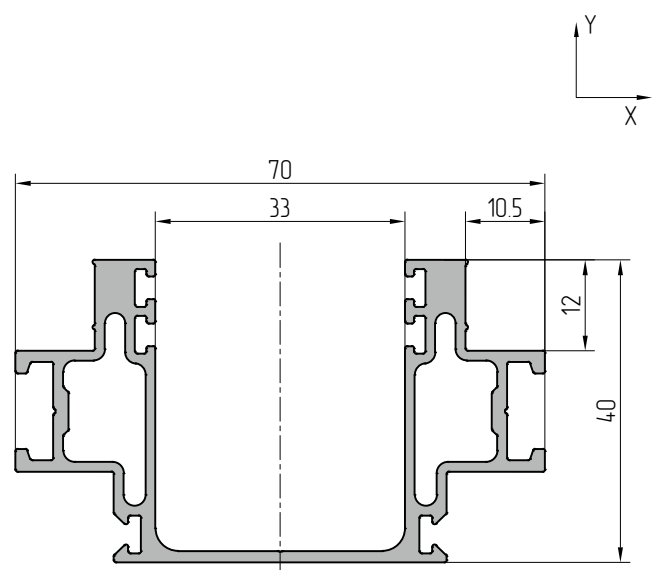
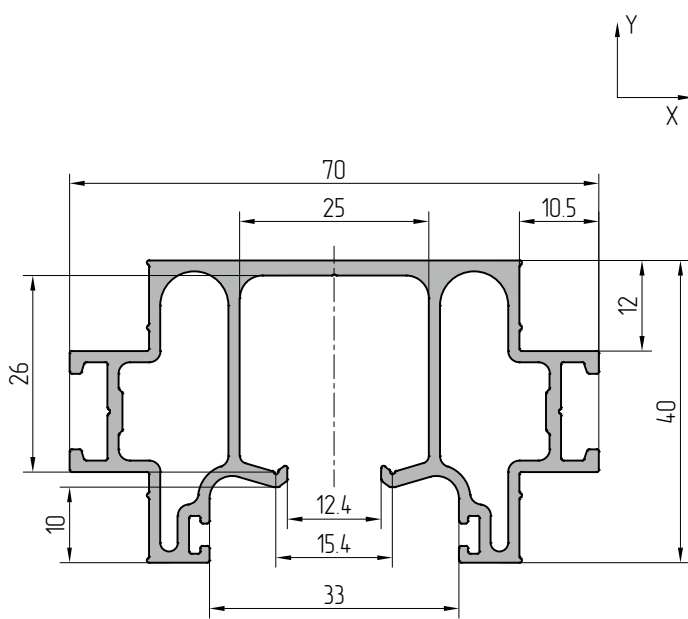

Scale 11	Guide profile		
AYPC.111.0701	Article	Central moment of inertia	
1294 kg	Theoretical weight 1 m	$J_x=7.8 \text{ cm}^4$	$J_y=21.3 \text{ cm}^4$
364.9 mm	External perimeter	Moment of resistance	
4.793 cm <sup>2</sup>	Cross-section area	$W_x=2.23 \text{ cm}^3$	$W_y=9.56 \text{ cm}^3$

Scale 11	Mullion profile		
AYPC.111.0702	Article	Central moment of inertia	
1073 kg	Theoretical weight 1 m	$J_x=6.2 \text{ cm}^4$	$J_y=19.8 \text{ cm}^4$
375.2 mm	External perimeter	Moment of resistance	
3.973 cm <sup>2</sup>	Cross-section area	$W_x=1.77 \text{ cm}^3$	$W_y=9.08 \text{ cm}^3$

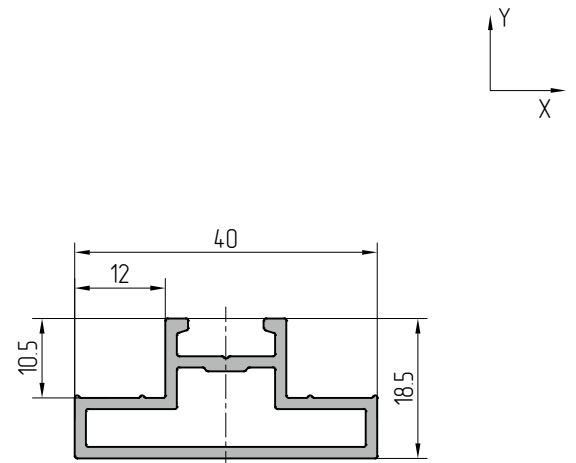
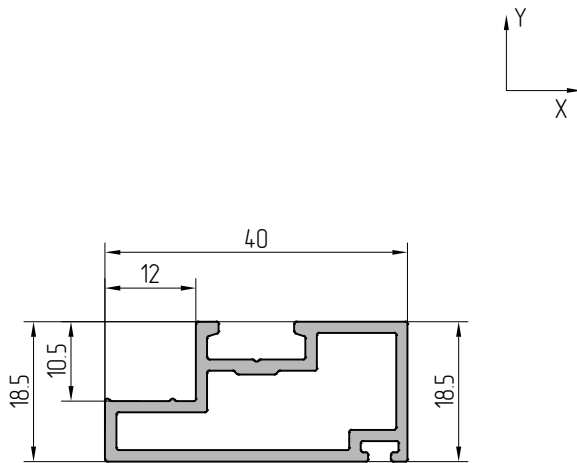

Scale 11	Mullion profile		
AYPC.111.0703	Article	Central moment of inertia	
0.507 kg	Theoretical weight 1 m	$J_x=0.8 \text{ cm}^4$	$J_y=2.9 \text{ cm}^4$
139.8 mm	External perimeter	Moment of resistance	
1.878 cm <sup>2</sup>	Cross-section area	$W_x=1.74 \text{ cm}^3$	$W_y=2.79 \text{ cm}^3$

Scale 11	Transom profile		
AYPC.111.0704	Article	Central moment of inertia	
0.472 kg	Theoretical weight 1 m	$J_x=0.5 \text{ cm}^4$	$J_y=2.4 \text{ cm}^4$
131.8 mm	External perimeter	Moment of resistance	
1.75 cm <sup>2</sup>	Cross-section area	$W_x=0.25 \text{ cm}^3$	$W_y=2.05 \text{ cm}^3$

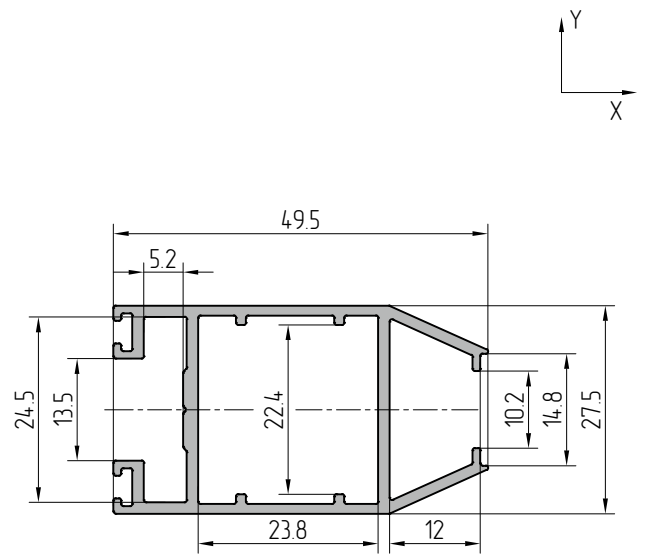
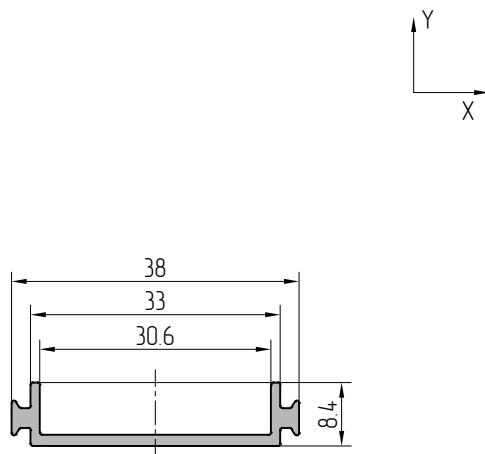

Scale 1:1	Auxiliary profile		
AYPC.111.0705	Article	Central moment of inertia	
0.222 kg	Theoretical weight 1 m	$J_x=0.04 \text{ cm}^4$	$J_y=1.4 \text{ cm}^4$
110.5 mm	External perimeter	Moment of resistance	
0.821 cm <sup>2</sup>	Cross-section area	$W_x=0.02 \text{ cm}^3$	$W_y=2.26 \text{ cm}^3$

Scale 1:1	Leaf profile		
AYPC.111.0706	Article	Central moment of inertia	
0.682 kg	Theoretical weight 1 m	$J_x=2.8 \text{ cm}^4$	$J_y=5.5 \text{ cm}^4$
245.8 mm	External perimeter	Moment of resistance	
2.527 cm <sup>2</sup>	Cross-section area	$W_x=1.03 \text{ cm}^3$	$W_y=4.00 \text{ cm}^3$

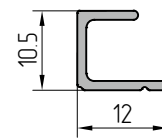
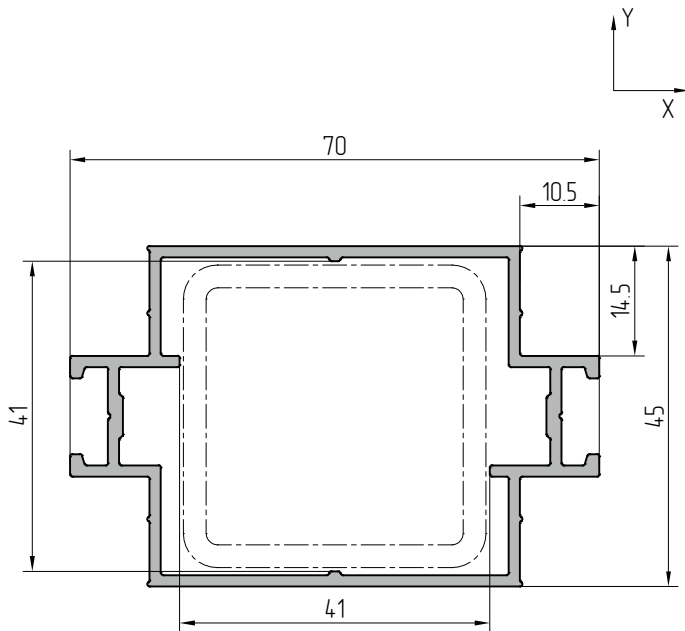

Scale 1:1	Reinforced transom profile		
AYPC.111.0707	Article	Central moment of inertia	
0.977 kg	Theoretical weight 1 m	$J_x=9.3 \text{ cm}^4$	$J_y=18.9 \text{ cm}^4$
260.2 mm	External perimeter	Moment of resistance	
3.620 cm <sup>2</sup>	Cross-section area	$W_x=2.66 \text{ cm}^3$	$W_y=8.40 \text{ cm}^3$

Scale 1:1	Glass bead profile	
AYPC.111.0708	Article	
0.089 kg	Theoretical weight 1 m	
56.1 mm	External perimeter	
0.33 cm <sup>2</sup>	Cross-section area	

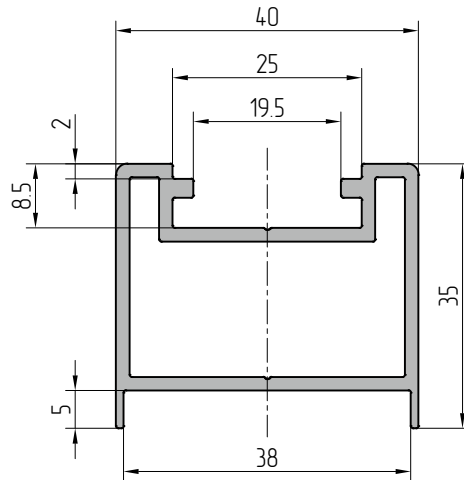
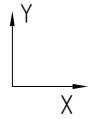

Scale 1:1	Mullion profile		
AYPC.111.0709	Article	Central moment of inertia	
0.789 kg	Theoretical weight 1 m	Jx=3.4 cm <sup>4</sup>	Jy=6.5 cm <sup>4</sup>
184.6 mm	External perimeter	Moment of resistance	
2.920 cm <sup>2</sup>	Cross-section area	Wx=1.74 cm <sup>3</sup>	Wy=3.25 cm <sup>3</sup>

- 01
- 02
- 03
- 04
- 05
- 06
- 07
- 08
- 09
- 10
- 11
- 12
- 13
- 14







**ALUTECH ALT 111**  
Interior partition system

## Accessories

01

02

03

**04**

05

06

07

08

09

10

11

12

13

14



Image	Code	Article	Application
 <p>Clamp (colour: grey) Pack quantity: 100 pcs</p>	10510200	AYPC.111.0901	
 <p>Clamp (colour: grey) Pack quantity: 100 pcs</p>	10510300	AYPC.111.0902	
 <p>Plug (colour: grey) Pack quantity: 200 pcs</p>	10510300	AYPC.111.0903	
 <p>Plug (colour: grey) Pack quantity: 20 pcs</p>	10513400	AYPC.111.0904	

Image	Code	Article	Application
 <p>Plug Pack quantity: 20 pcs</p>	10514500	AYPC.111.0905	
 <p>Plug (colour: grey) Pack quantity: 30 pcs</p>	10510900	AYPC.111.0911	
 <p>Plug (colour: grey) Pack quantity: 30 pcs</p>	10511000	AYPC.111.0912	

Image	Code	Article	Application
 <p>Plug (colour: grey) Pack quantity: 30 pcs</p>	1051100	AYPC.111.0913	
 <p>Plug (colour: grey) Pack quantity: 30 pcs</p>	1051200	AYPC.111.0914	
 <p>Plug (colour: grey) Pack quantity: 30 pcs</p>	1051700	AYPC.111.0914-01	

Image	Code	Article	Application
 <p>Plug (colour: grey) Pack quantity: 30 pcs</p>	10511600	AYPC.111.0915	
 <p>Bracket Pack quantity: 96 pcs</p>	10514700	AYPC.111.0951M	
 <p>Bracket Pack quantity: 100 pcs</p>	10514800	AYPC.111.0952M	
 <p>Bracket Pack quantity: 55 pcs</p>	10510600	AYPC.111.0953	

Image	Code	Article	Application
 <p>Joining element Pack quantity: 48 pcs</p>	10510700	AYPC.111.0954	
 <p>Joining element Pack quantity: 98 pcs</p>	10510800	AYPC.111.0955	
 <p>Joining element Pack quantity: 20 pcs</p>	105150	AYPC.111.0957	
 <p>Leveling support Pack quantity: 200 pcs</p>	10211400	AYPC.110.0901	
	10211500	AYPC.110.0902	
	10211600	AYPC.110.0903	
	10211700	AYPC.110.0905	

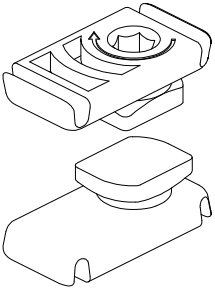
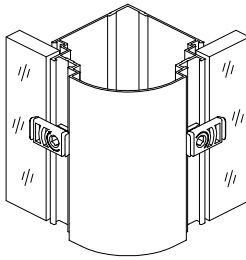
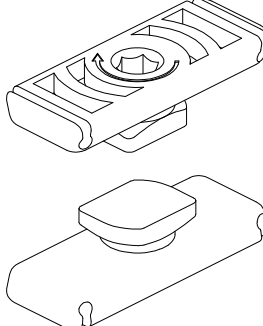
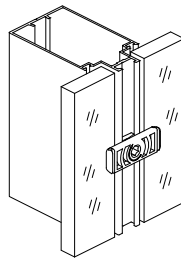
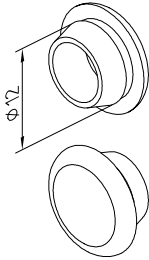
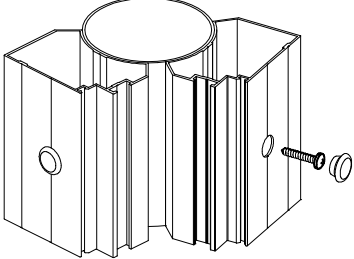
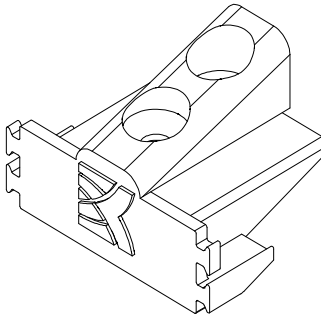
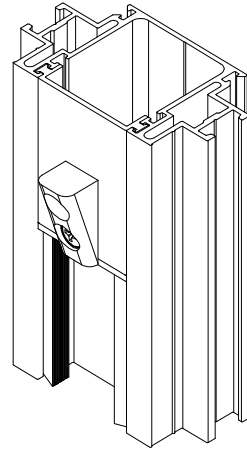
Image	Code	Article	Application
 <p>Leveling corner Pack quantity: 200 pcs</p>	10813600	AYPC.W62.0957	
 <p>Corner connector Master Pack quantity: 150 pcs</p>	10270400	MST0348	
 <p>Corner connector Monticelli Pack quantity: 250 pcs</p>	10270700	MON0406	
 <p>Corner connector Master Pack quantity: 150 pcs</p>	10270300	MST0311	

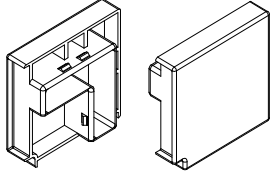
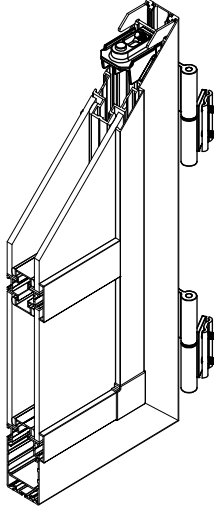
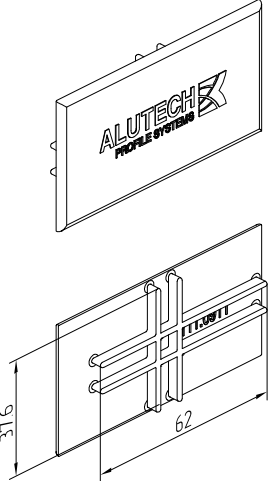
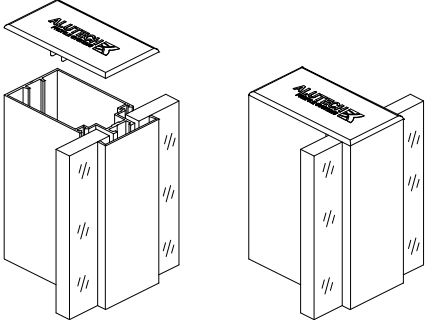
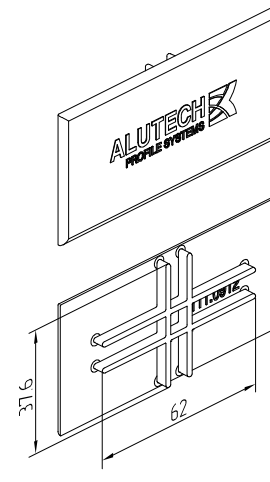
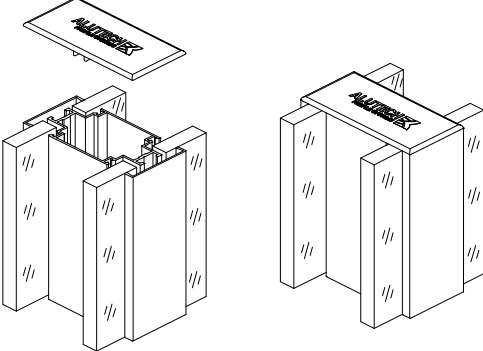

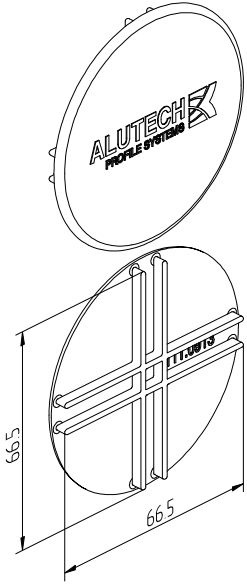
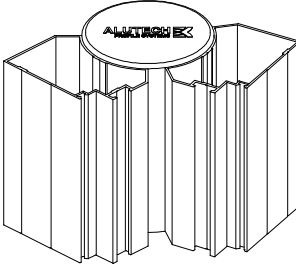
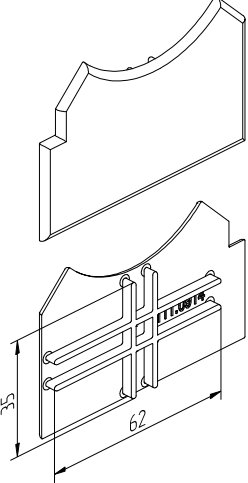
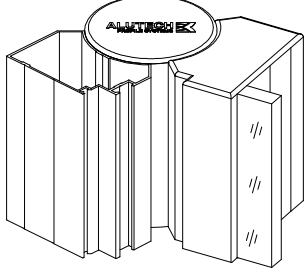
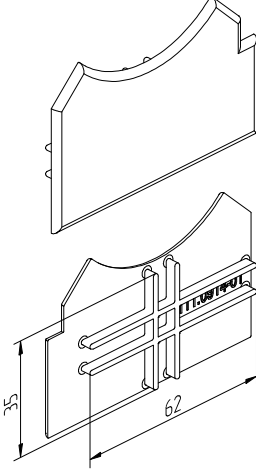
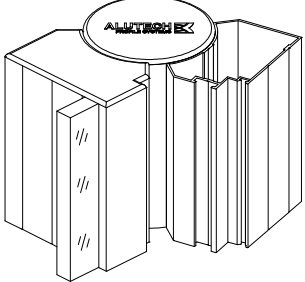
Image	Code	Article	Application
 <p>Corner connector Monticelli Pack quantity:: 250 pcs</p>	10270600	MON0373	
 <p>Corner connector Monticelli Pack quantity:: 250 pcs</p>	10513100	MON0436	
 <p>Fapim hinge Pack quantity:: 2 pcs</p>	10511831 (RAL9006)	AYPC.111.1001	
 <p>Hinge Pack quantity:: 2 pcs</p>	10511800 (00)		
	10511931 (RAL9006)		
	10511900 (00)		

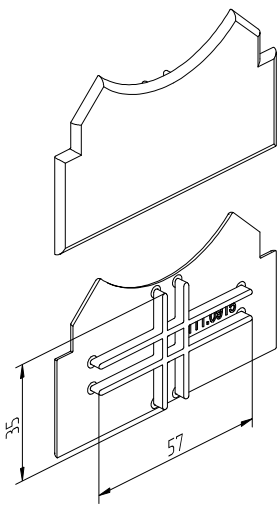
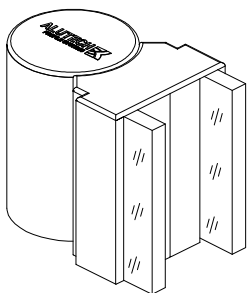
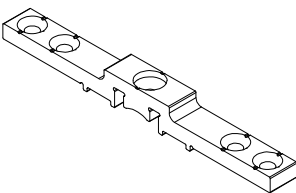
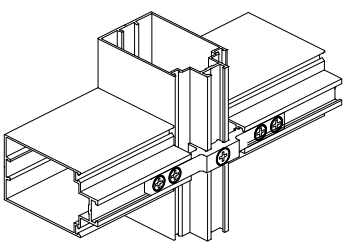
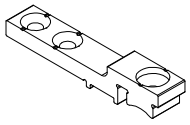
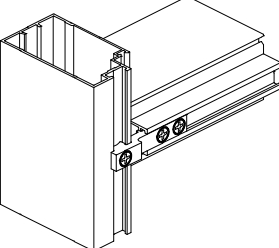
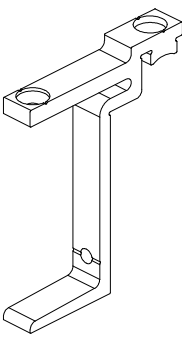
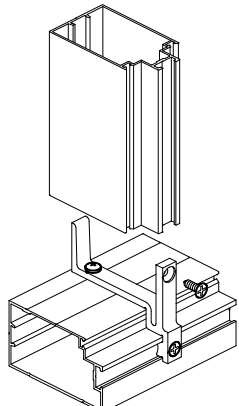
Image	Code	Article	Application
 <p>Hinge Pack quantity: 2 pcs</p>	10515231 (RAL9006)	AYPC.111.1006	
	10515200 (00)		
 <p>Hinge (colour: anodized, mill finish) Pack quantity: 2 pcs</p>	10515380	AYPC.111.1003M	
 <p>Lock (colour: A00-E6) (in kit with strike plate) Pack quantity: 1 pc</p>	10512280	AYPC.111.1004	

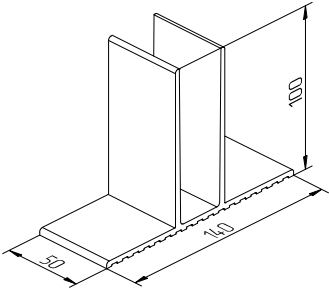
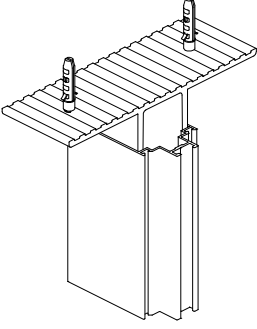
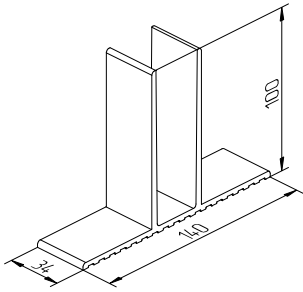
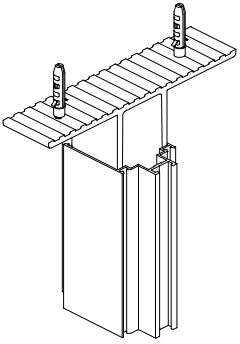
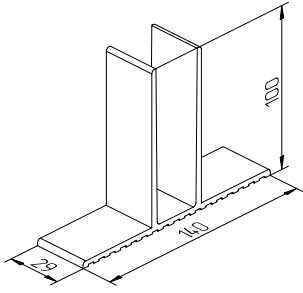
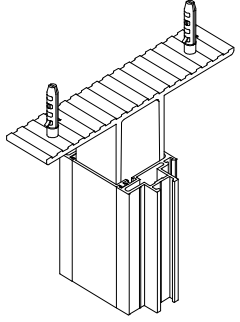
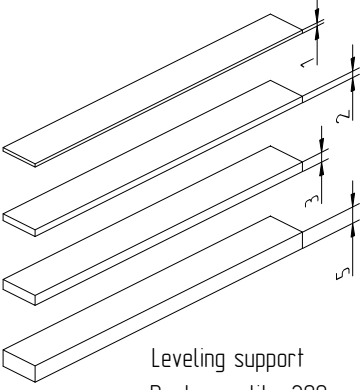
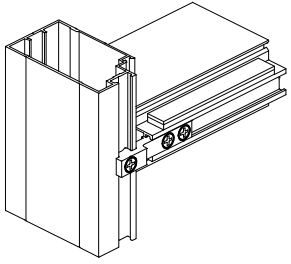
Image	Code	Article	Application
 <p>Face mounted latch Stublina 8 mm high, 225 mm length</p>	<p>13111331 (RAL9006)</p> <p>13111321 (RAL9016)</p> <p>13111330 (RAL8017)</p>	<p>3062.00</p>	
 <p>Strike plate Upper latch Stublina</p>	<p>13110500</p>	<p>3012.00</p>	
 <p>Strike plate Upper latch Stublina</p>	<p>13110700</p>	<p>3009.00</p>	
 <p>Bush Pack quantity: 500 pcs</p>	<p>13140500</p>	<p>06501</p>	

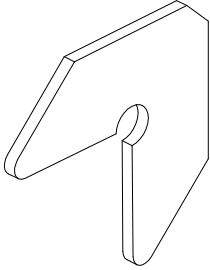
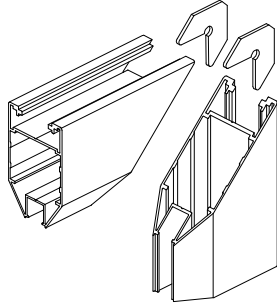
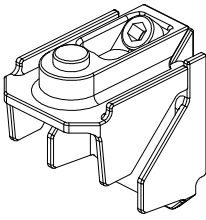
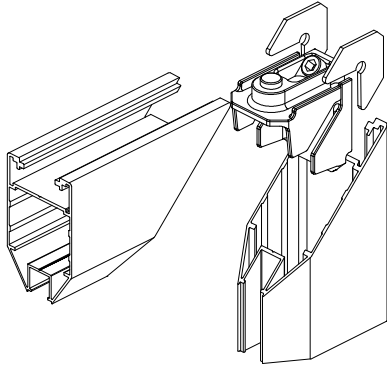
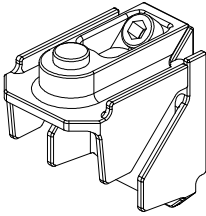
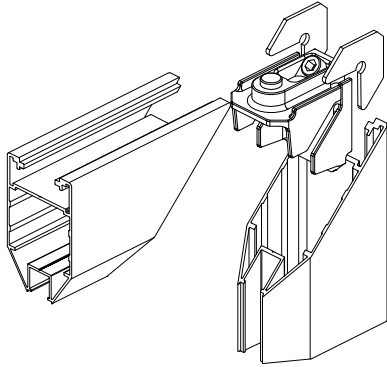
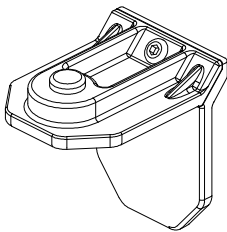
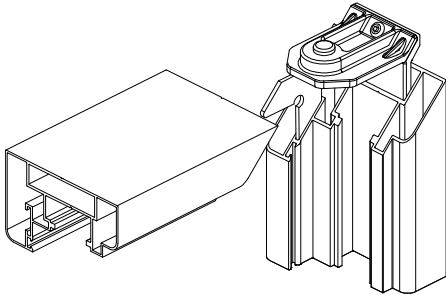
Image	Code	Article	Application
 <p>Strike plate Stublina for double leaf door</p>	10512631	3019.00.315	
 <p>Protective film</p>	10514600	15x45-3M	
<p>For corners: MST0311 MST0348</p>  <p>Jig Pack quantity: 1 pc</p>	10512400	AYPC.111.1100	
 <p>Jig Pack quantity: 1 pc</p>	10512500	AYPC.111.1101	

Image	Code	Article	Application
 <p>Bracket Pack quantity: 2 pcs</p>	10513600	AYPC.111.0750	
 <p>Roller kit Pack quantity: 1 kit</p>	10513800	R460	
 <p>Corner connector Pack quantity: 250 pcs</p>	10513900	04.19/250	
 <p>Handle kit Pack quantity: 5 kits</p>	10515031	111SL06 (RAL9006)	
	10516021	111SL16 (RAL9016)	
	105170806	111SLE6 (A00-E6)	

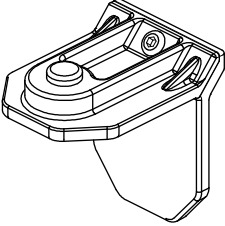
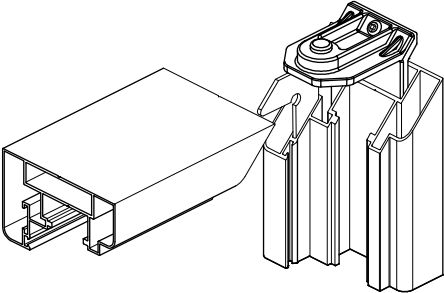
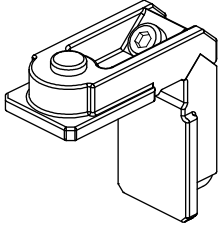
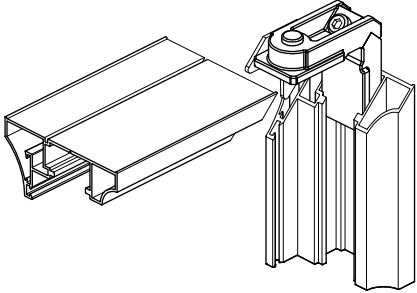
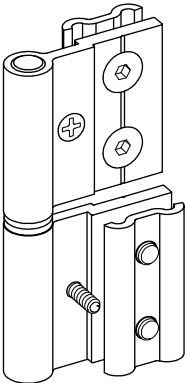
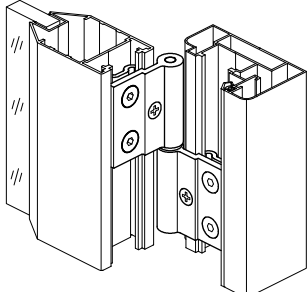
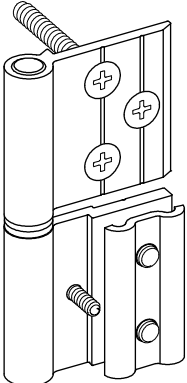
Image	Code	Article	Image	Code	Article
 <p>Lever handle Pack quantity: 20 pcs</p>	13110037 (RAL8017)	1032.00	 <p>Handle Pack quantity: 25 pcs</p>	13115637 (RAL8017)	1022.01
	13110032 (RAL9005)			13115632 (RAL9005)	
	13110031 (RAL9006)			13115631 (RAL9006)	
	13110021 (RAL9016)			13115621 (RAL9016)	
 <p>Cylinder covering plate Pack quantity: 20 pcs</p>	13110137 (RAL8017)	1031.02	 <p>Handle Pack quantity: 25 pcs</p>	13115537 (RAL8017)	1022.00
	13110132 (RAL9005)			13115532 (RAL9005)	
	13110131 (RAL9006)			13115531 (RAL9006)	
	13110121 (RAL9016)			13115521 (RAL9016)	
 <p>35/35 Knob cylinder Pack quantity: 50 pcs</p>	13116100	5109.00	 <p>Strike plate included into delivery kit Roller lock 24 mm Pack quantity: 25 pcs</p>	13111700	3031.24
 <p>35/35 cylinder Pack quantity: 72 pcs</p>	13112200	5063.00	 <p>Strike plate included into delivery kit Lever lock 24 mm Pack quantity: 25 pcs</p>	13111600	3021.24

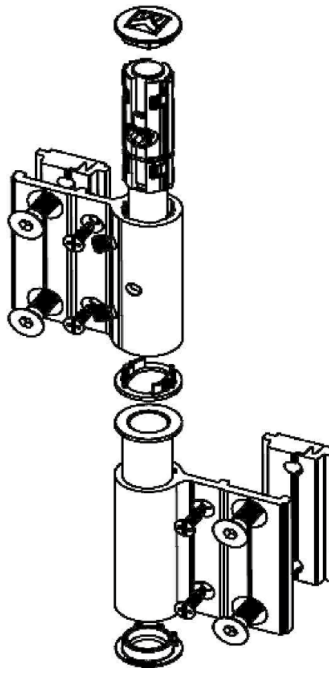
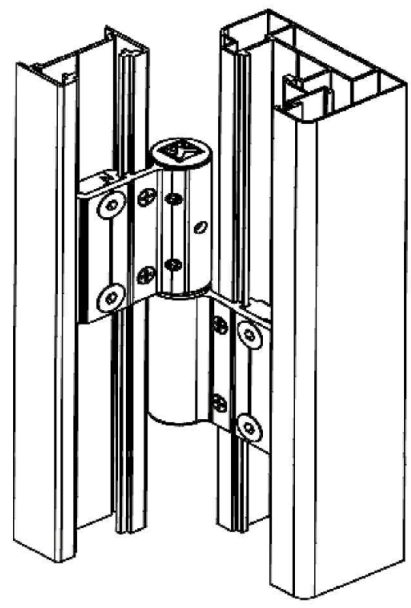
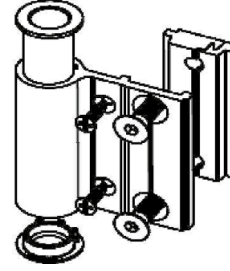
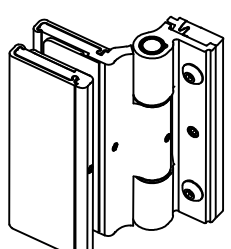
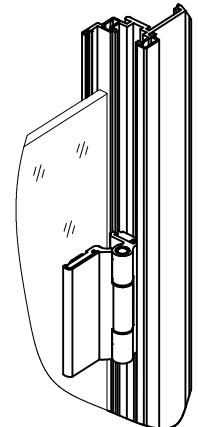
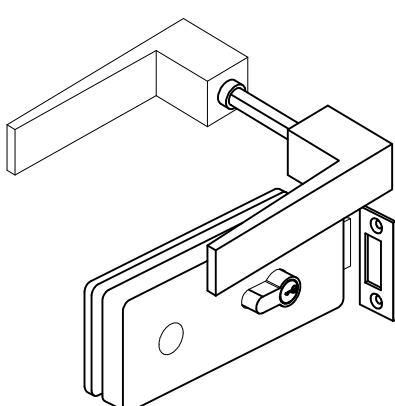
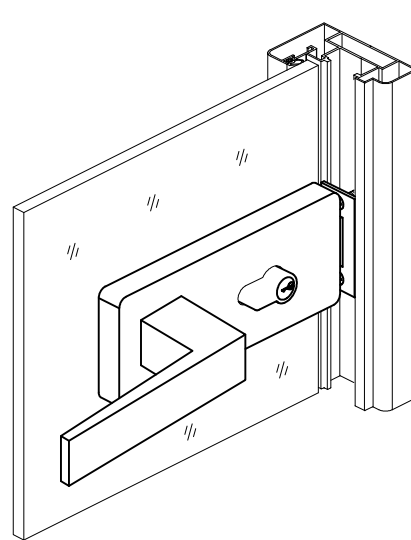
Image	Code	Article	Application
 <p>Corner connector Pack quantity: 250 pcs</p>	10513500	0477/250	
 <p>Screws M5x35 DIN7991 – 8 pcs, for leaf profile connection, not included into the kit.</p> <p>Hinge kit Pack quantity: 1 kit</p>	105151806	AYPC.111.1005	
 <p>Adapter Pack quantity: 1 kit (2 pcs)</p>	105144806	A764	
 <p>Lock with handle Pack quantity: 1 kit</p>	105143806	A1530K/K	

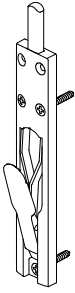
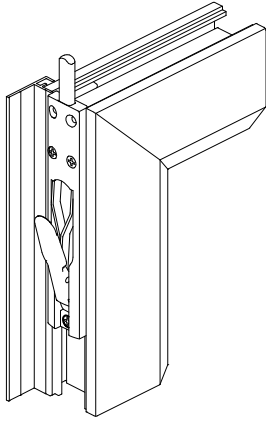
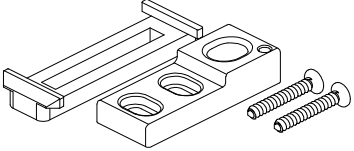
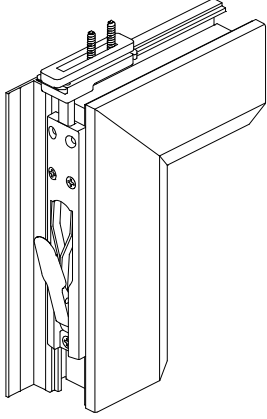
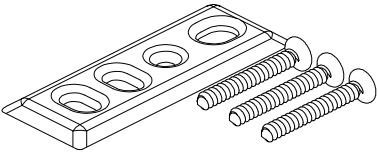
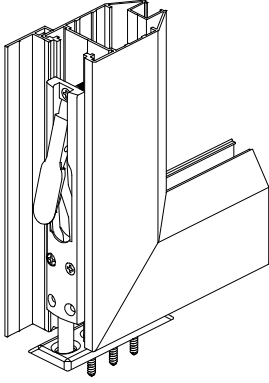
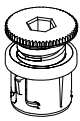
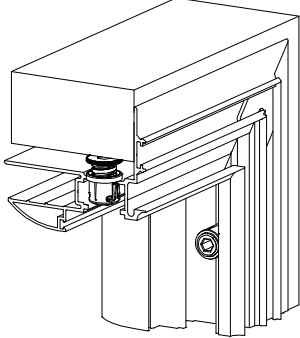

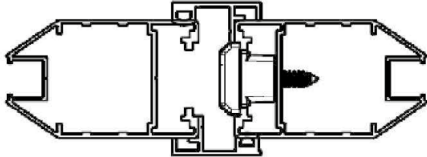
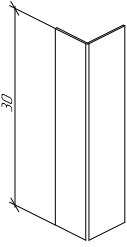
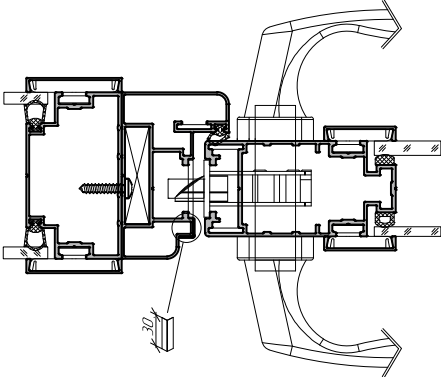
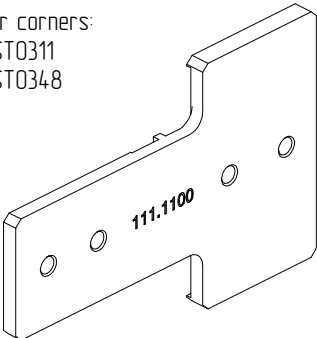
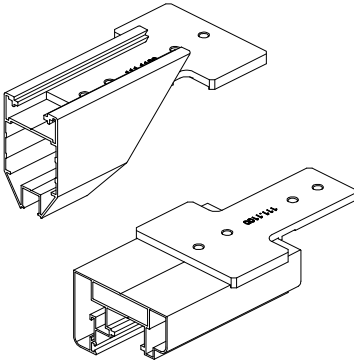
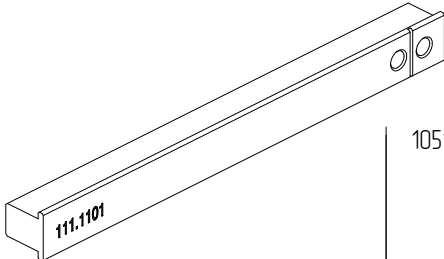
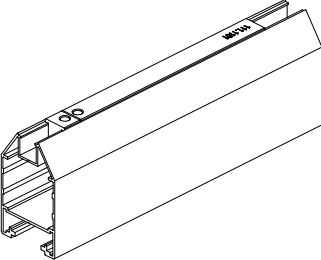

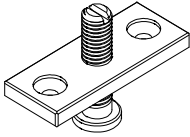
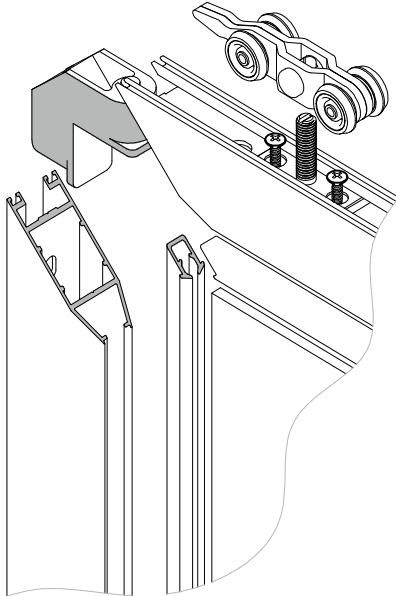
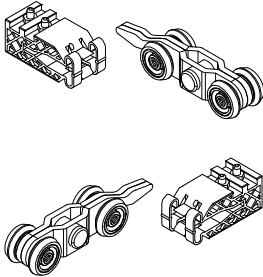
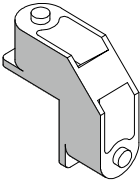
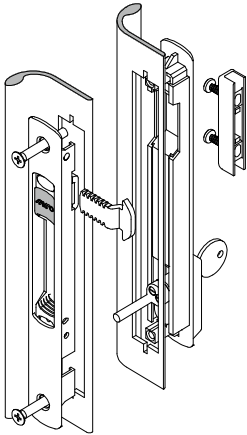
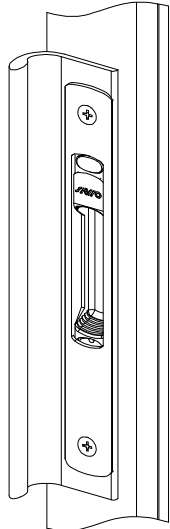

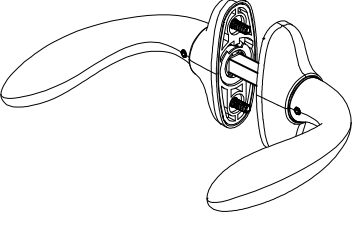
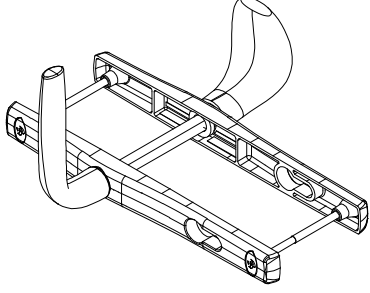
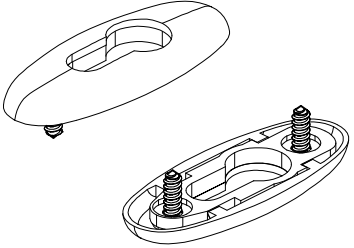
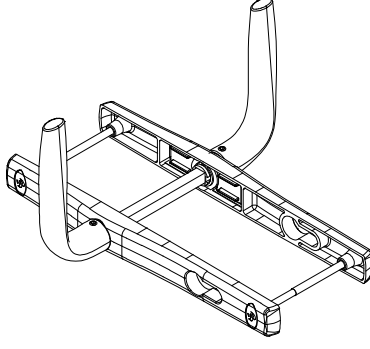
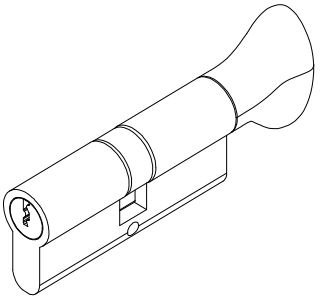
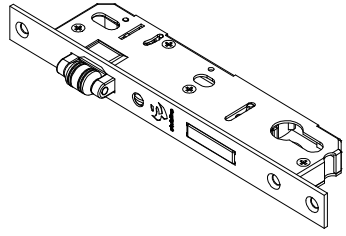
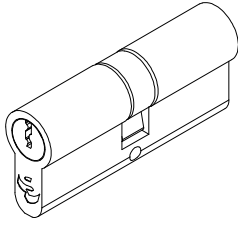
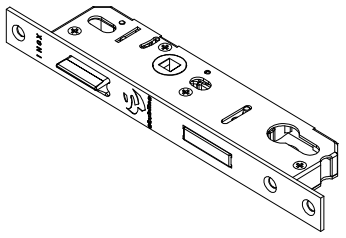
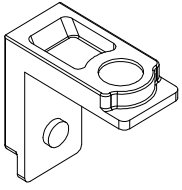
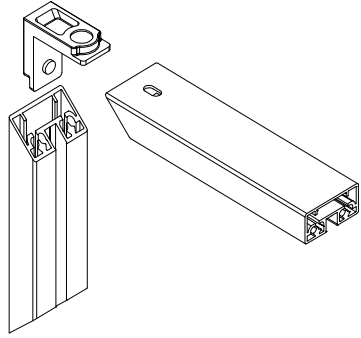
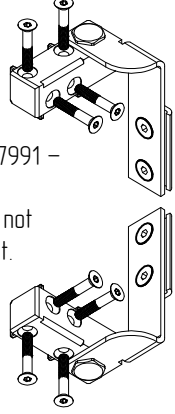
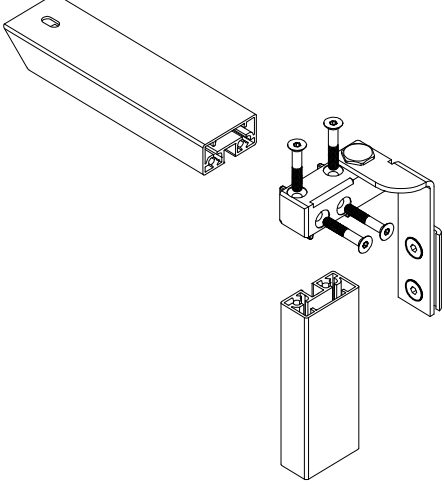
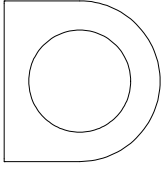
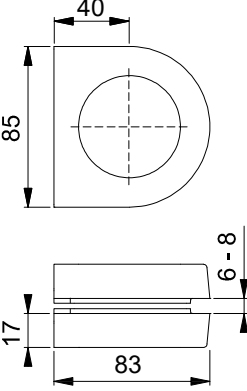
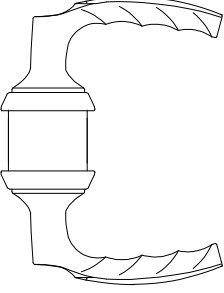
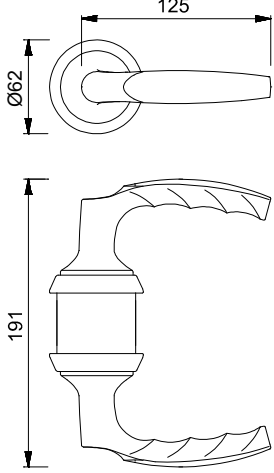
**ALUTECH ALT 111**  
Interior partition system

# Gaskets

01

02

03

04

**05**

06

07

08

09

10

11

12

13



14

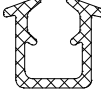

Article	Code		Image	Weight, kg/m	Material	Qty in pack, m	Description
FRK02	black	10210200		-	EPDM	200	For partition with 10 mm infill unit
	grey	10210265			TPE	400	
FRK07	black	10210600		-	EPDM	200	Ledge gasket for aluminium or wooden door
	grey	10210665			TPE	300	
FRK34	black	10212800		-	EPDM	200	For 4 mm glass in single glazed door
	grey	10212865			TPE	150	
FRK35	black	10212900		-	EPDM	200	For 5 and 6 mm glass in single glazed door
	grey	10212965			TPE	200	
FRK57	black	10511300		-	TPE	400	For partition with 4 and 5 mm glass
	grey	10511365			EPDM	400	
FRK58	black	10511400		-	TPE	400	For partition with 6 mm glass
	grey	10511465			EPDM	400	
FRK59	black	10511500		-	TPE	300	For partition with 8 mm glass
	grey	10511565			EPDM	300	
FRK60	grey	10511665		-	EPDM	350	For 4 and 5 mm glass in double glazed door
FRK61	grey	10511765		-	EPDM	350	For 6 mm glass in double glazed door
FRK95	black	10512300		-	TPE	200	Door ledge gasket
	grey	10512365					
FRK104	black	10513700		-	EPDM	100	Ledge gasket for sliding door
	grey	10513765			EPDM	100	
FRK135	-	10513300		-	silicone	200	For 6 mm glass into the leaf made from AYPC.111.0117 profile



ATTENTION! The gaskets are coated with silicone grease. Avoid contact of the gasket and visible parts of the glass when working with sandblasted glass.

Article	Code		Image	Weight, kg/m	Material	Qty in pack, m	Description
PB04.8.0750-FP	grey	10211300		-	combined	1000	Shlegel brush seal for door bottom
SK10.134BLK	grey	10413800		-	combined	1000	Shlegel brush seal for door bottom
47x50	grey	10514900		-	combined	500	Felt seal for sliding door aperture



**ALUTECH ALT 111**  
Interior partition system

## Glass installation

01

02

03

04

05

**06**

07

08

09

10

11

12

13

14



Partition

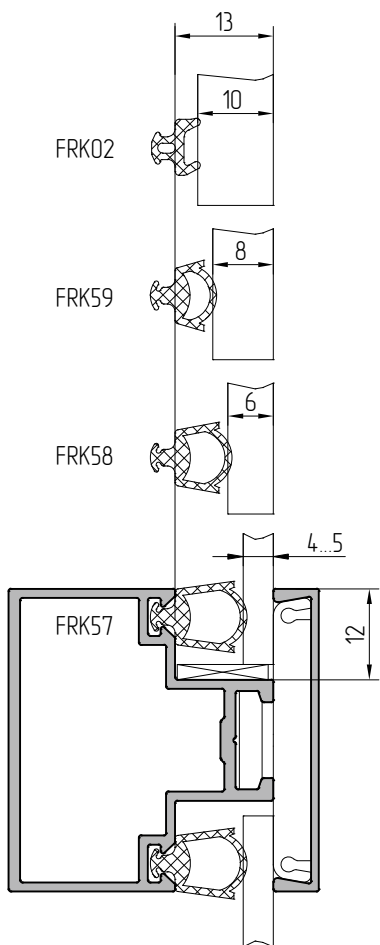

Door with double glazing

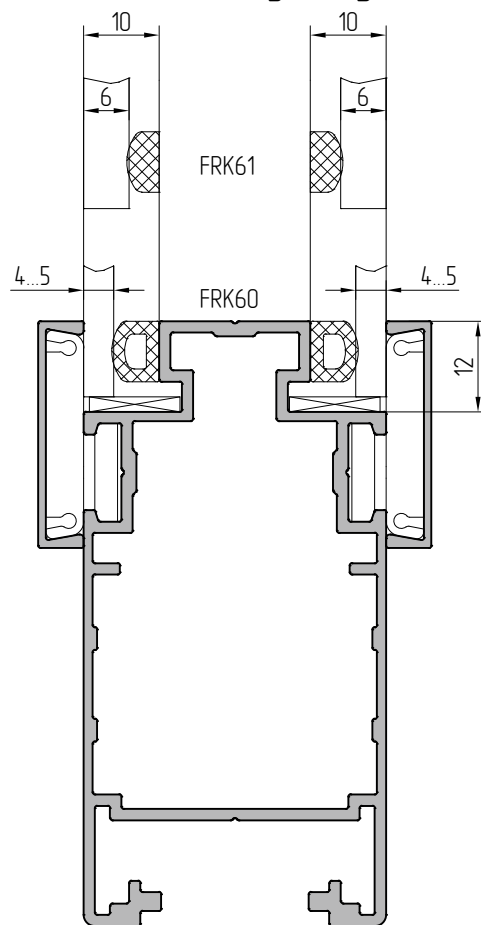

Door with single glazing

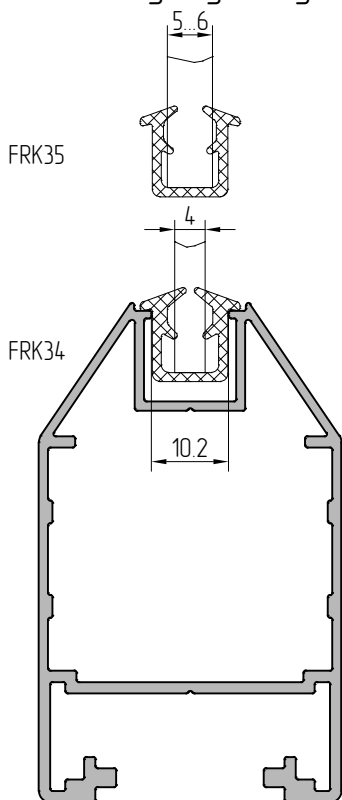

Partition with sliding door

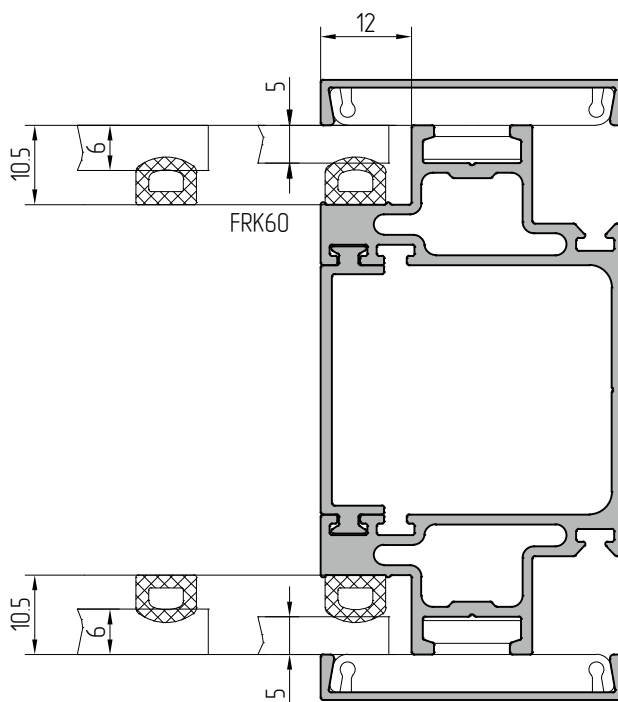







**ALUTECH ALT 111**  
Interior partition system

## Glass supports installation

01

02

03

04

05

06

**07**

08

09

10

11

12

13

14



Partition

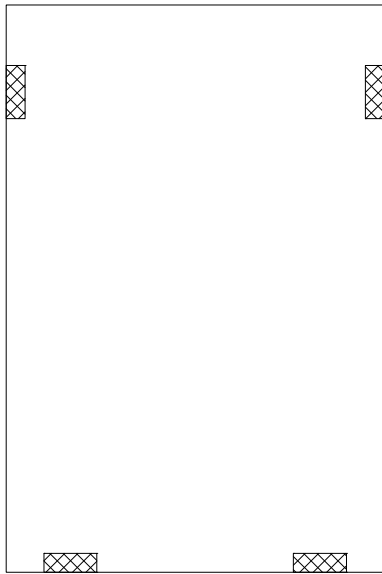

Swing door with double glazing

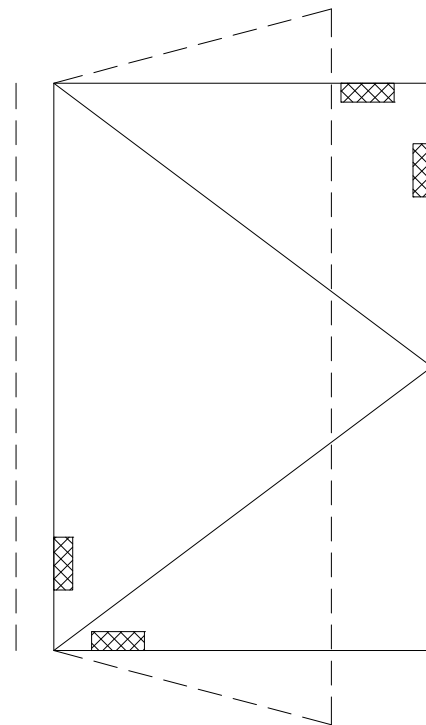

Swing door with double glazing and transom

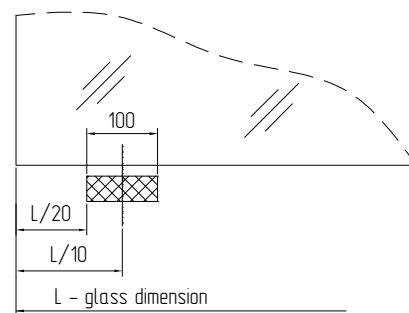
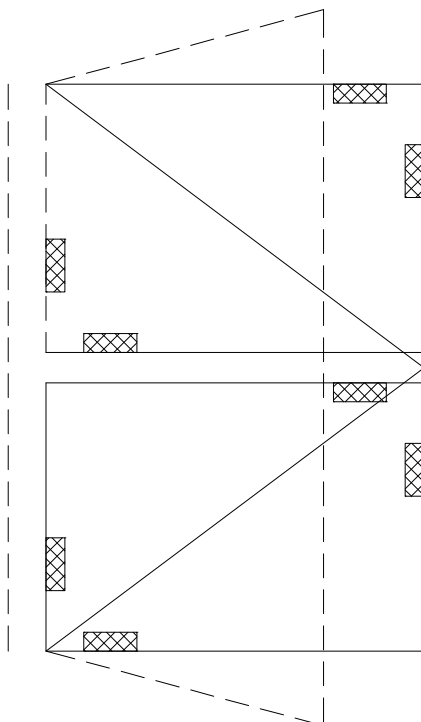





**ALUTECH ALT 111**  
Interior partition system

## Partition frames assemblage

01

02

03

04

05

06

07

**08**

09

10

11

12

13

14



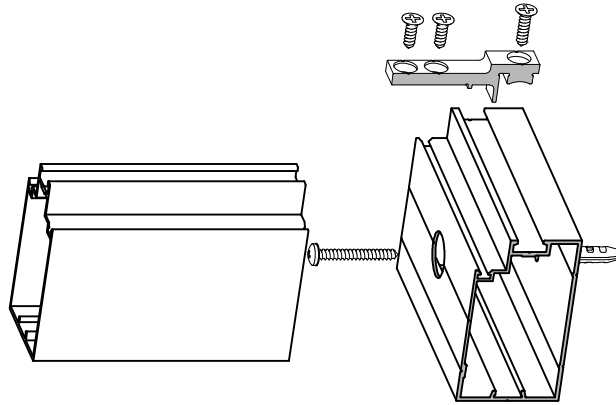
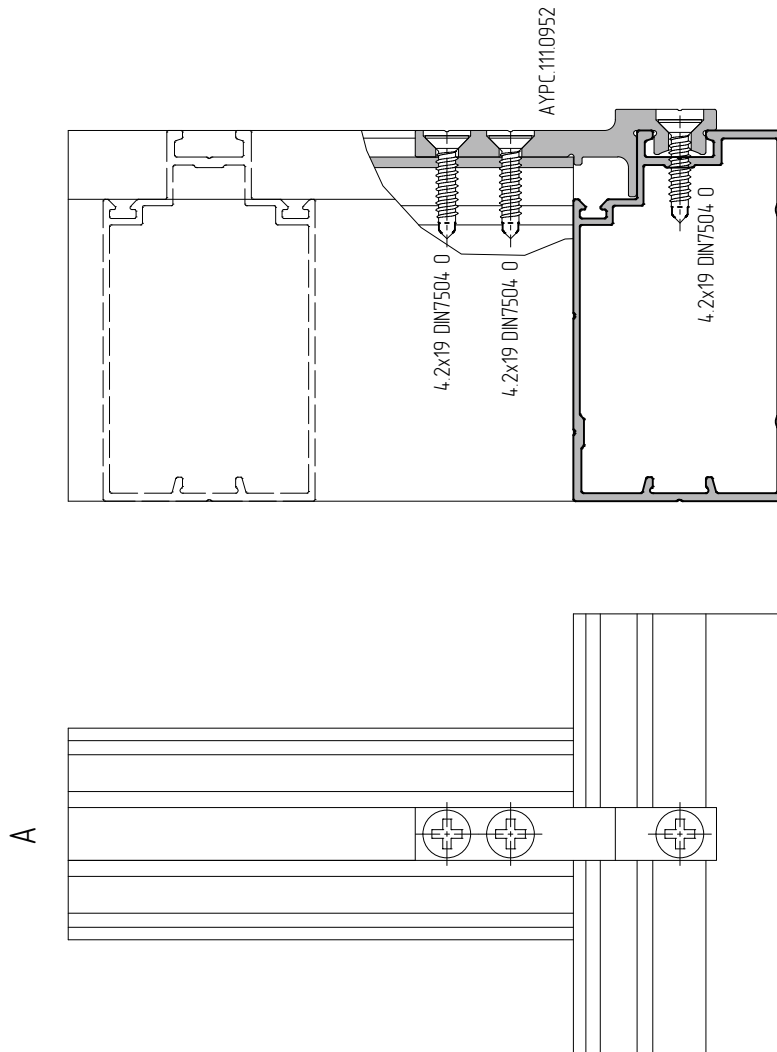
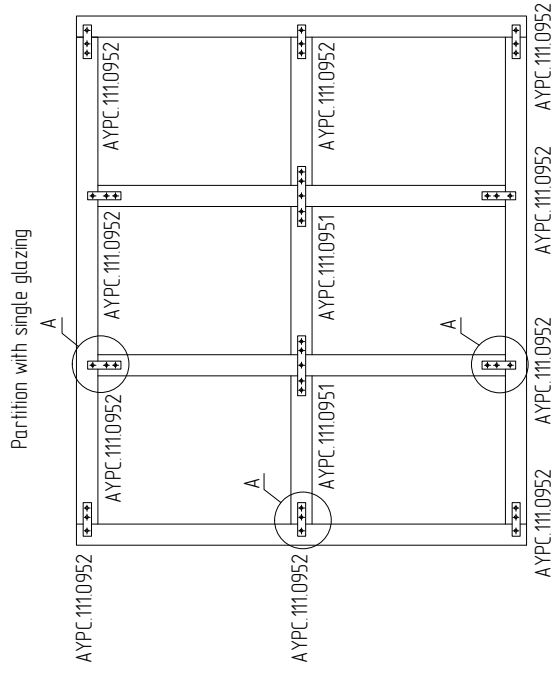

 Attention  
No AYPC.111.0903 plugs  
are required in the  
multion-transom junction.

Partition with single glazing, inclined transom

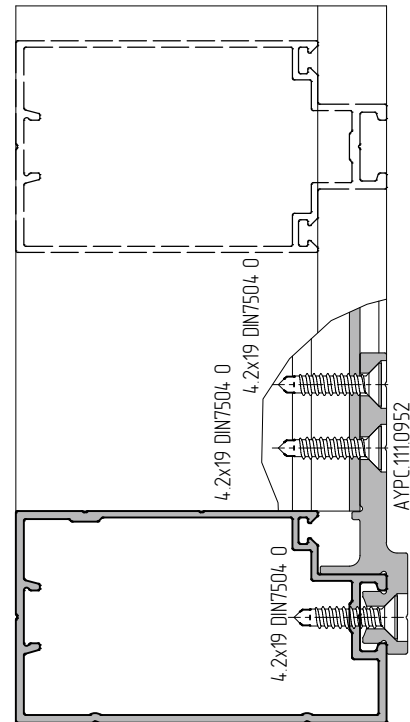
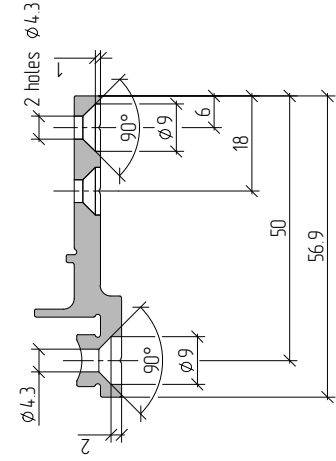
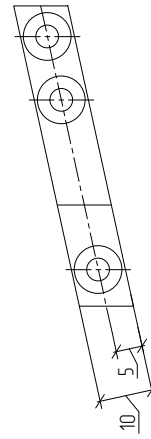
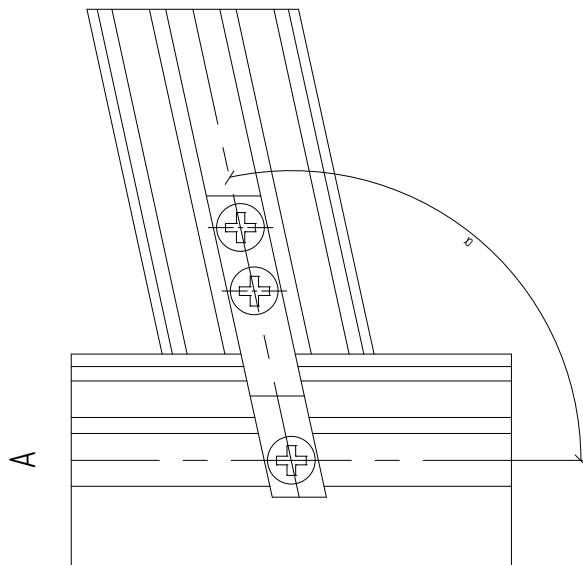
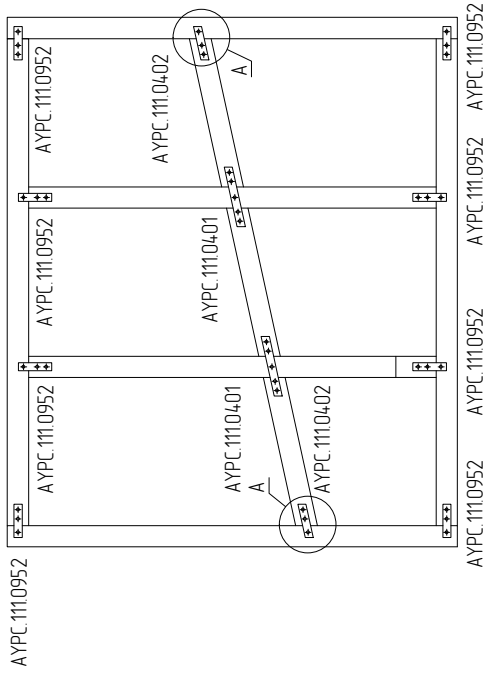



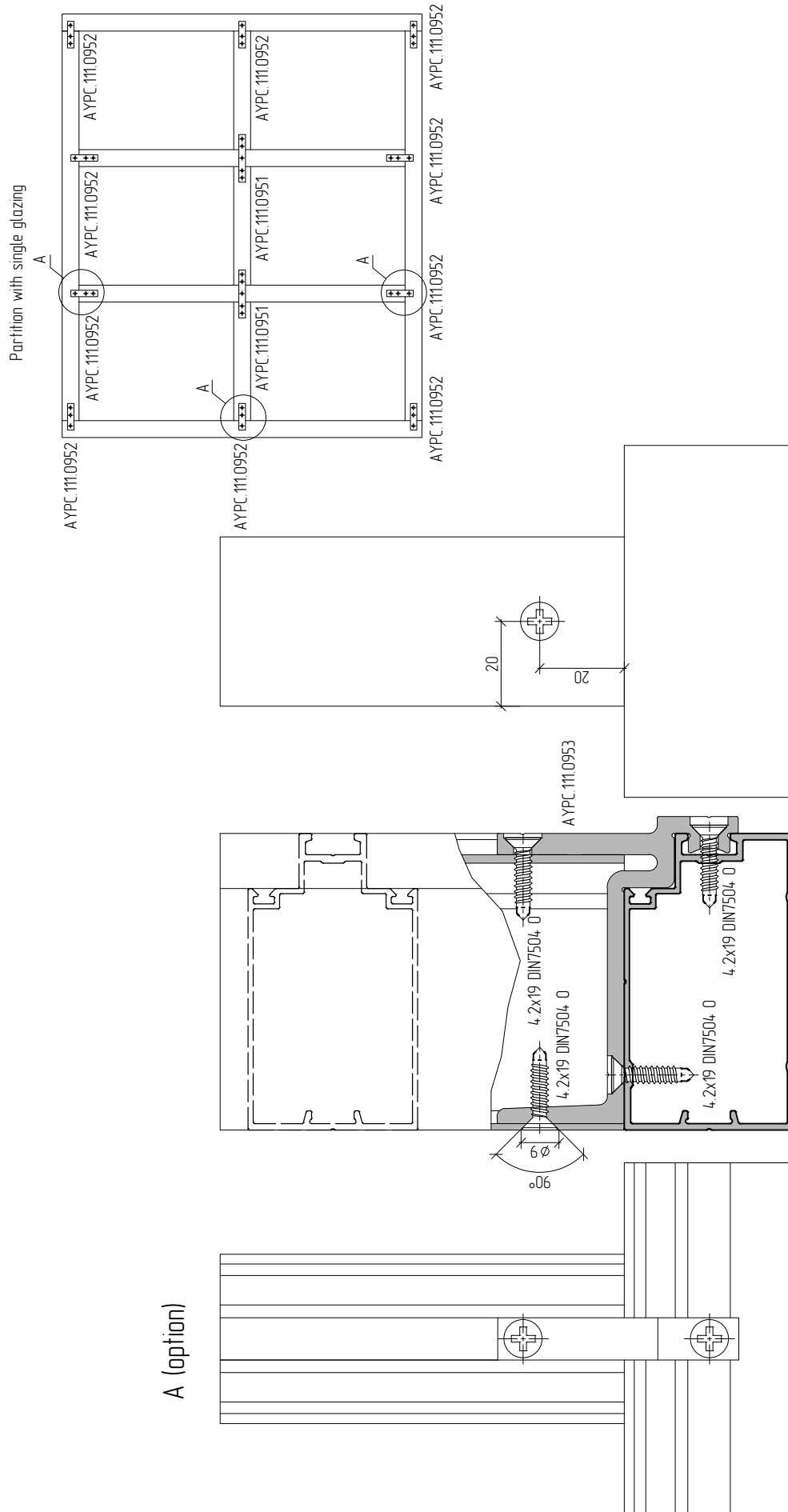

Partition with single glazing

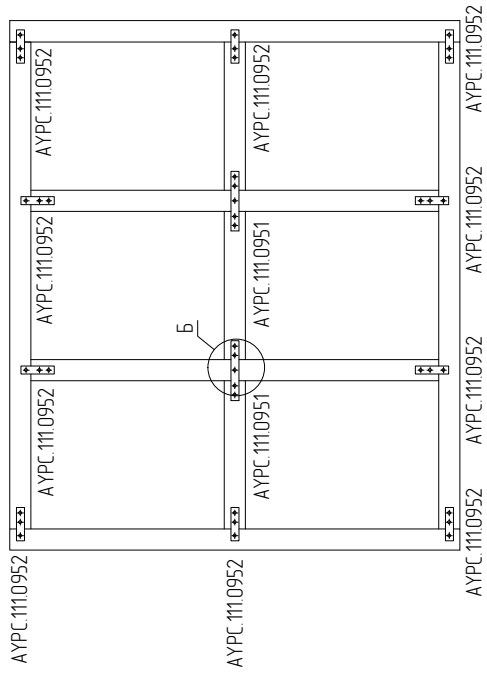

b

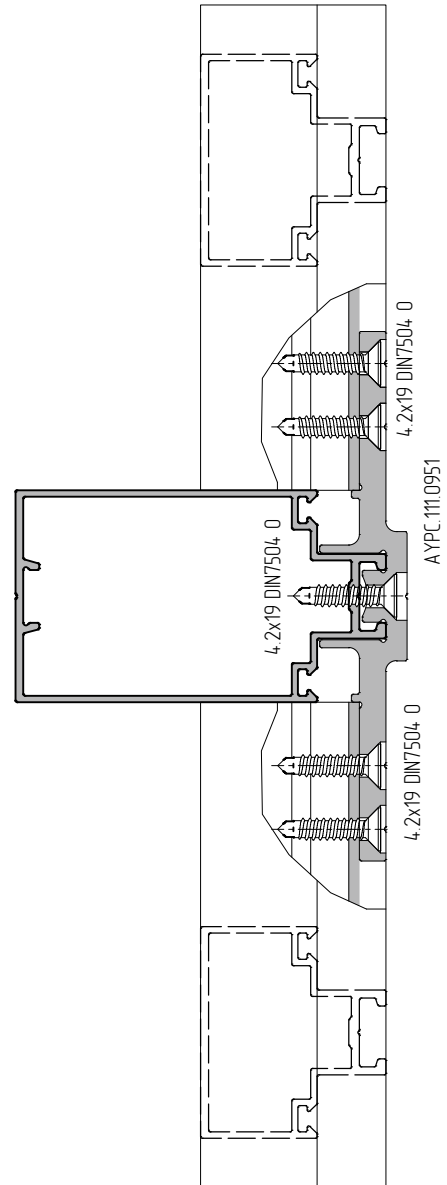
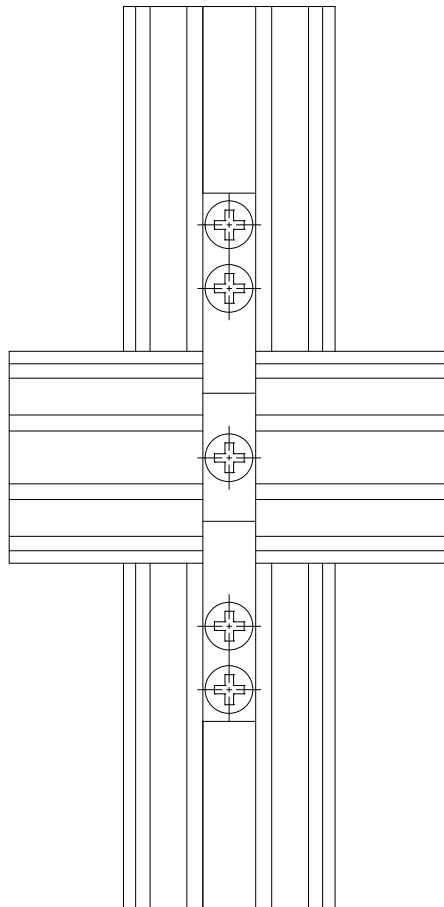

Partition with single glazing, inclined transom

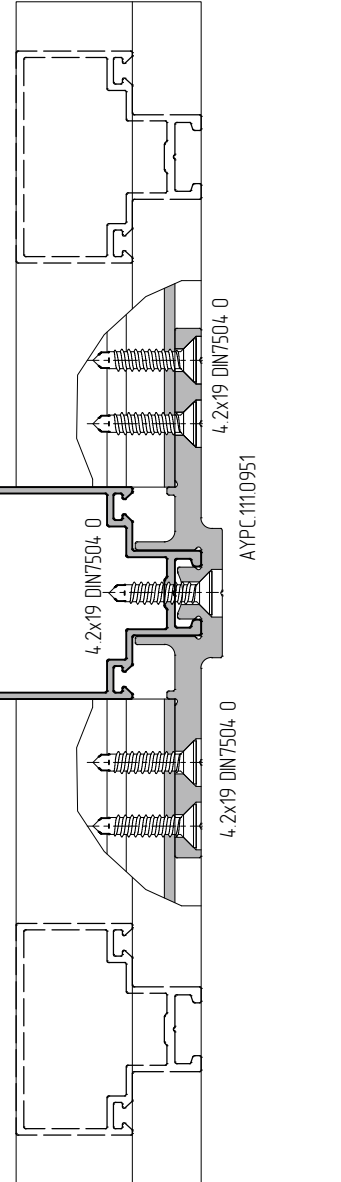
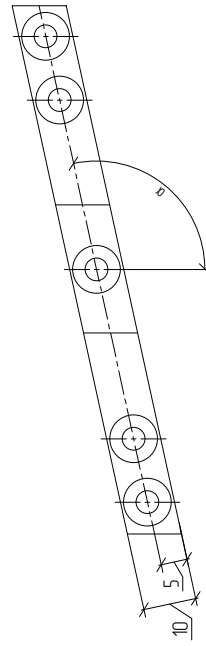
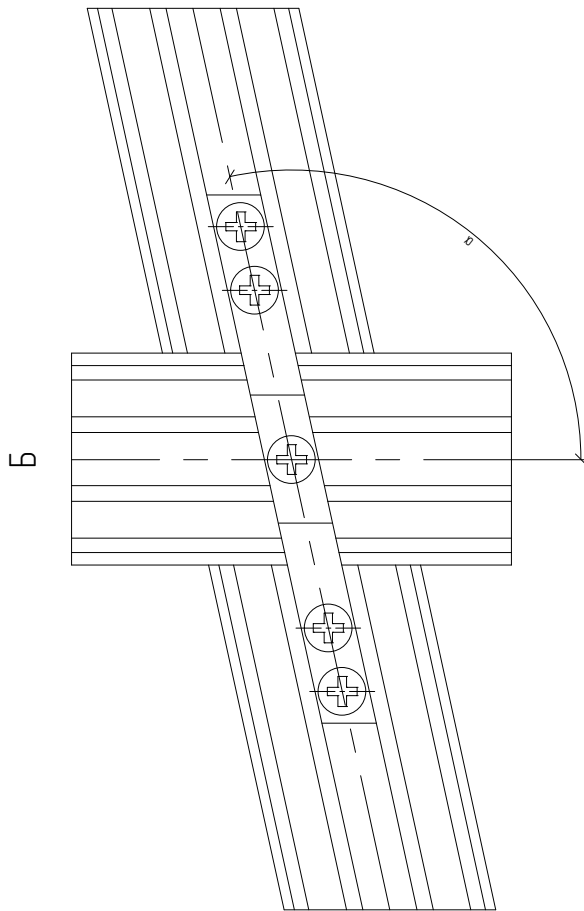
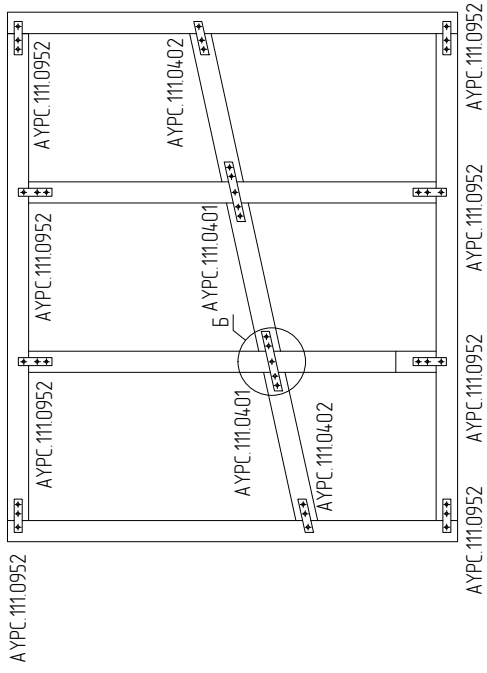

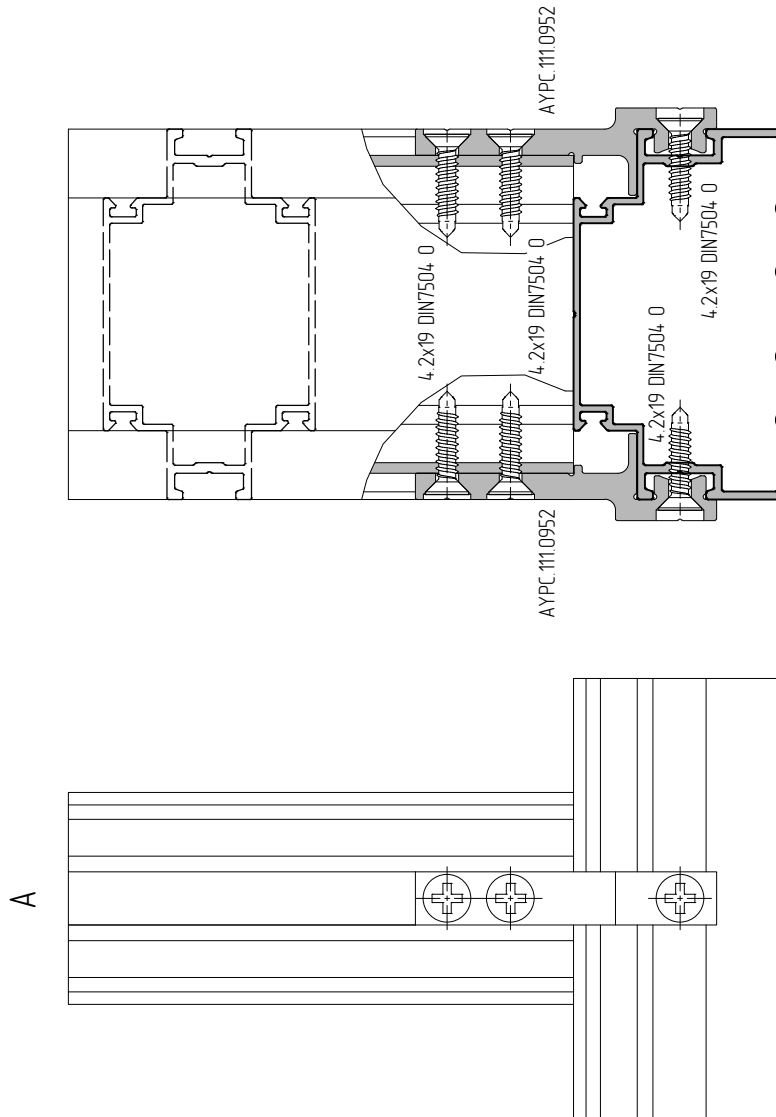
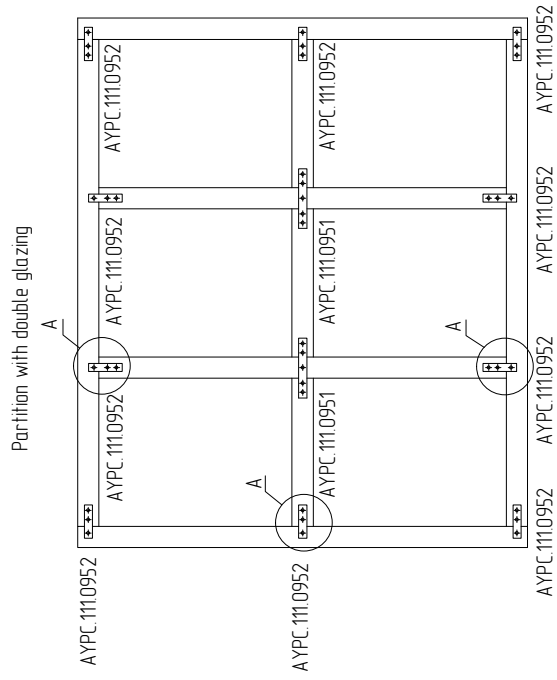

Partition with single glazing, inclined transom

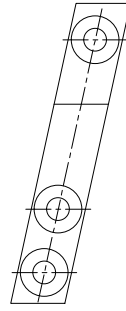
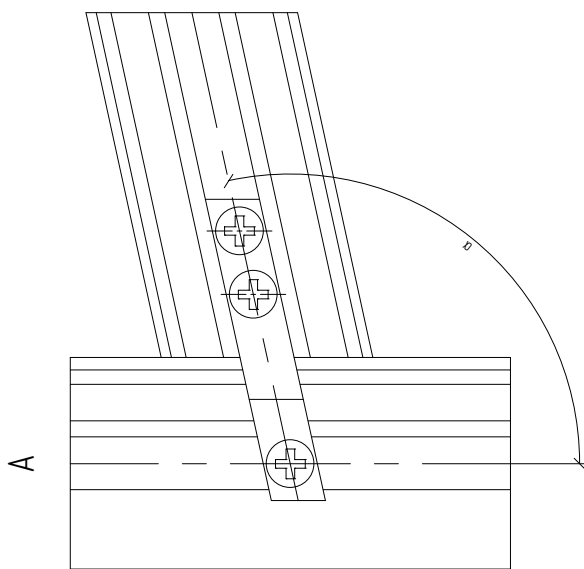
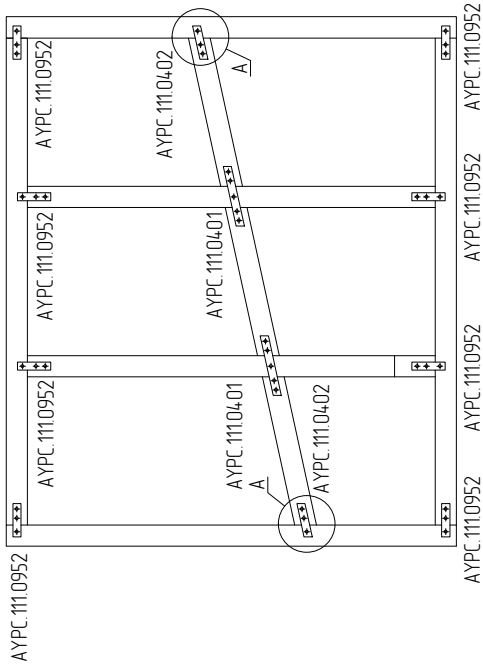

Attention!  
The second bracket is mounted  
in inversed manner to the first

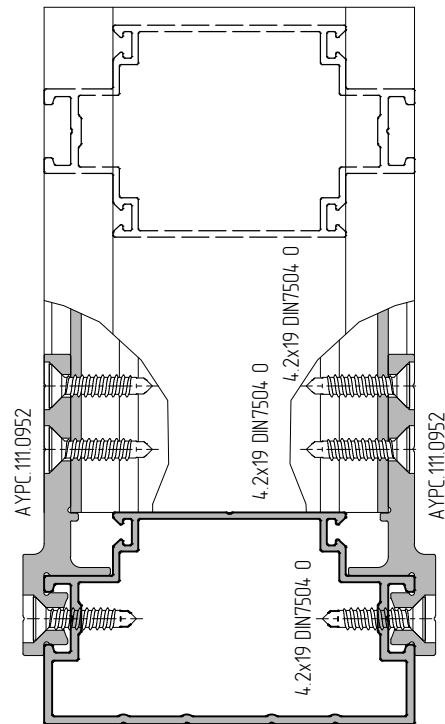
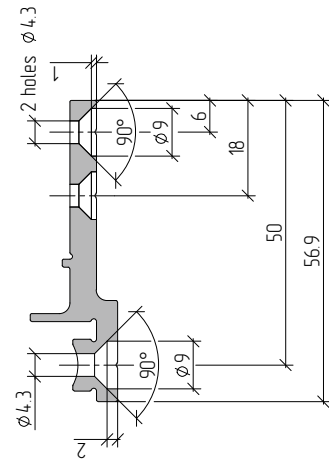
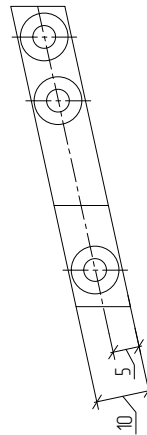

Partition with double glazing

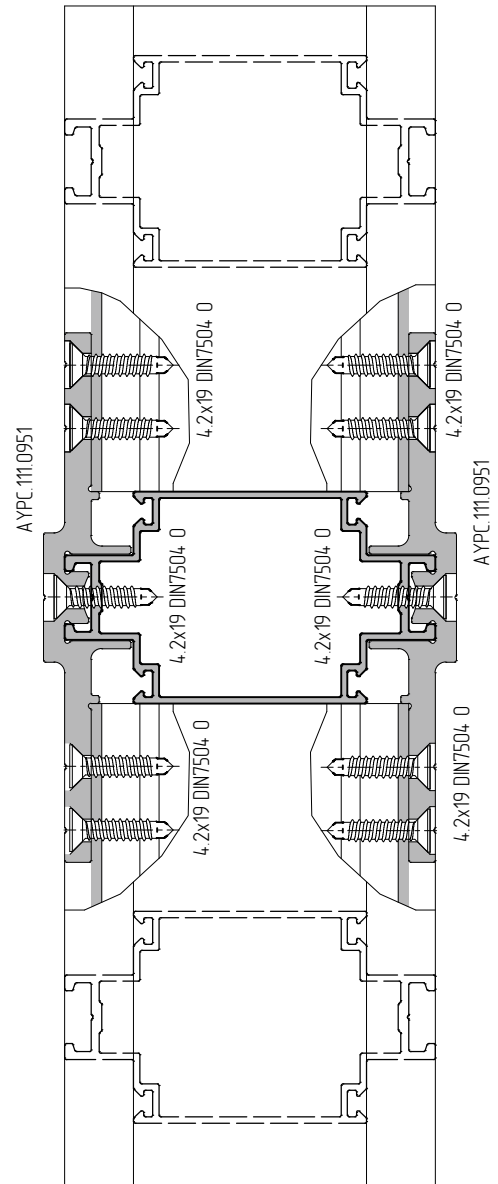
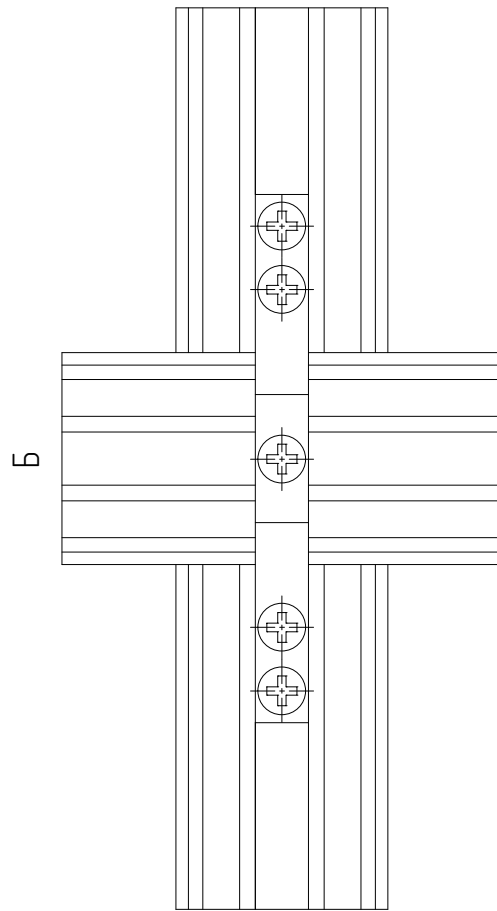
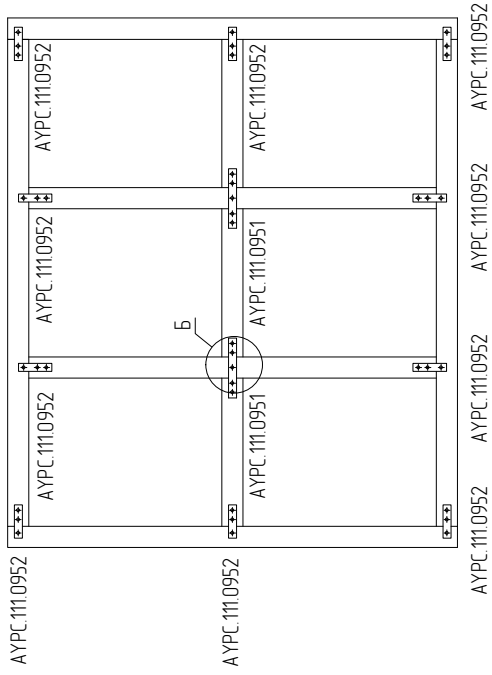

Partition with single glazing, inclined transom

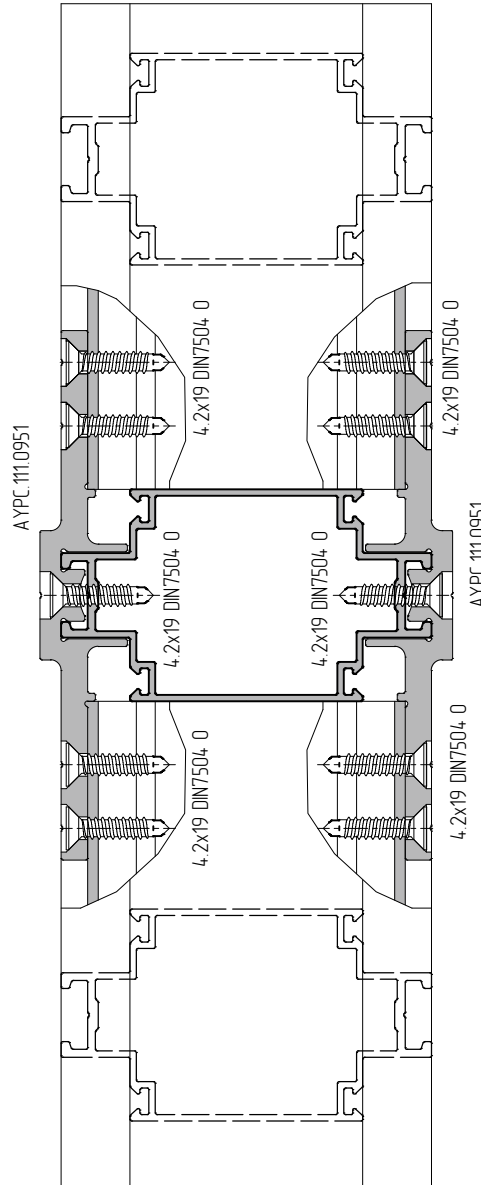
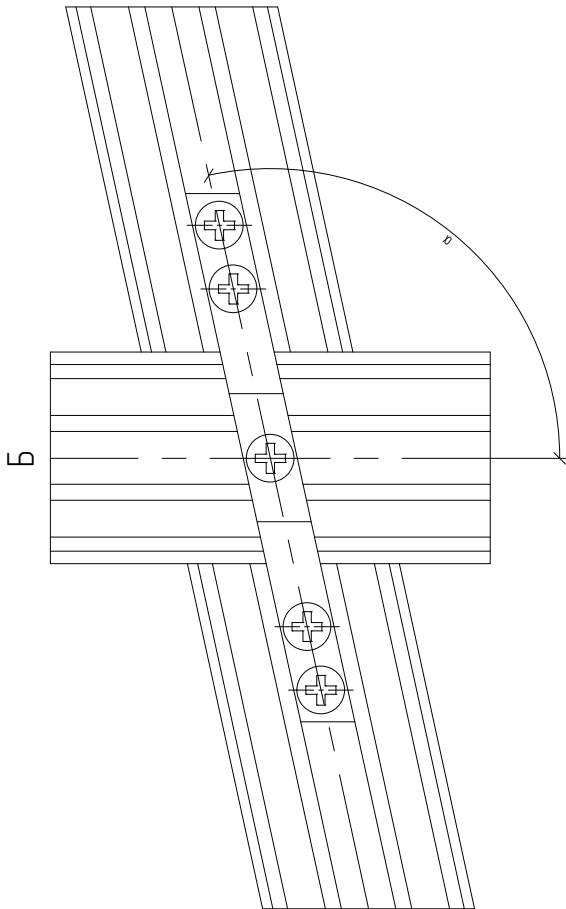
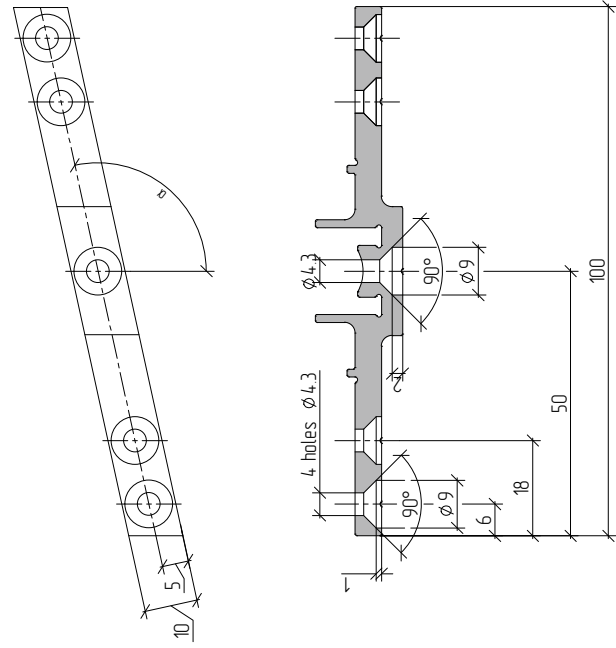
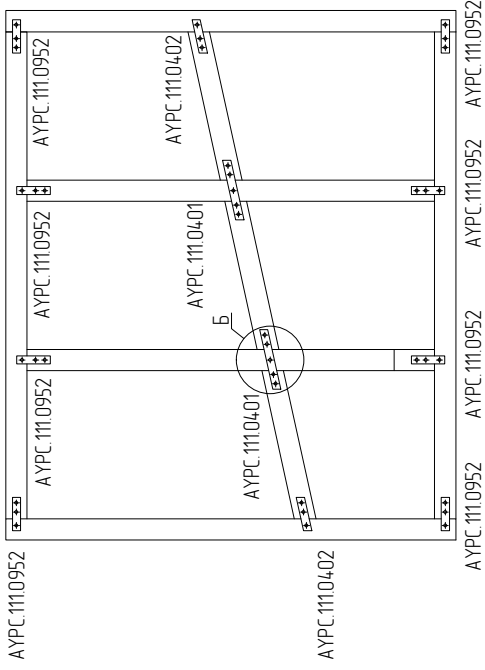

Attention!  
The second bracket is mounted  
in inversed manner to the first.

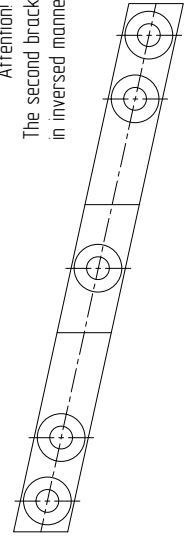

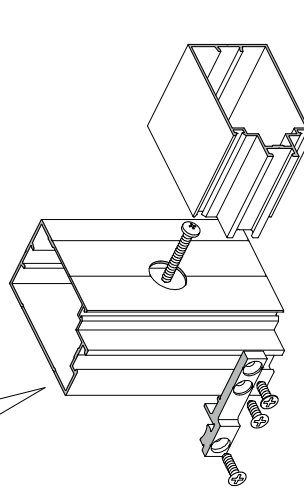
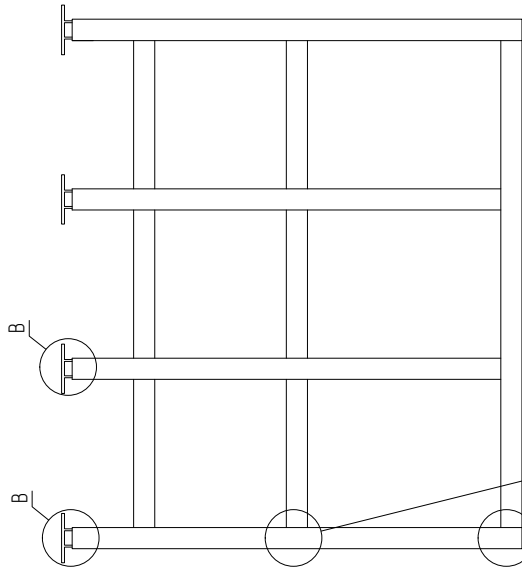

If the mullion-wall and mullion-transom junctions coincide, no need for AYPC.111.0903 plug installation.

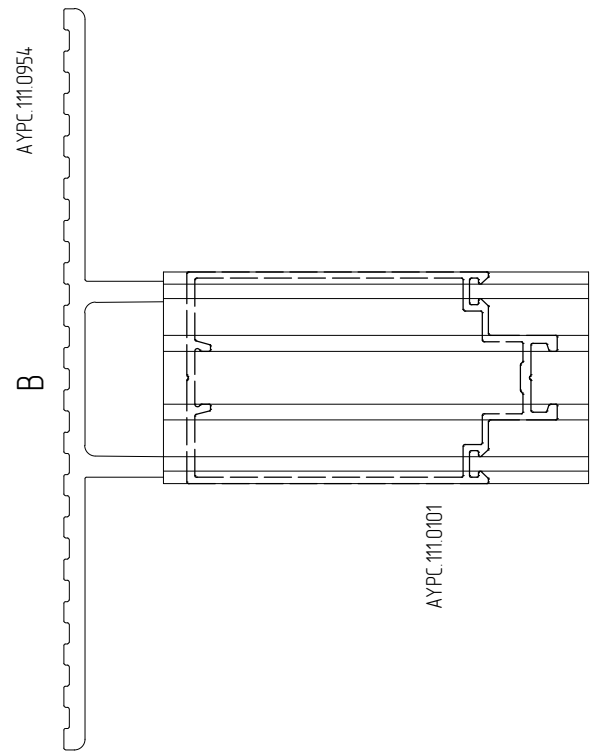
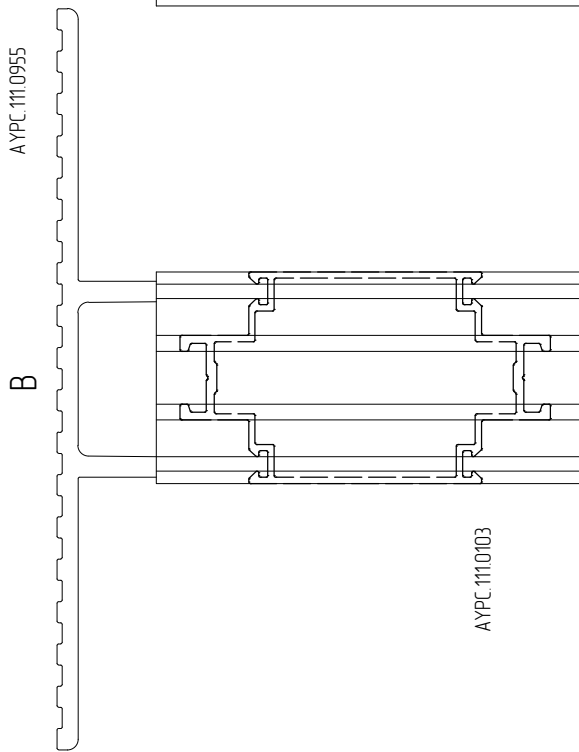
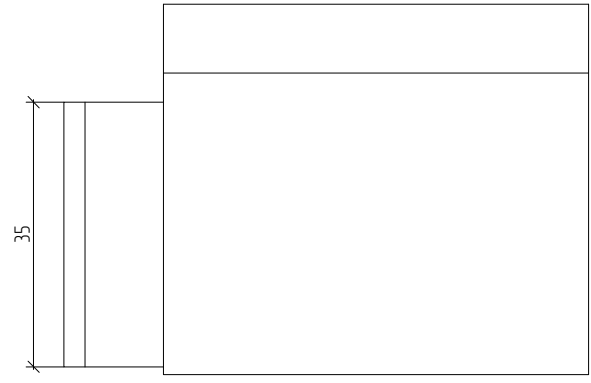
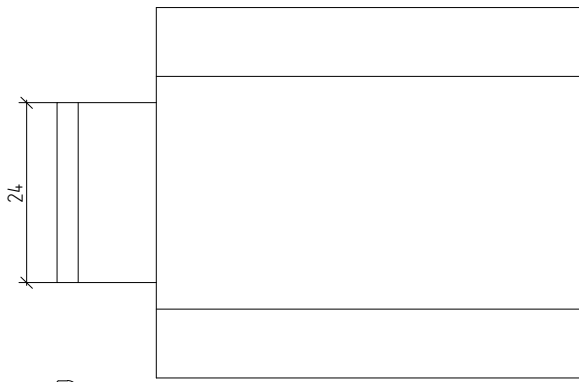





**ALUTECH ALT 111**  
Interior partition system

## Partition sections

01

02

03

04

05

06

07

08

**09**

10

11

12

13

14



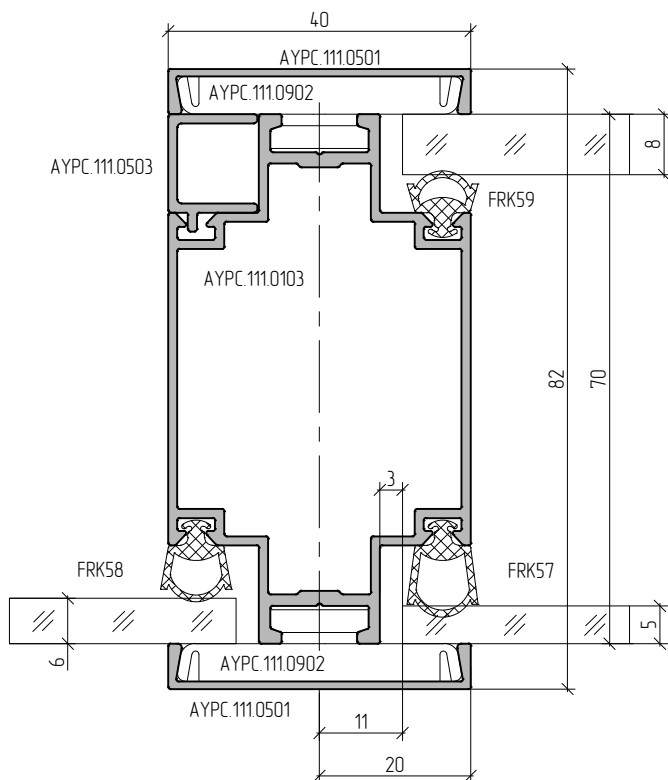
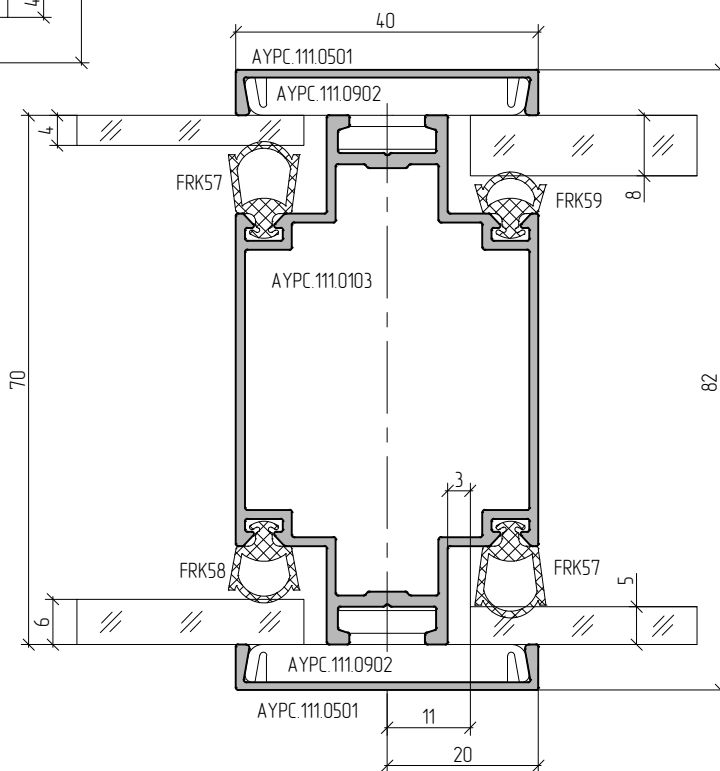
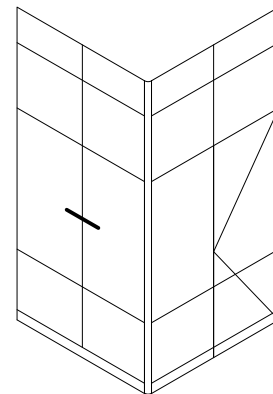
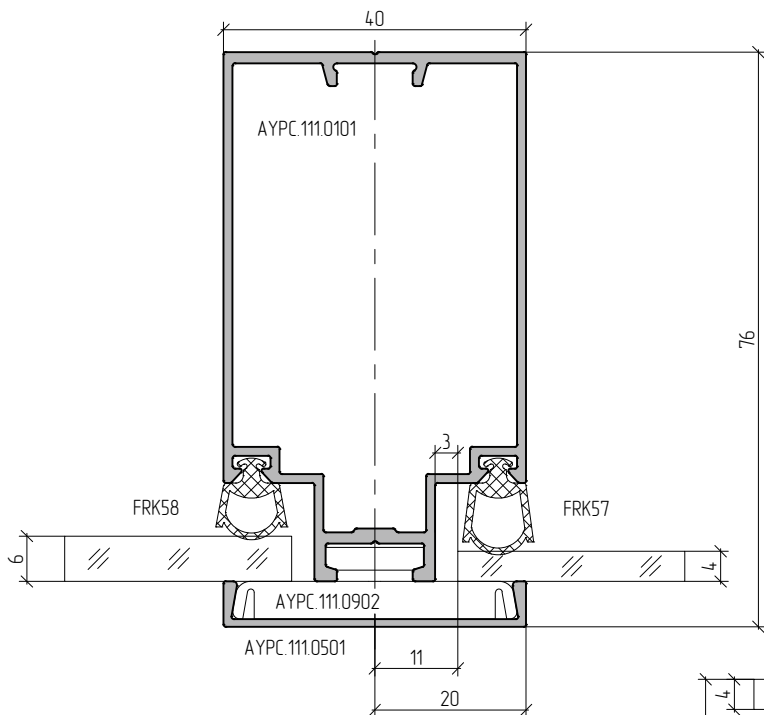

Transition from double glazing to single glazing

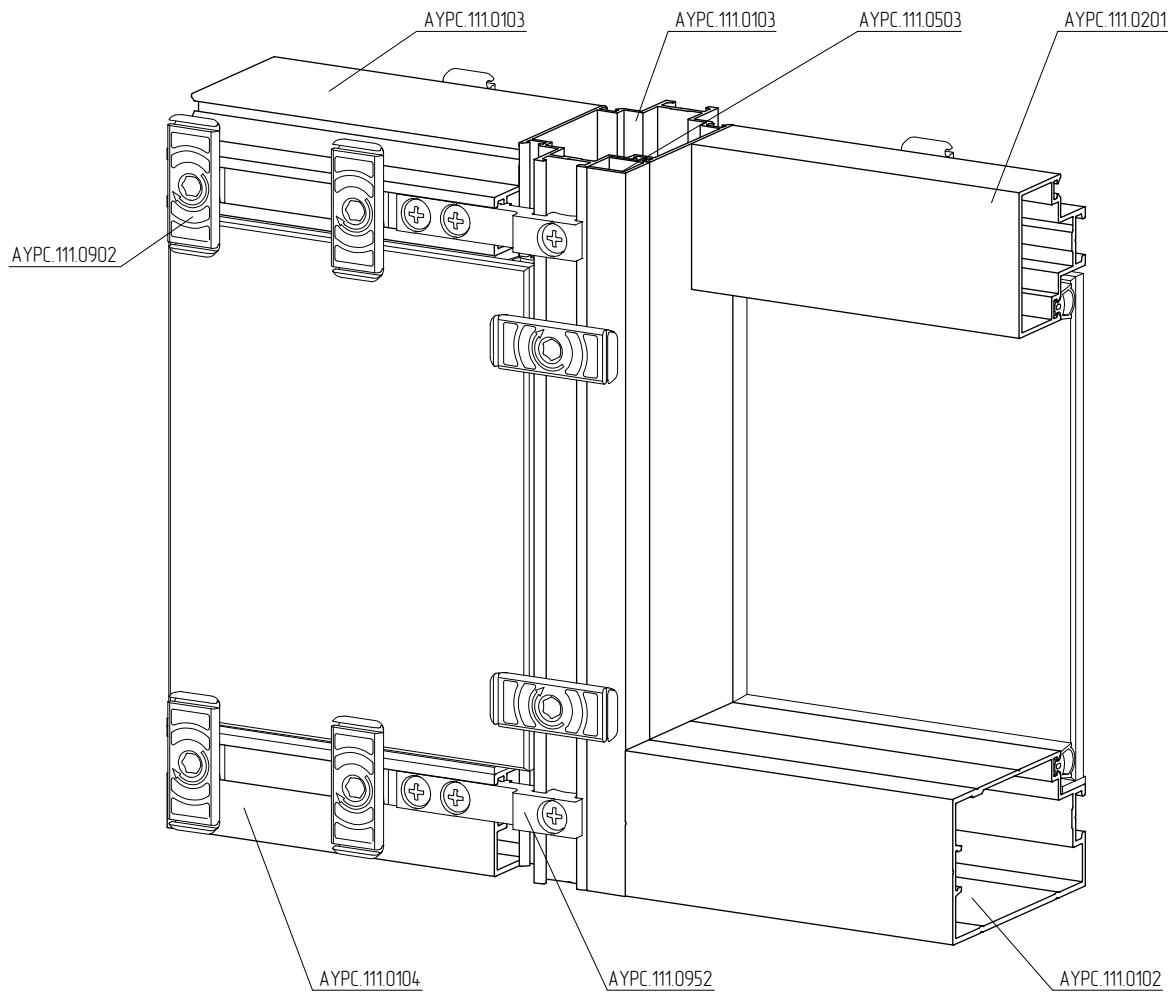
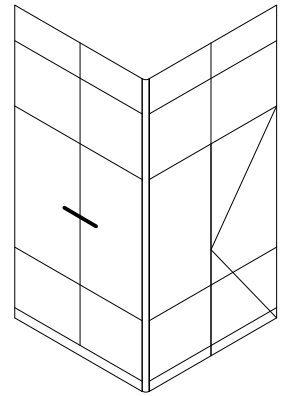
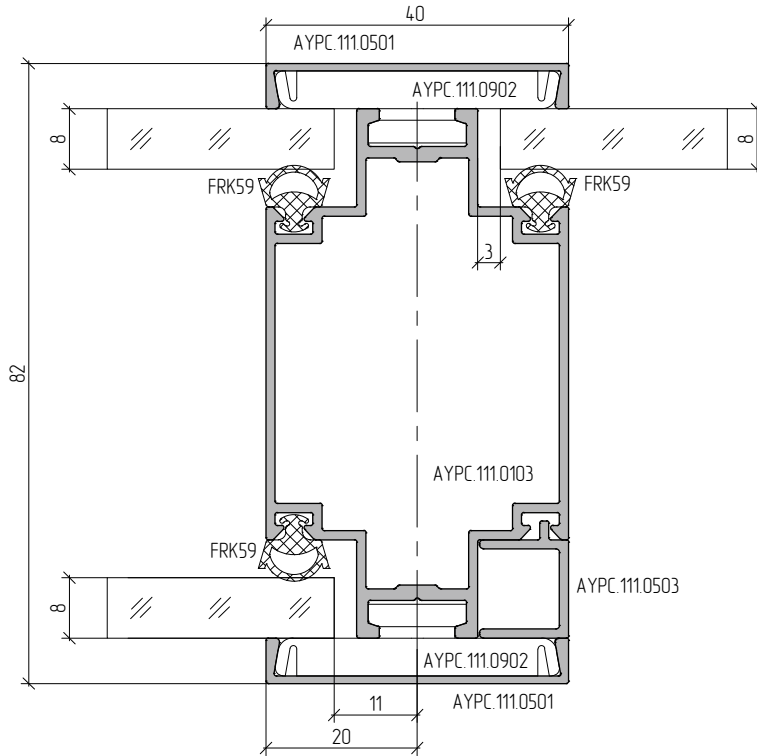

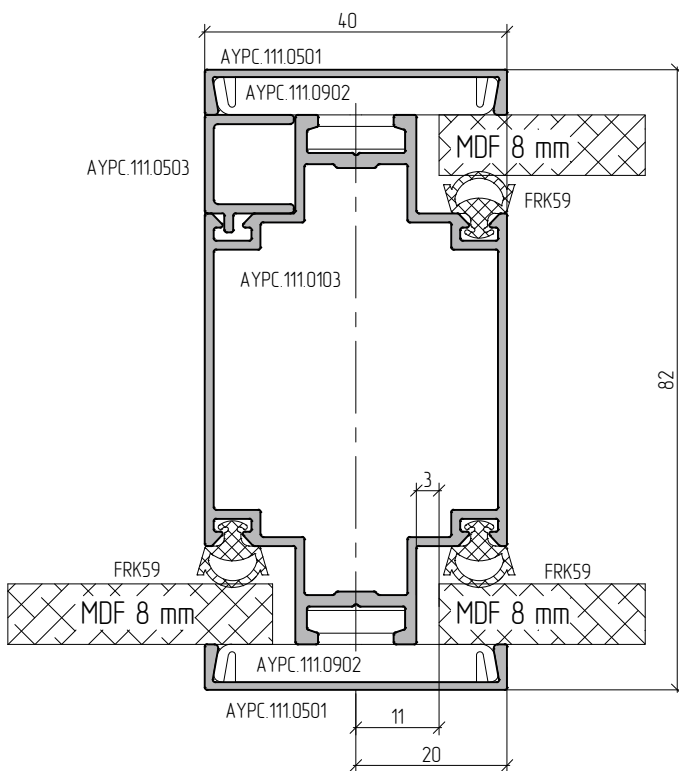
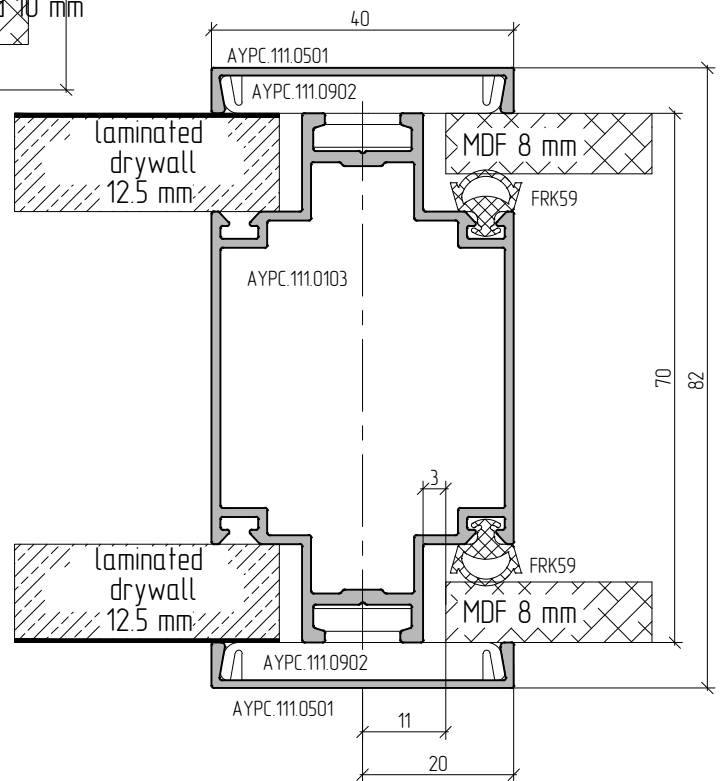
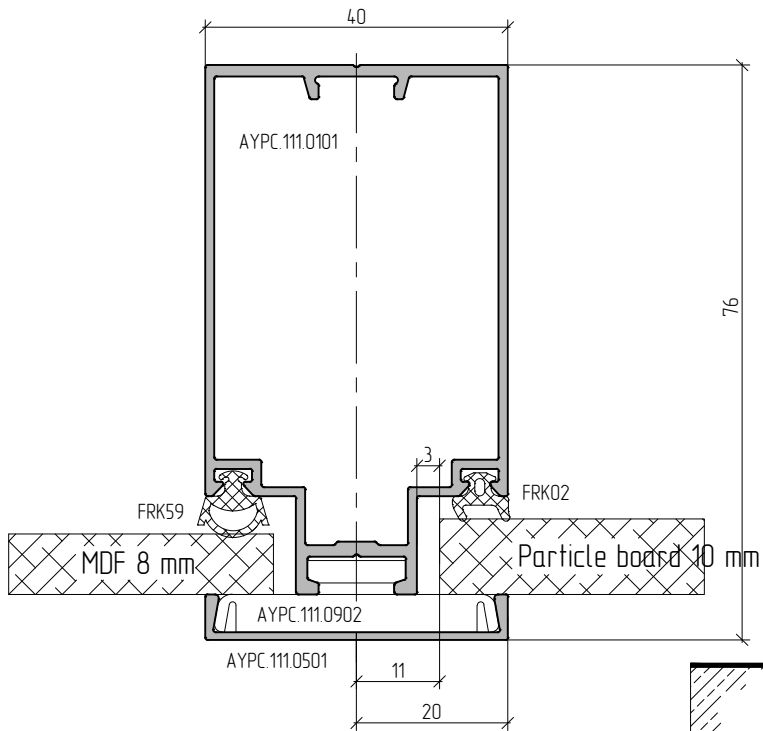
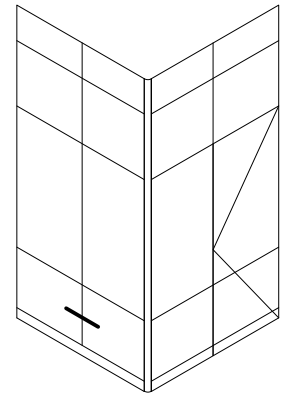

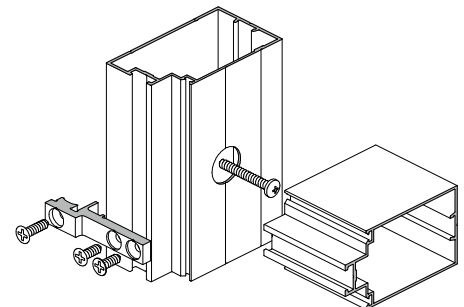
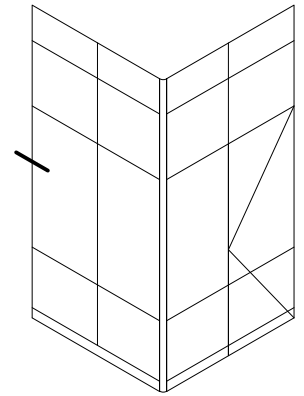
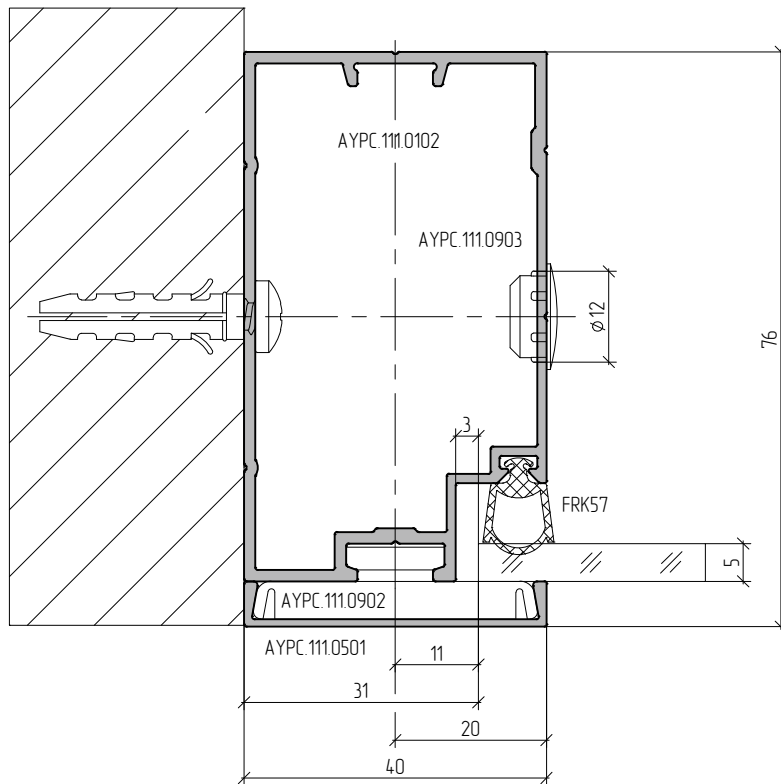

Do not install AYP.C.111.0903 plug if the mullion-to-transom and mullion-to-wall connection points are matching.

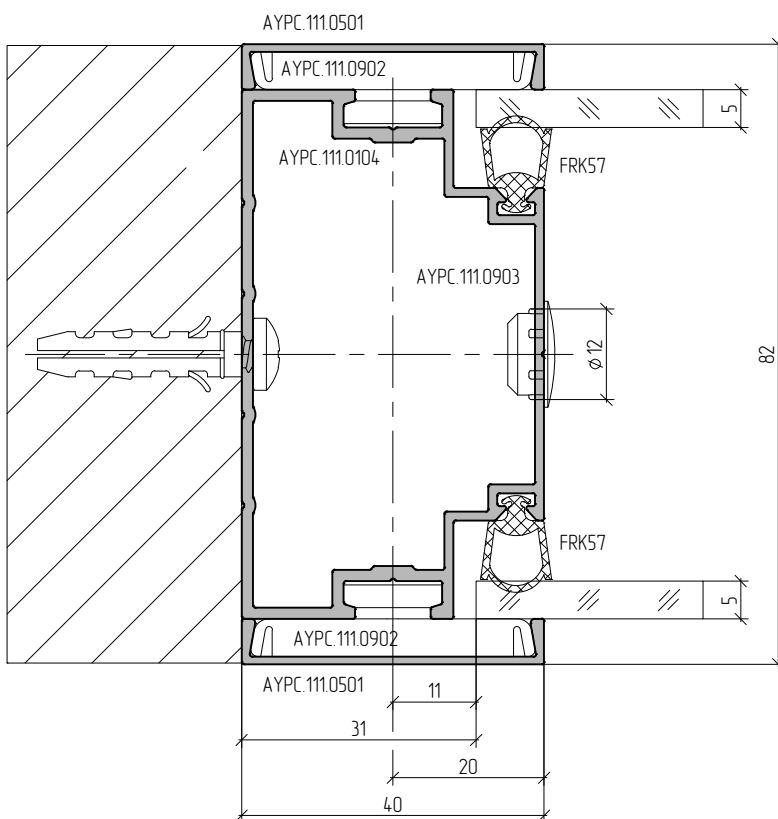

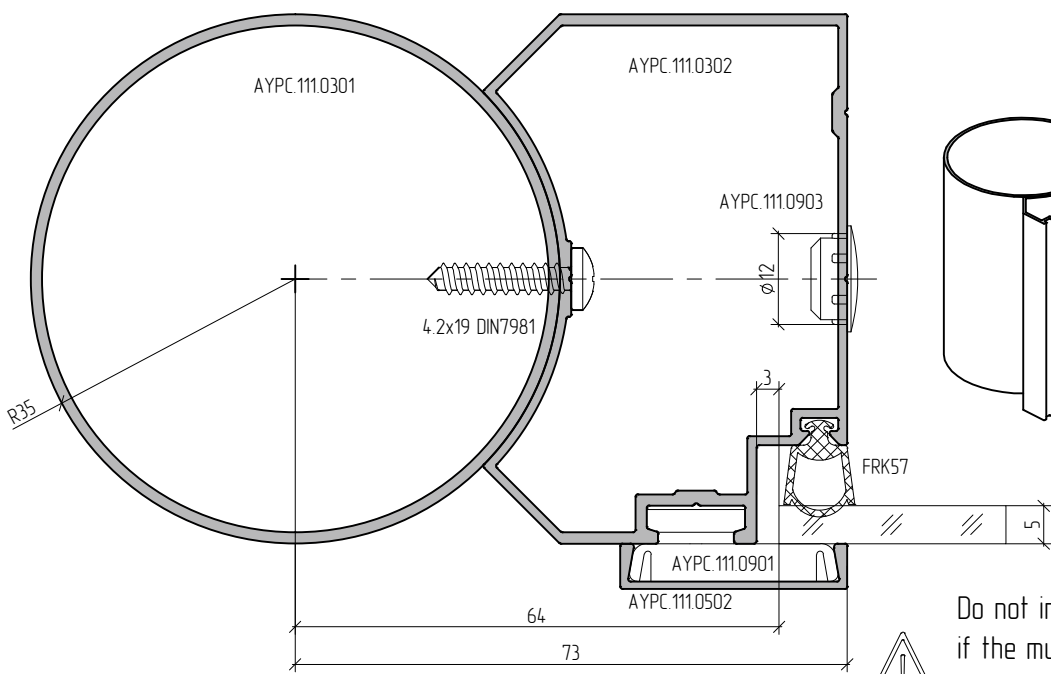
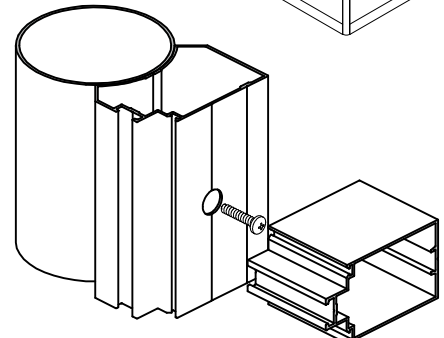
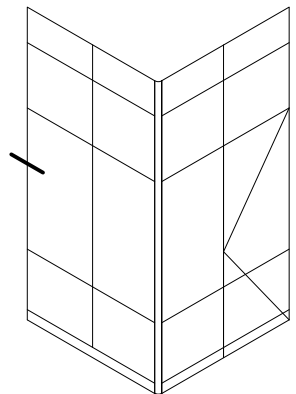

Do not install AYPC.111.0903 plug if the mullion-to-mullion and mullion-to-wall connection points are matching.

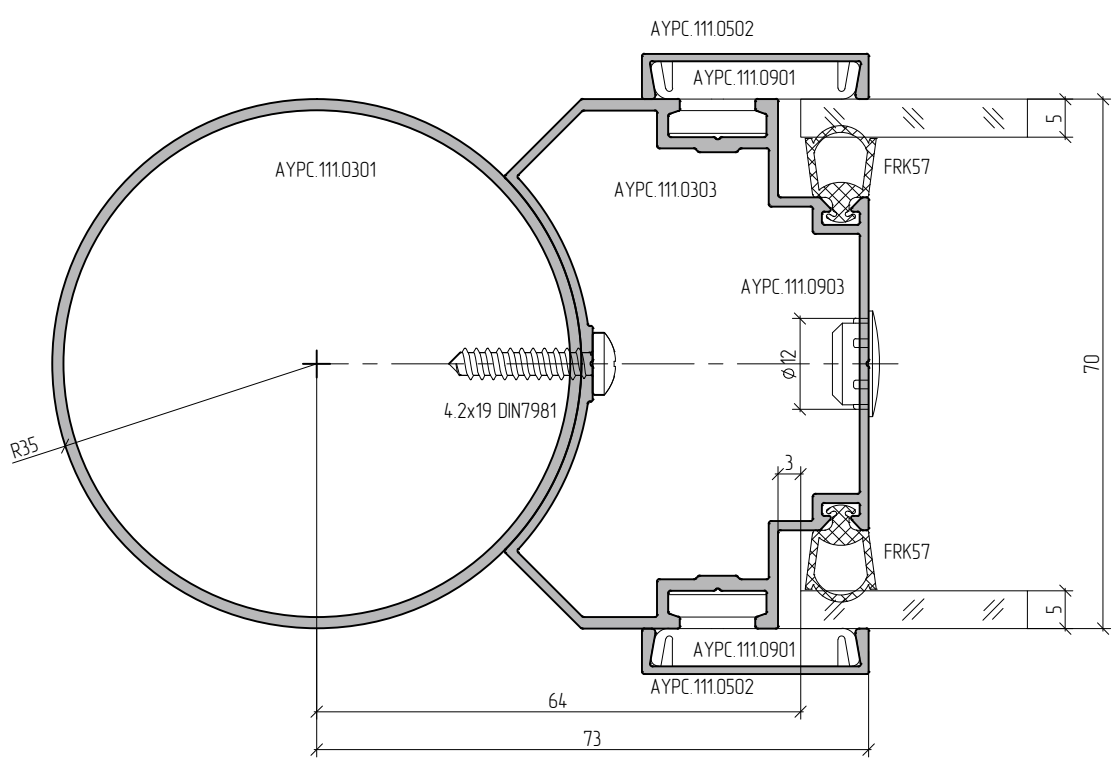

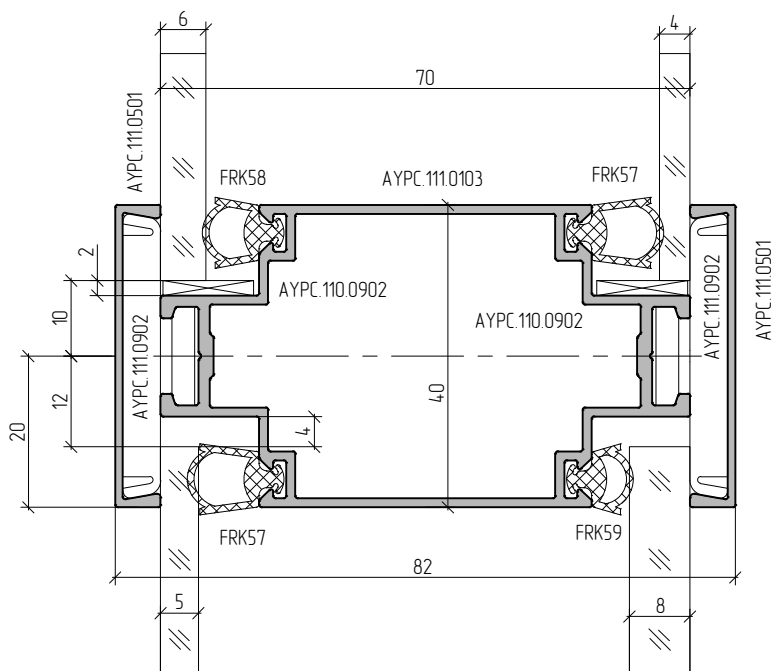
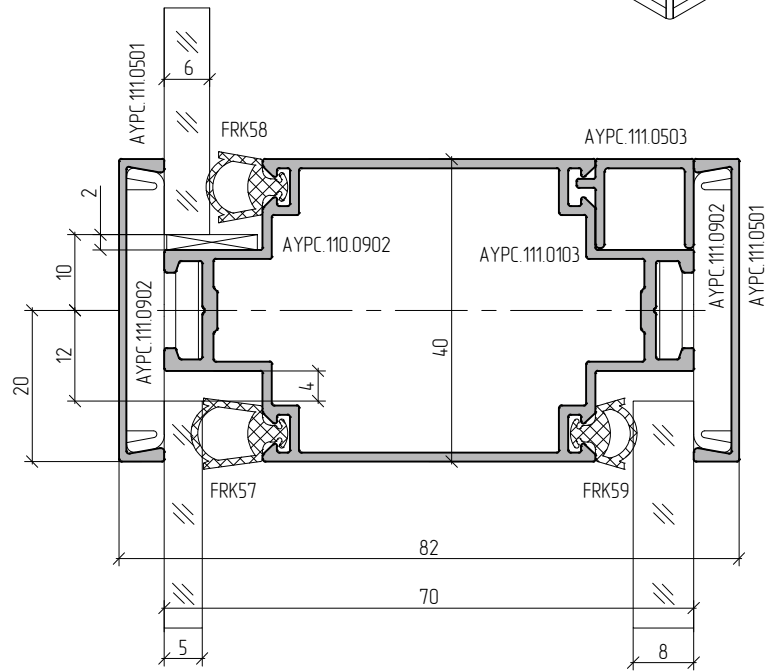
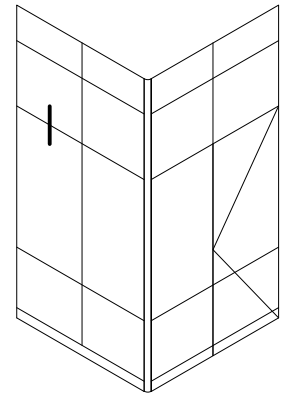
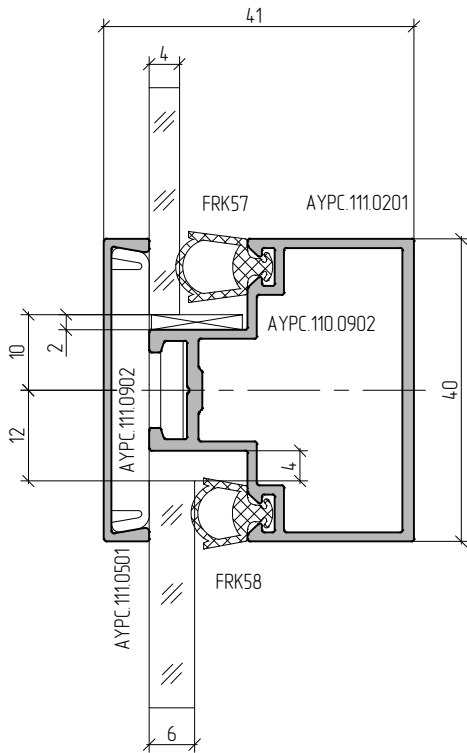



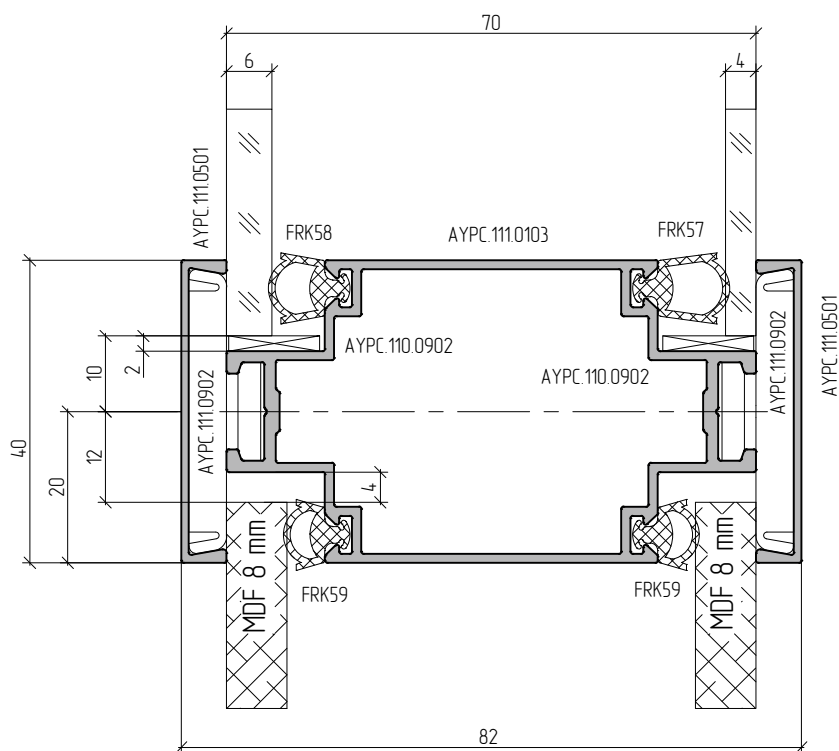
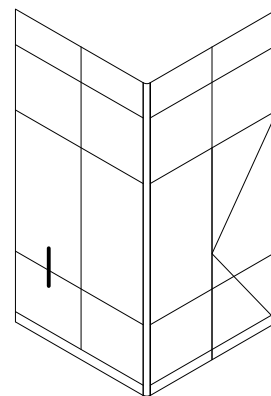
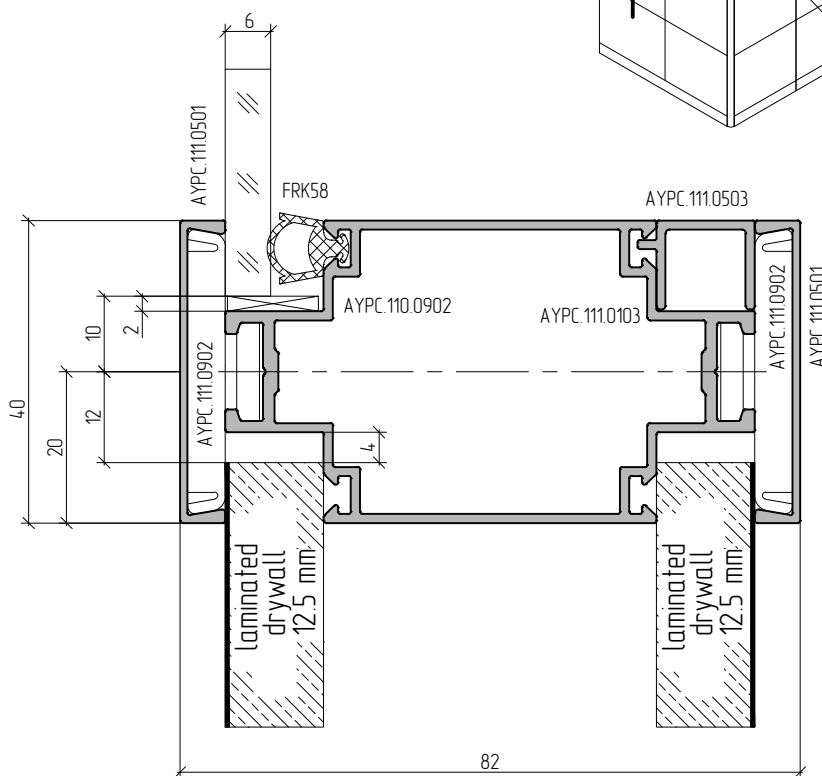
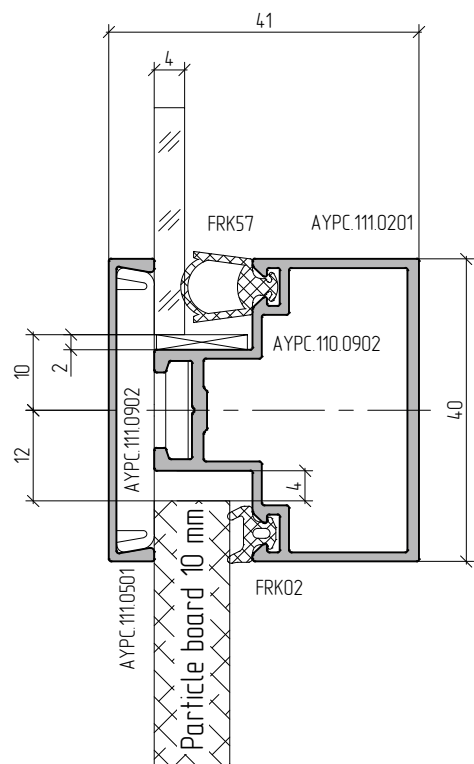

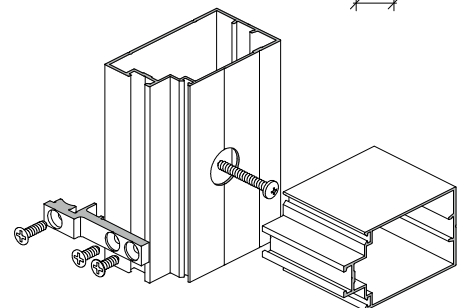
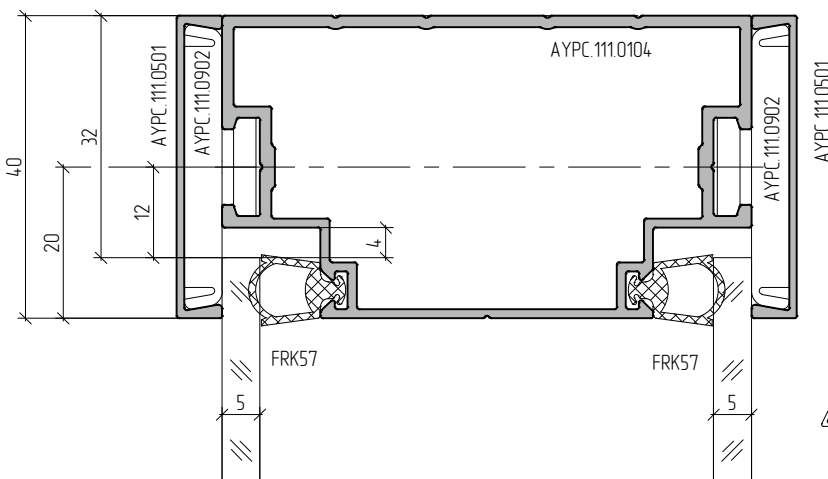
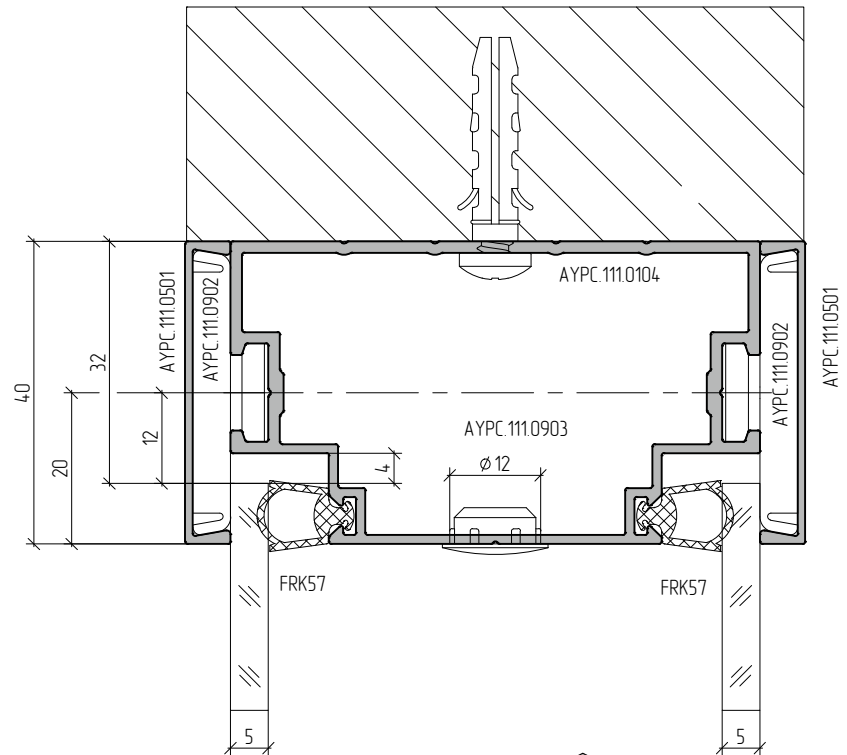
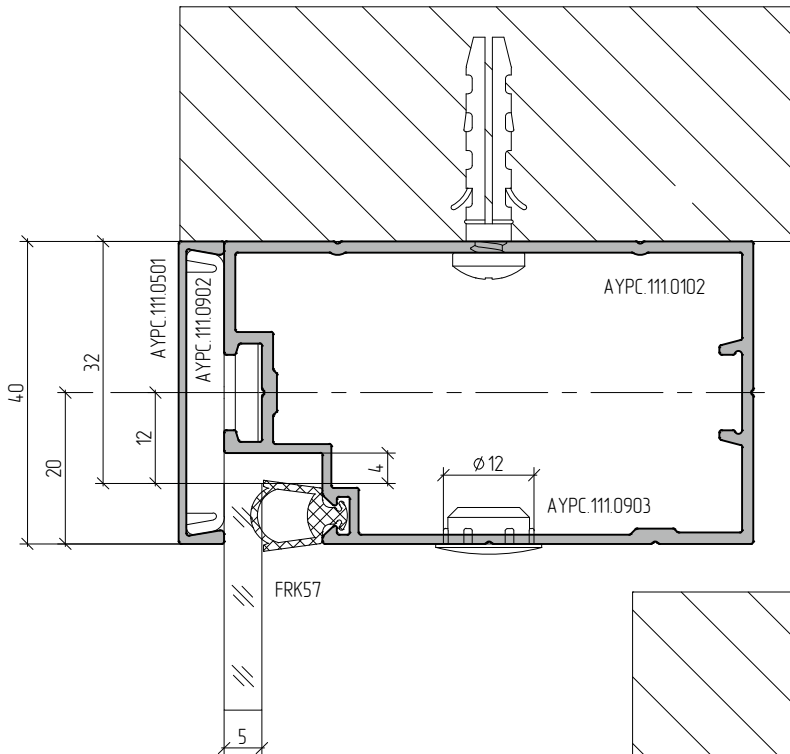
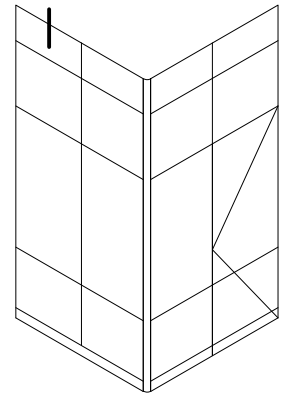

Do not install AYPC.111.0903 plug if the mullion-to-transom and transom-to-ceiling connection points are matching.



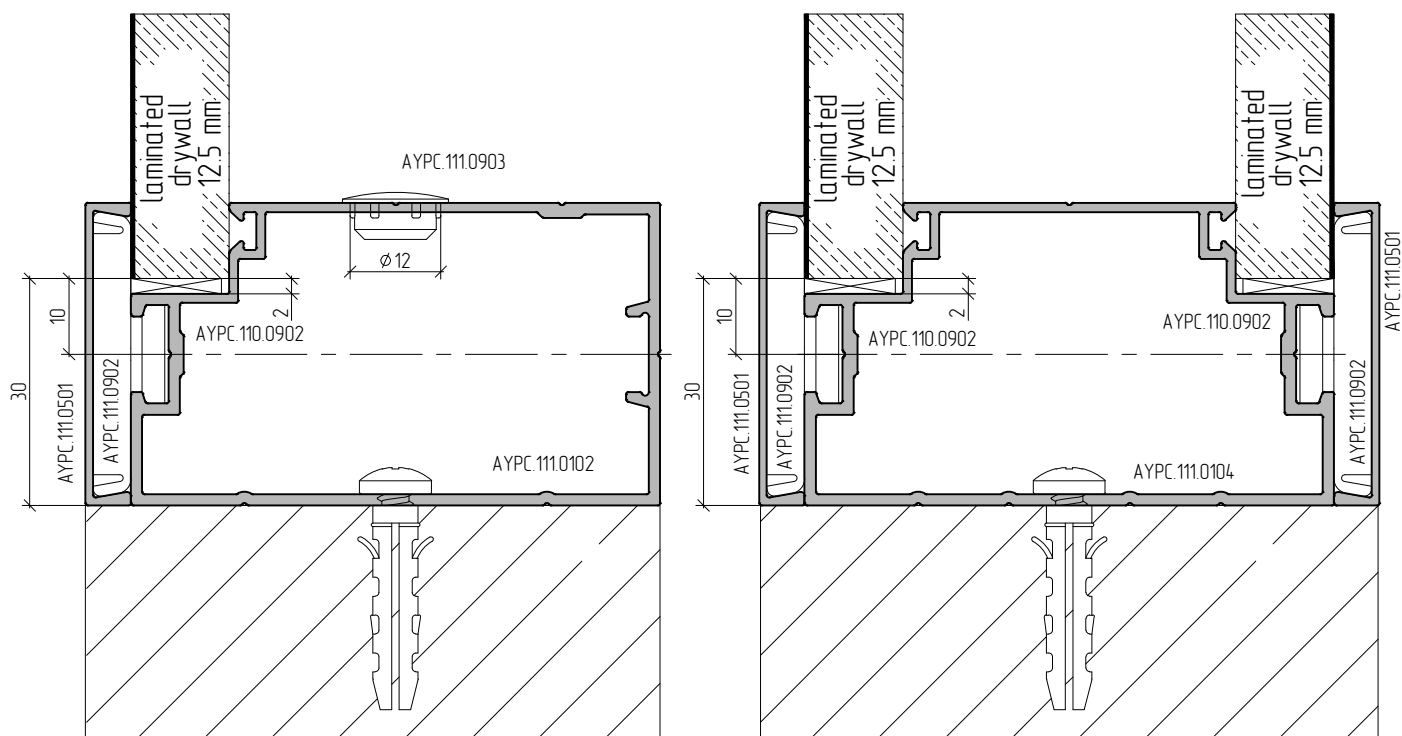
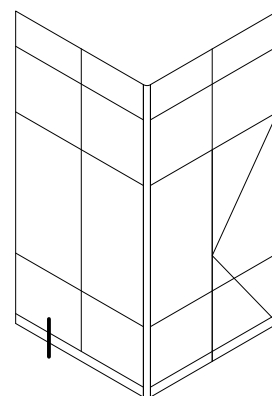
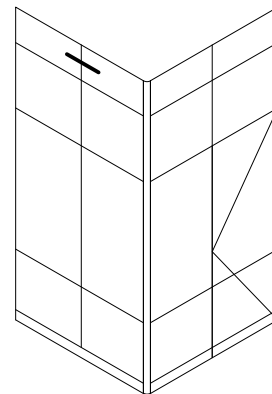
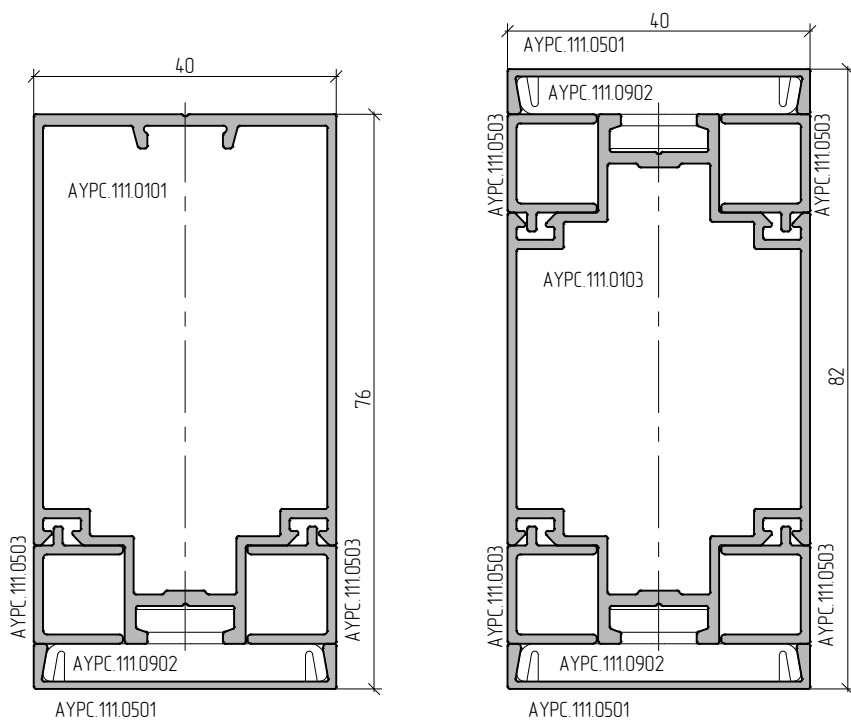

Installation on finished floor with carpet

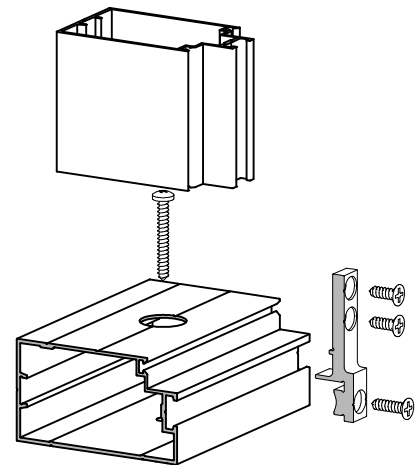
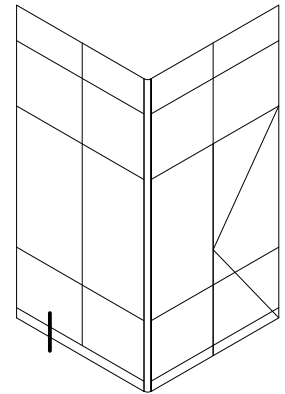
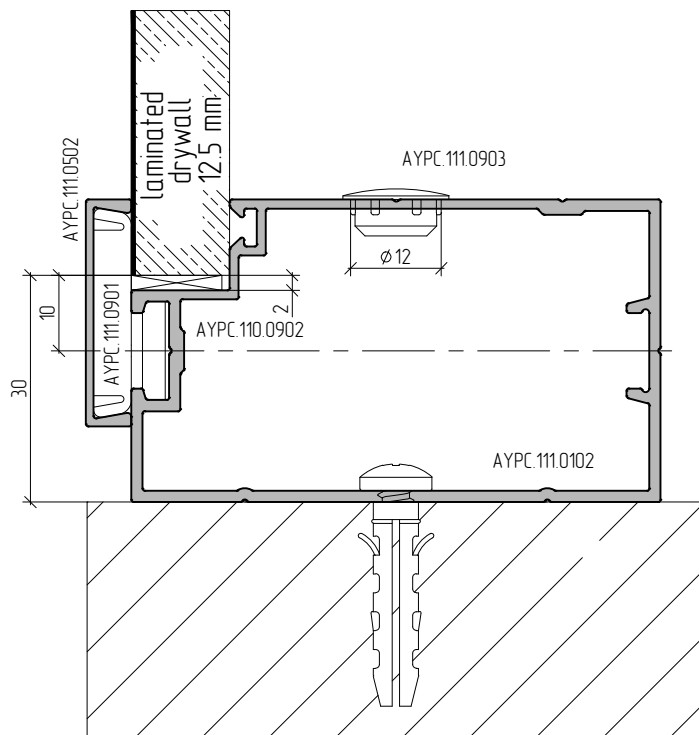

 Attention

No AYPC.111.0903 plugs are required in the mullion-transom junction.

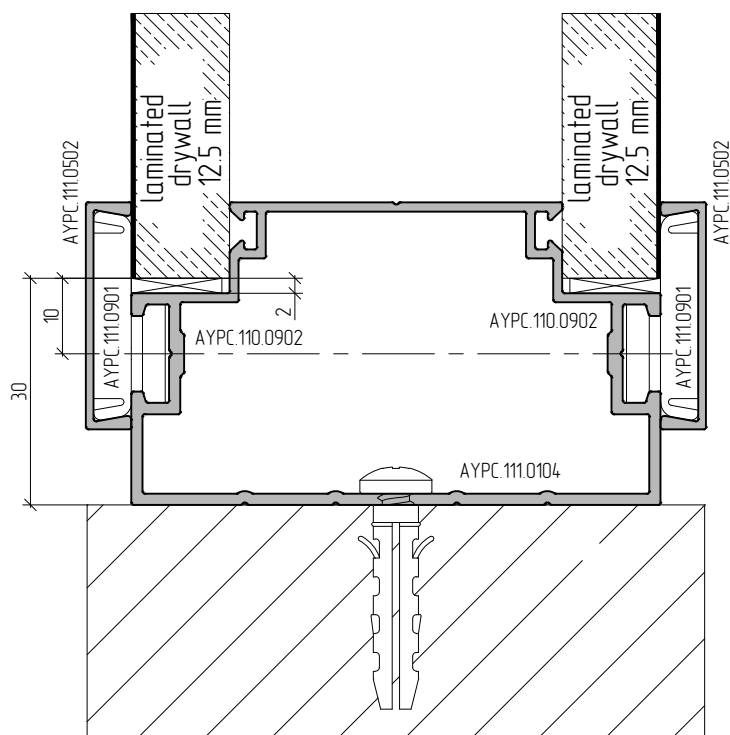

Installation on finished floor with carpet

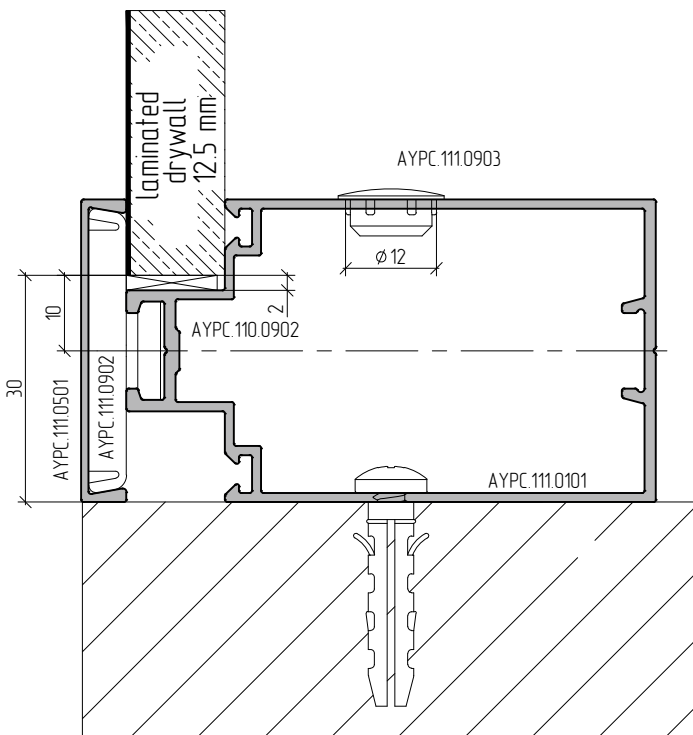
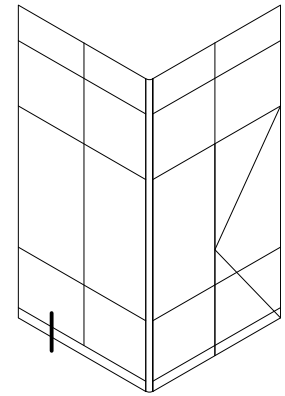

Installation steps

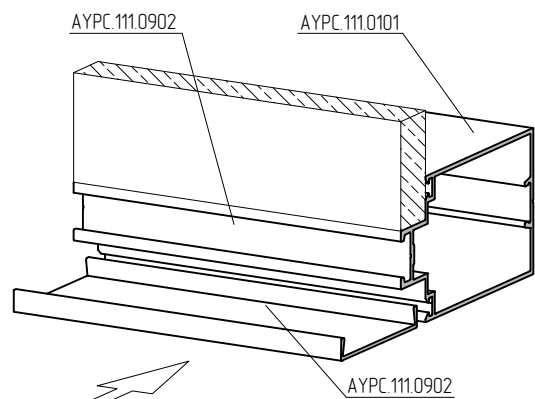

1. Install AYPC.111.0501 cover profile into AYPC.111.0101 or AYPC.111.0103 profile groove. Install AYPC.111.0902 clamp profile.

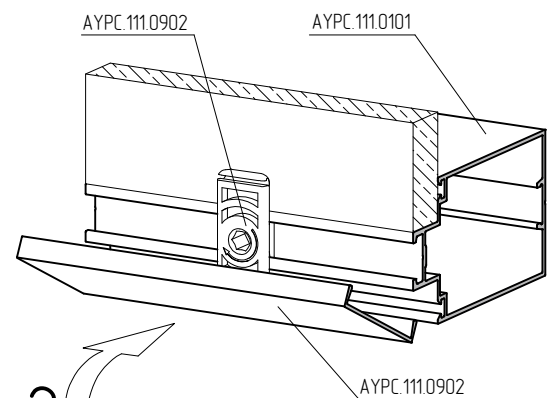
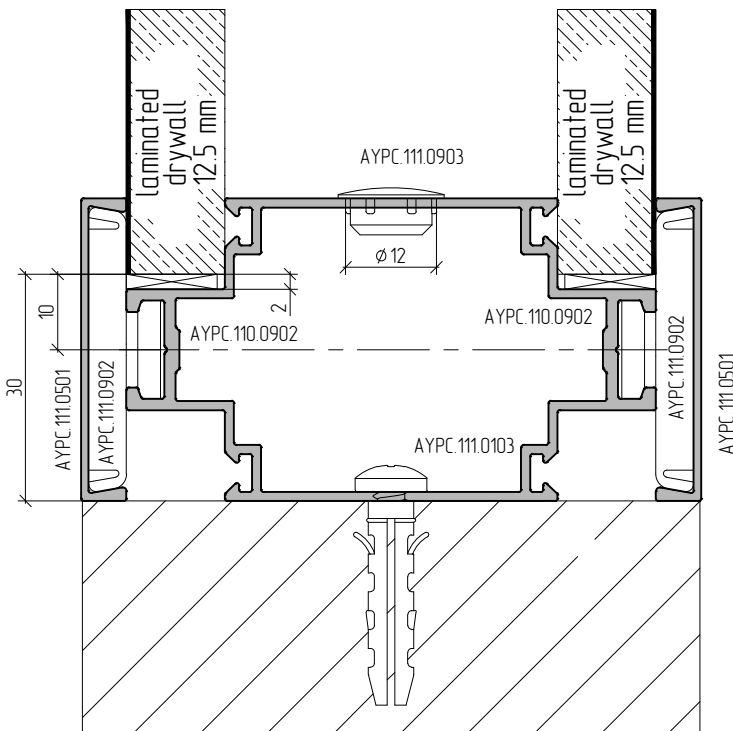

2. Pull AYPC.111.0501 cover profile and turn until it clicks.

Options of using AYPC.111.0116 leveling profile

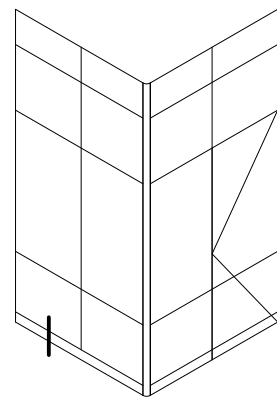
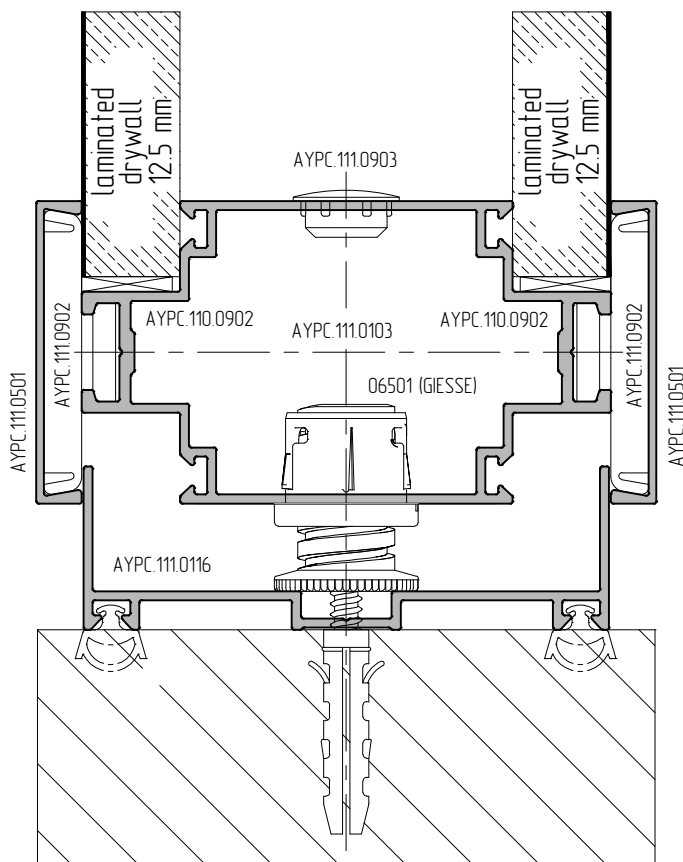
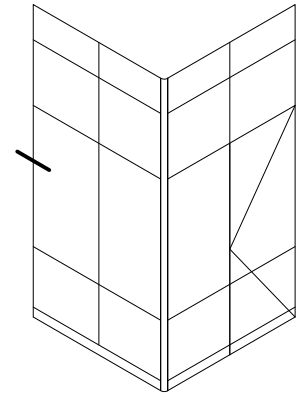
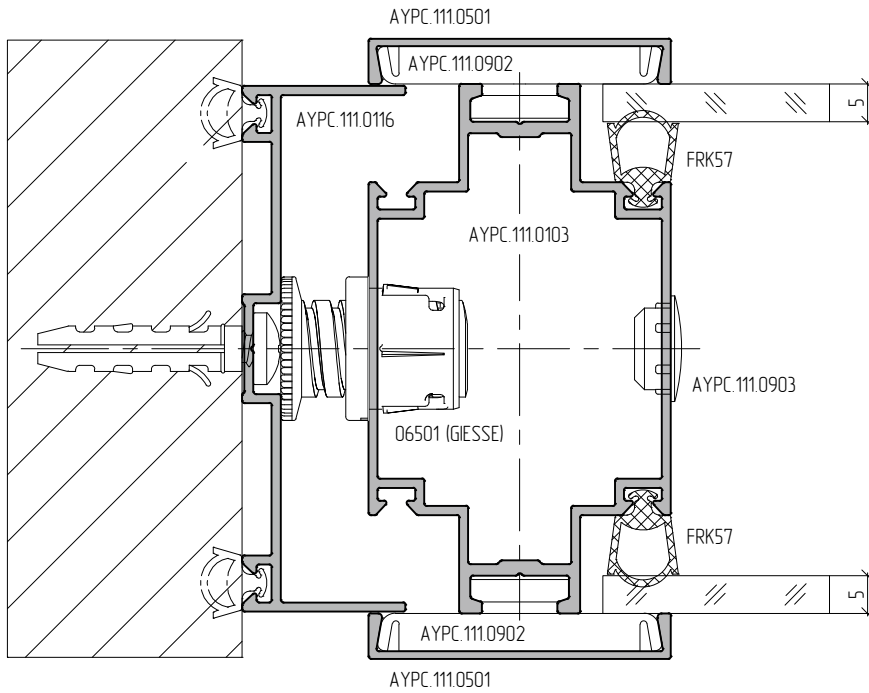

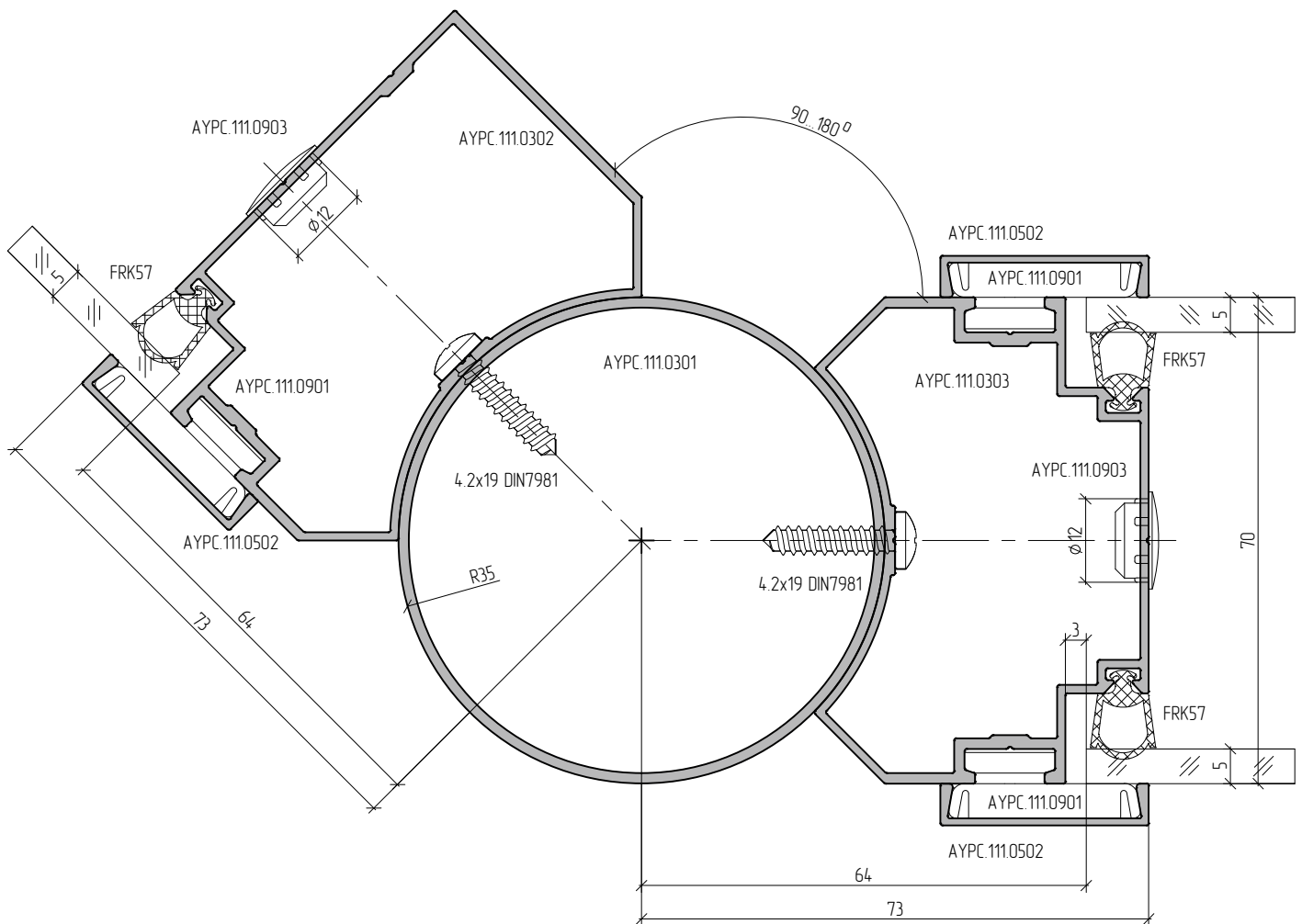
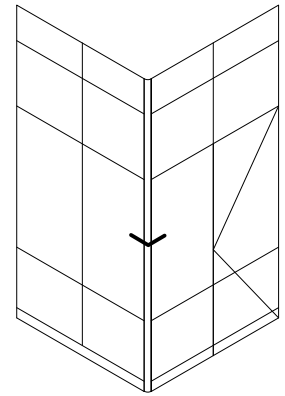

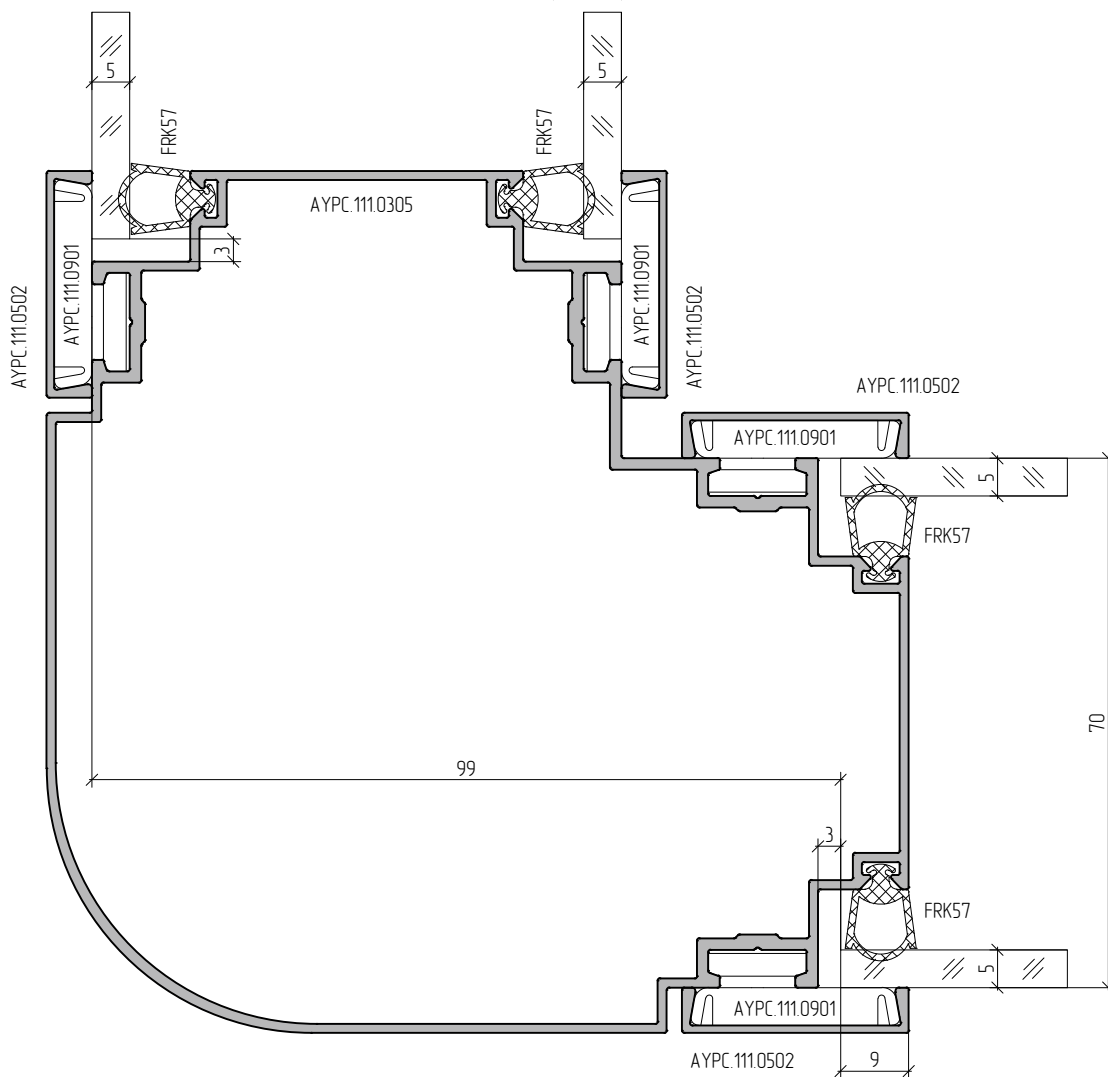
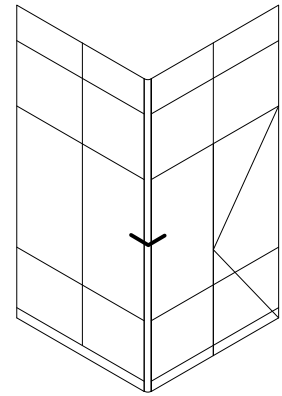
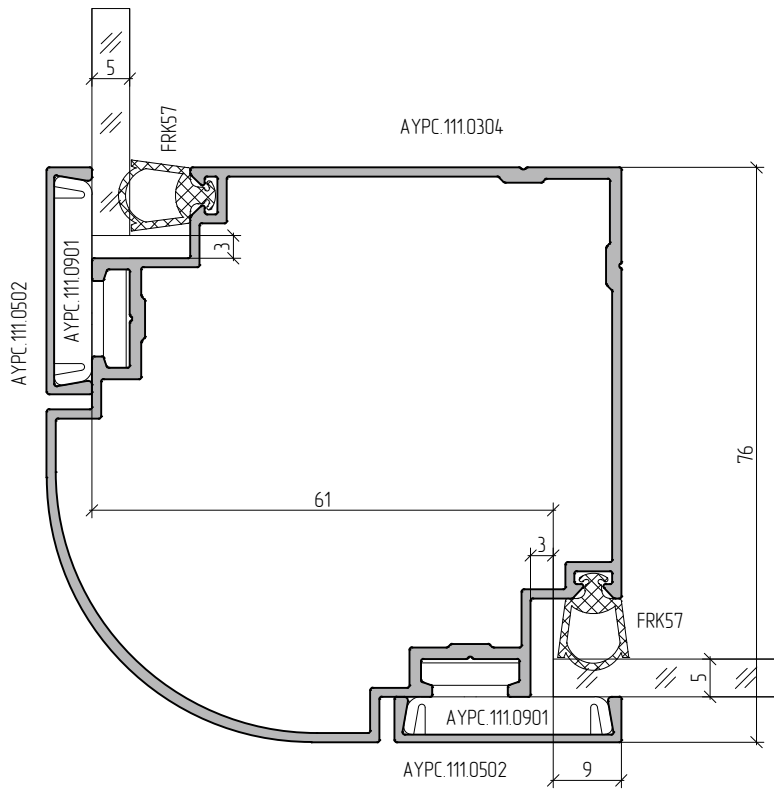



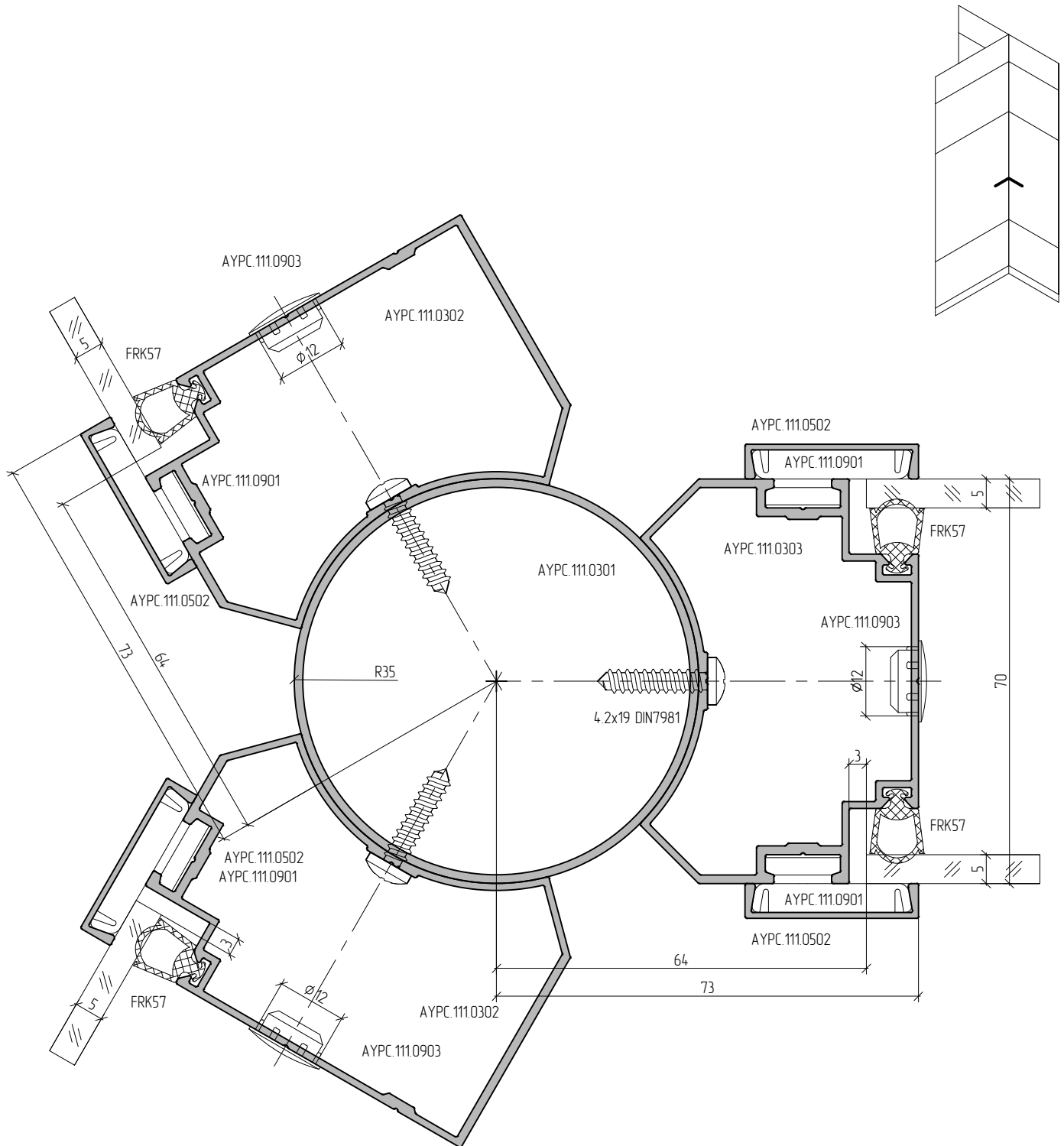

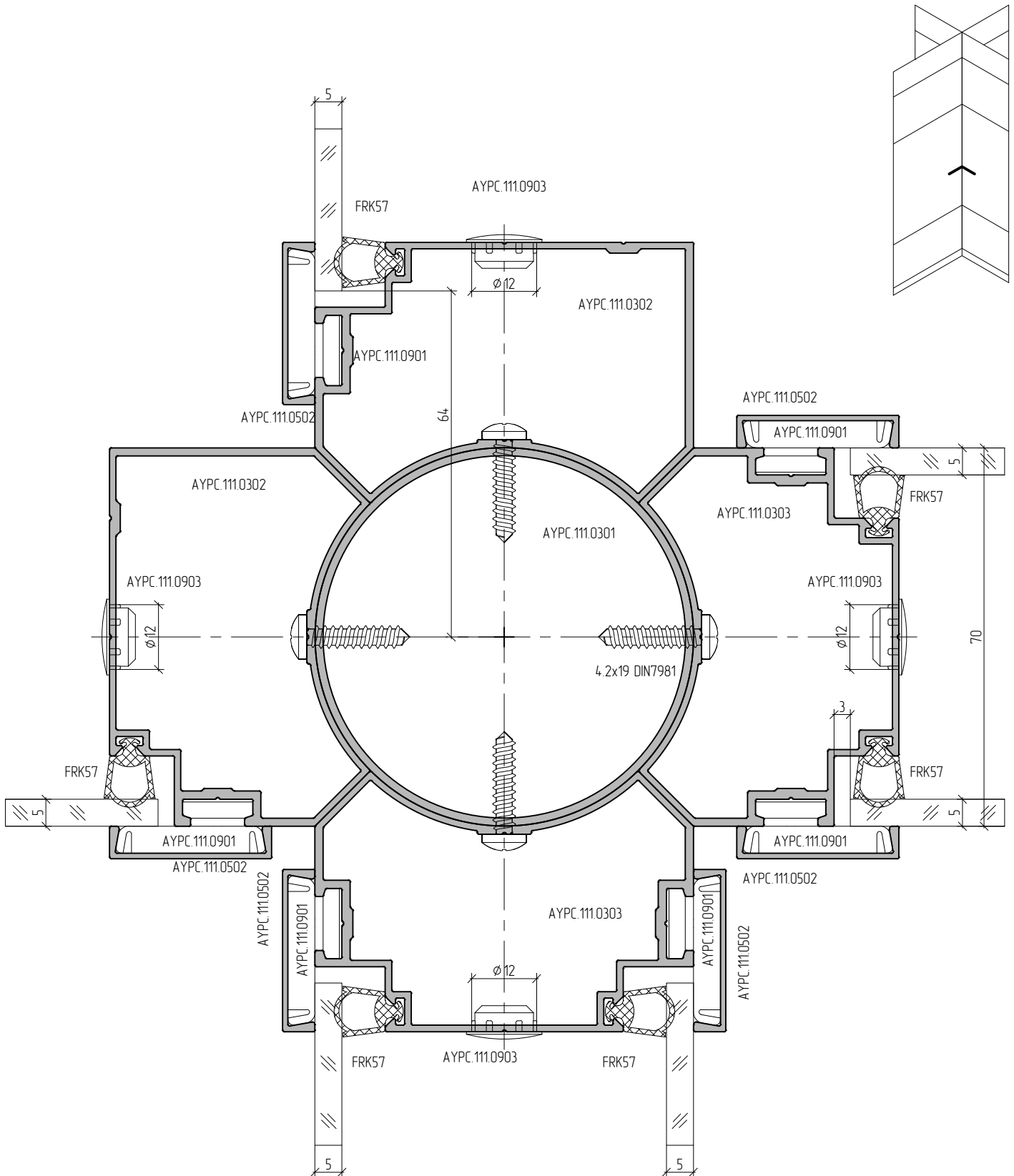

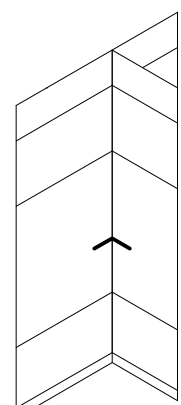
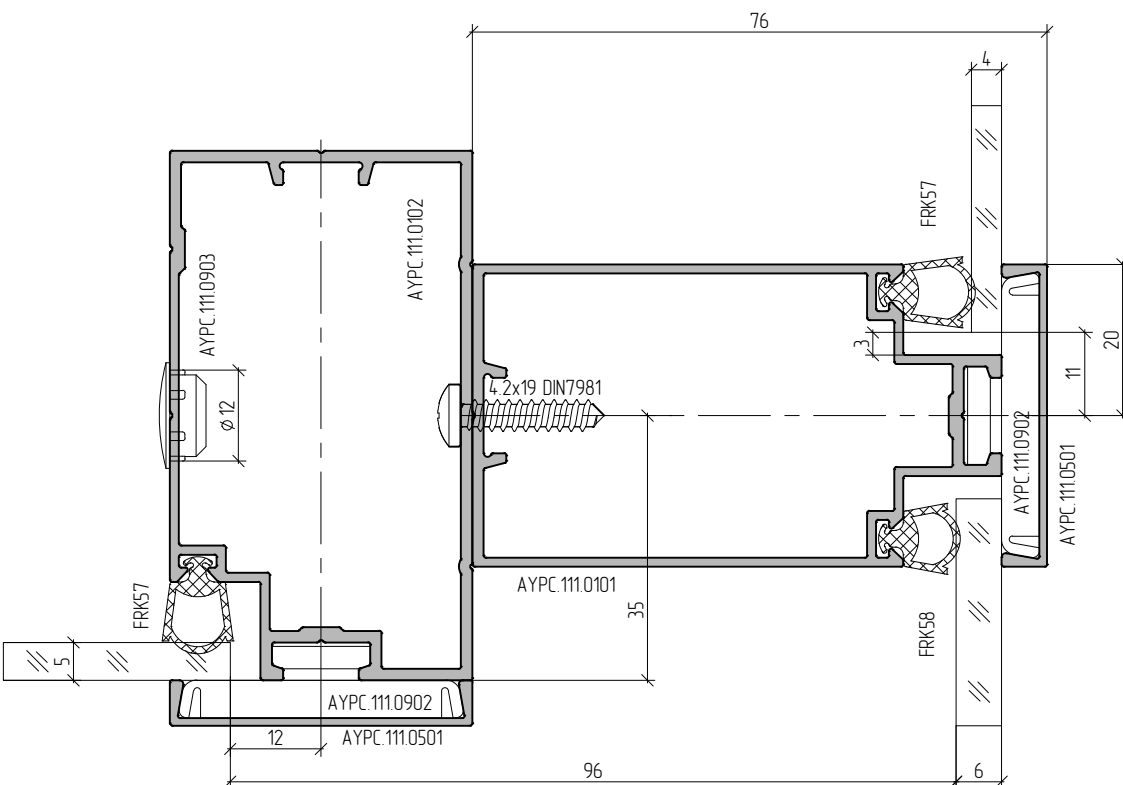
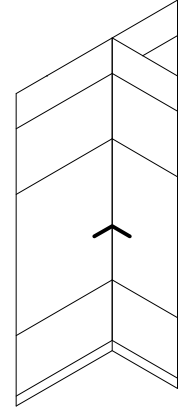
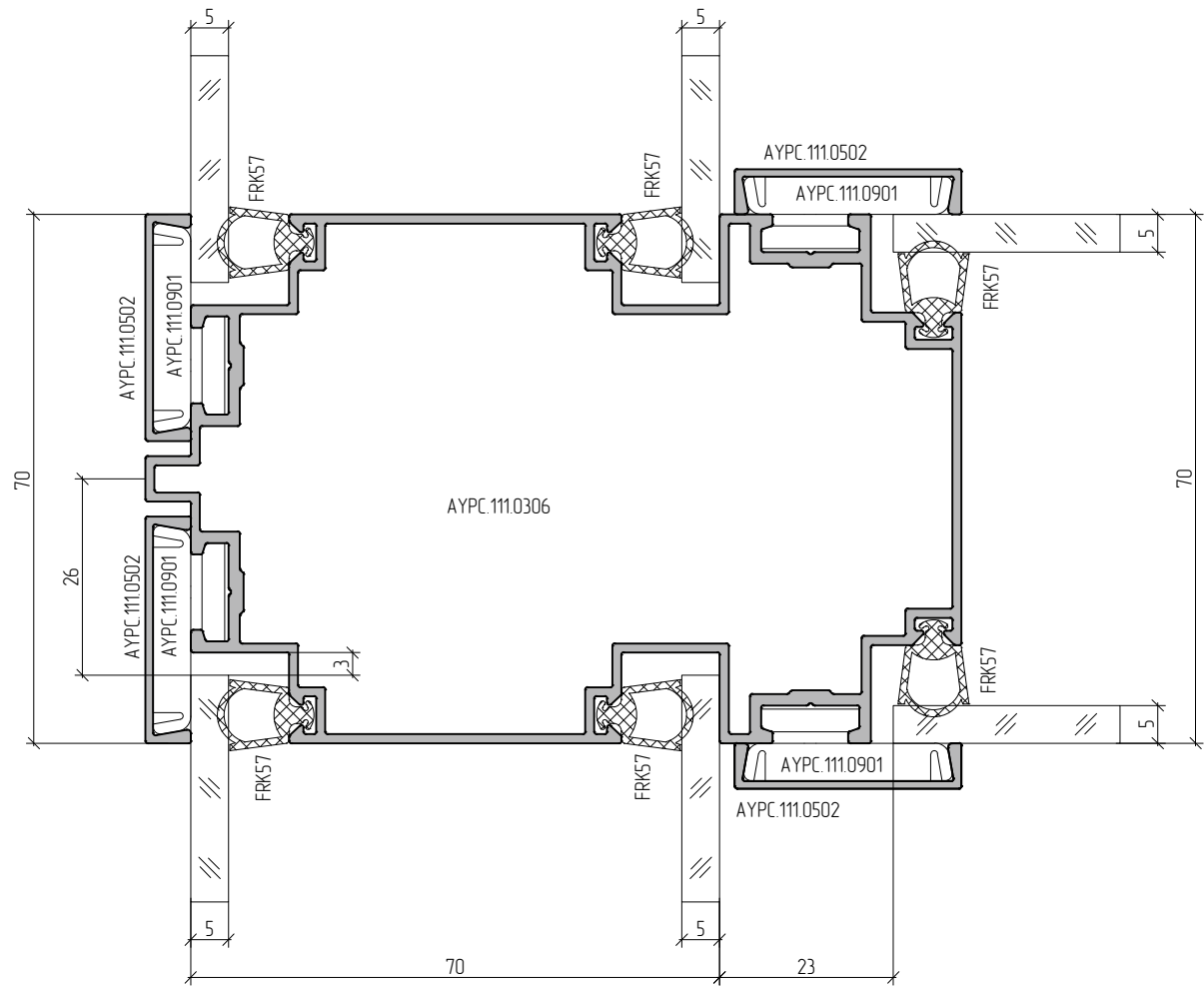

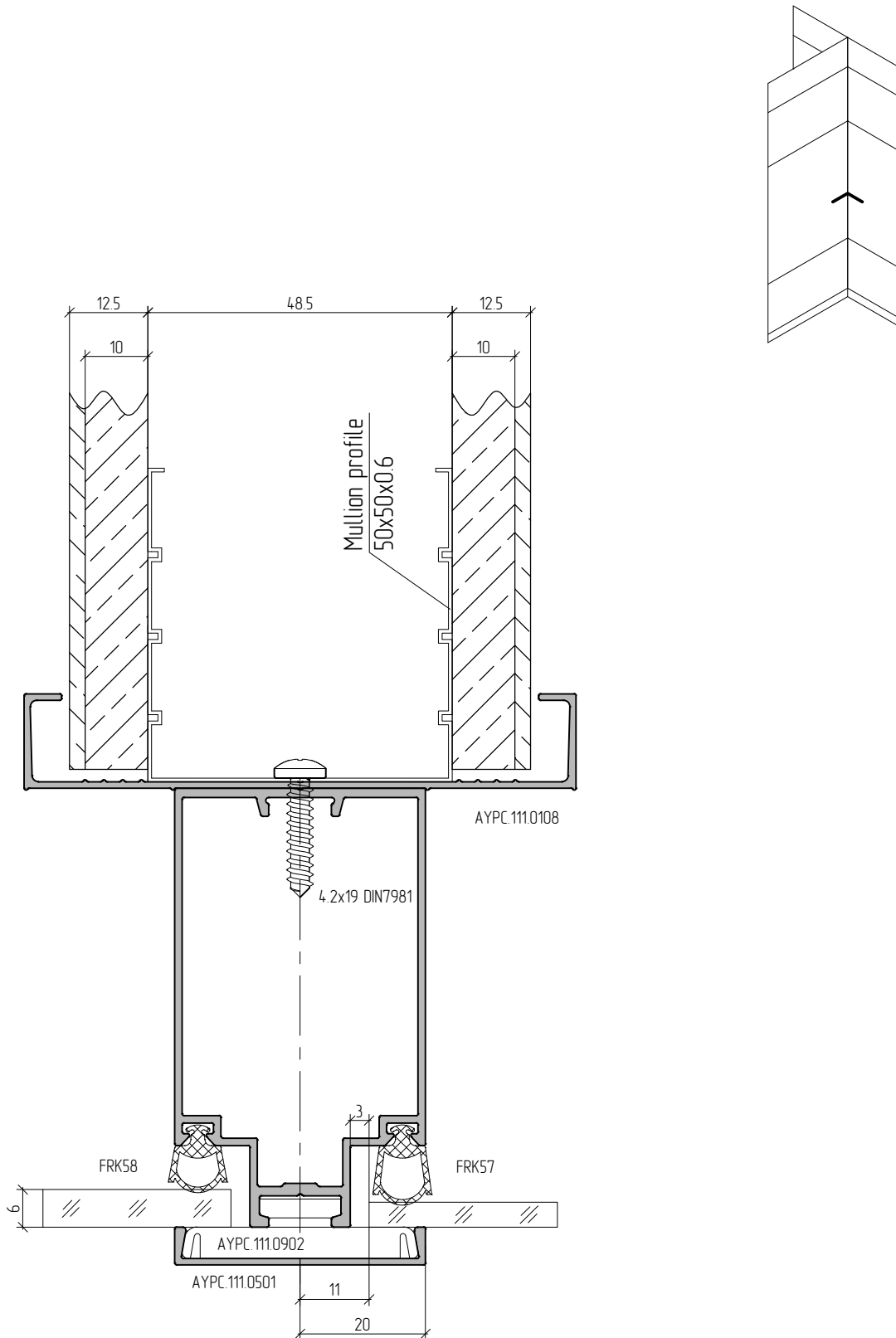

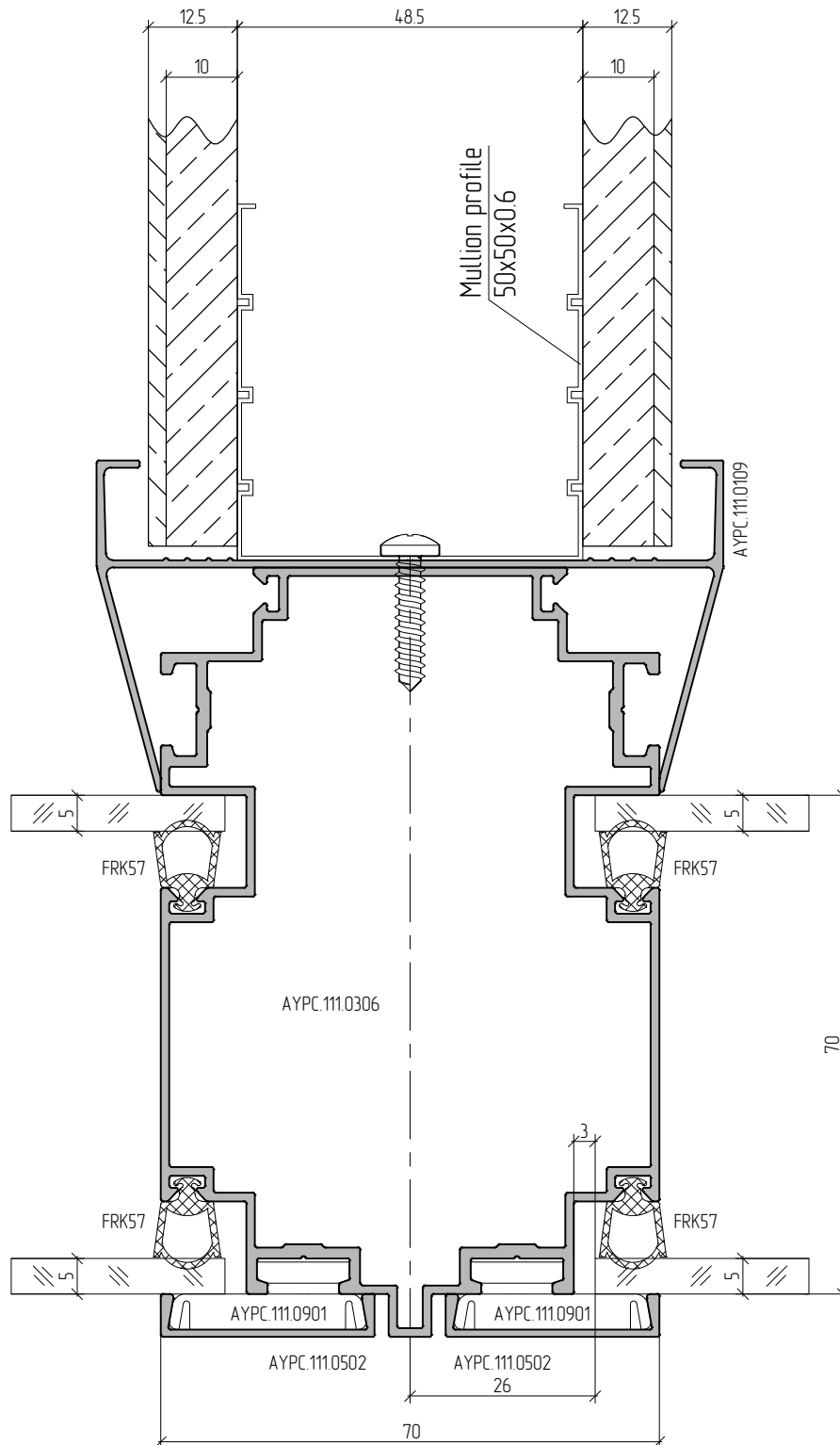
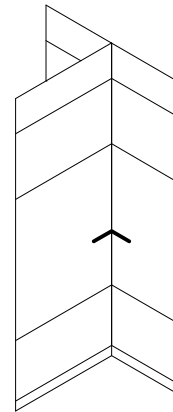





**ALUTECH ALT 111**  
Interior partition system

Doors. Sections.  
Processing and assemblage

01

02

03

04

05

06

07

08

09

**10**

11

12

13

14





- 01
- 02
- 03
- 04
- 05
- 06
- 07
- 08
- 09
- 10
- 11
- 12
- 13
- 14

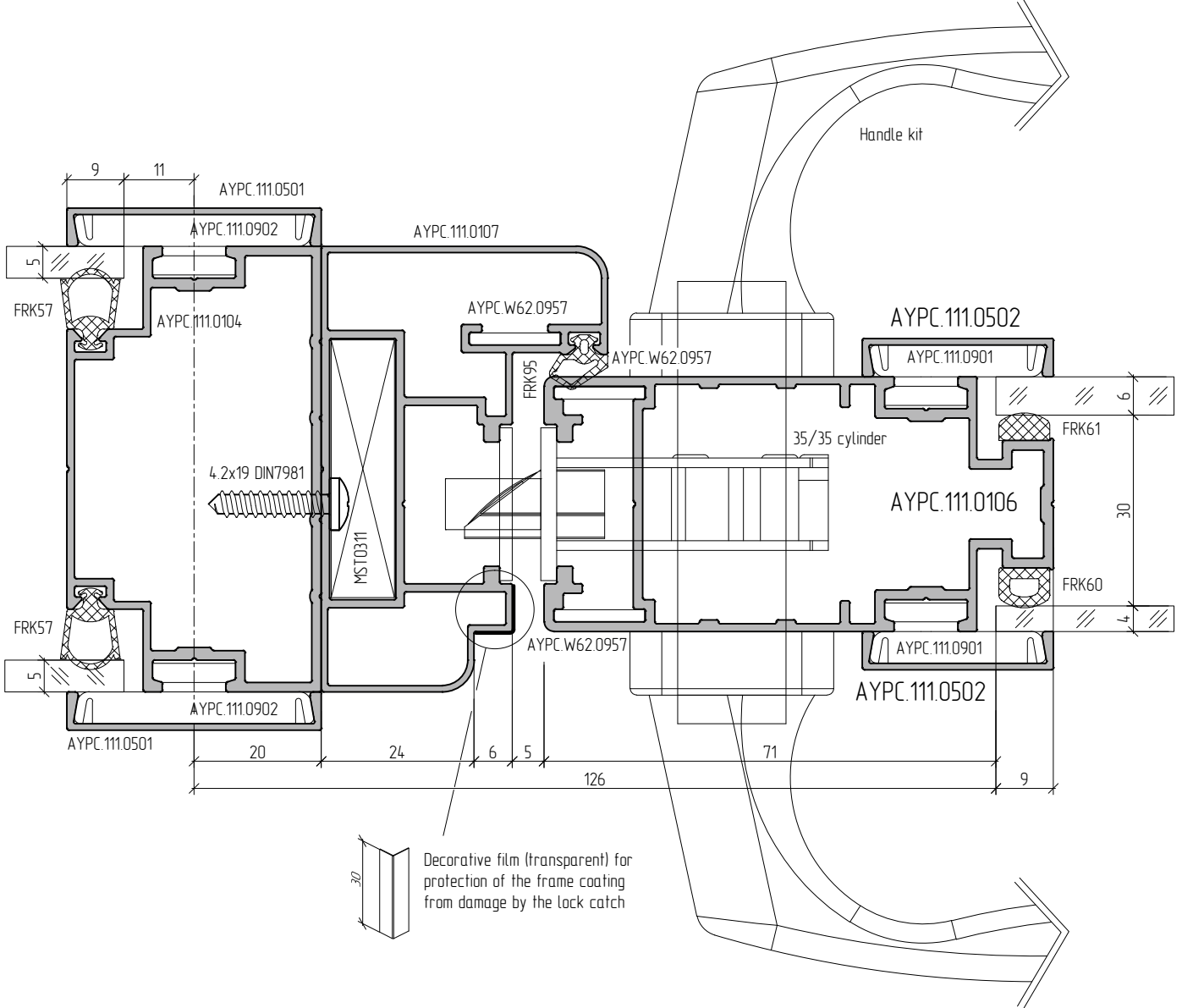
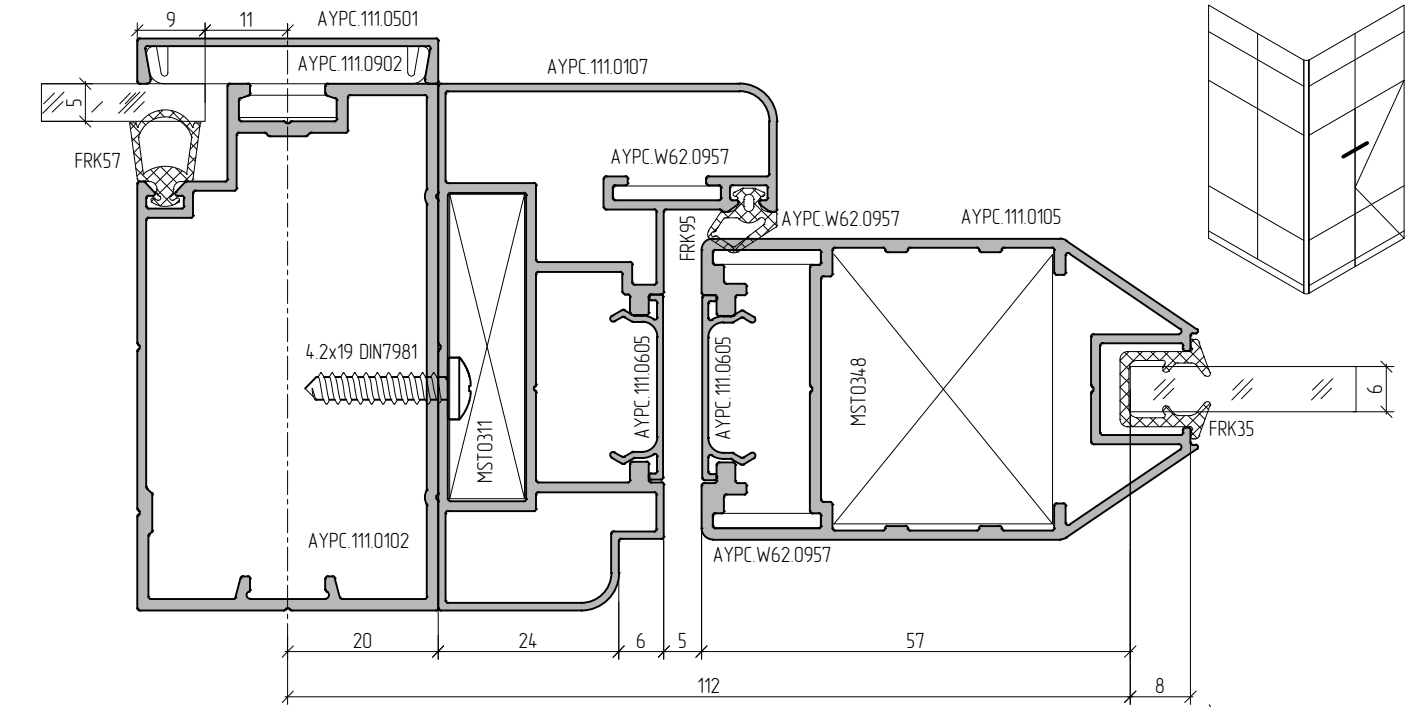

Decorative film (transparent) for protection of the frame coating from damage by the lock catch

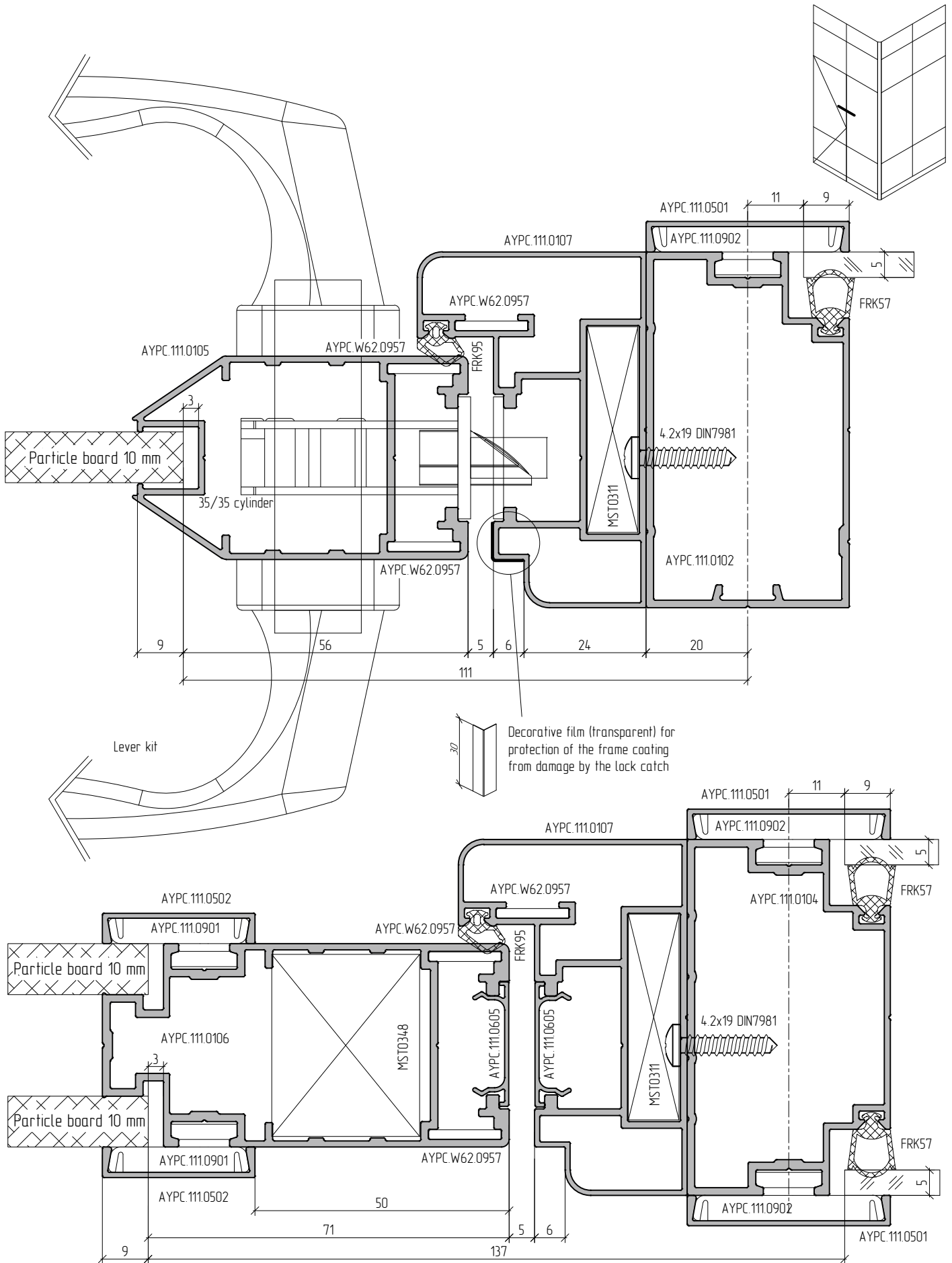

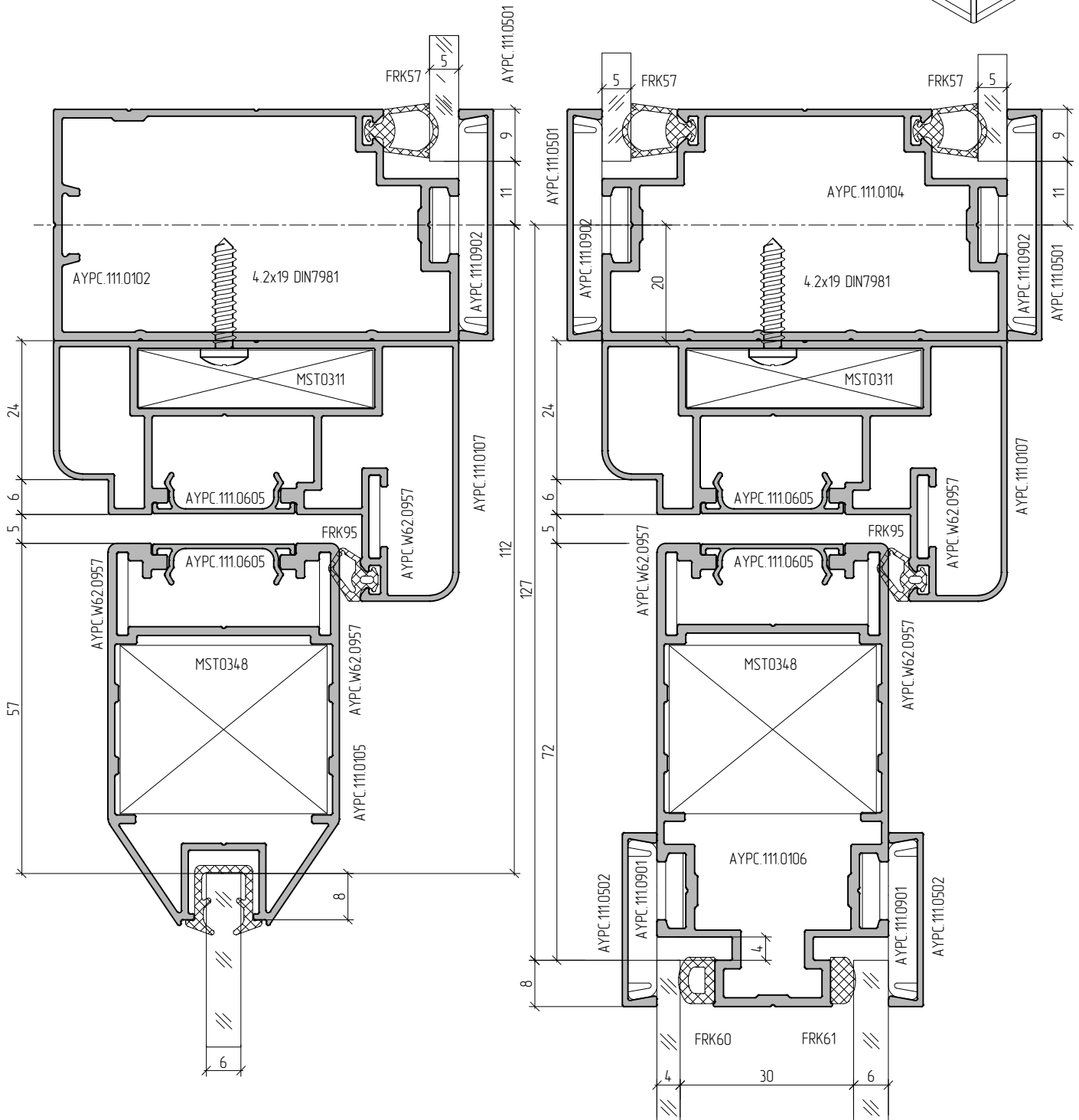
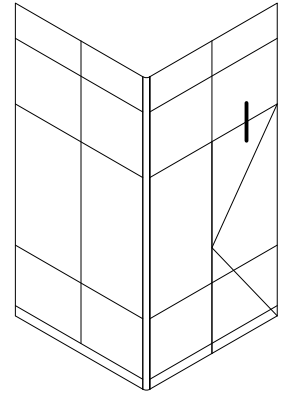

Upper joint. Door closer installation

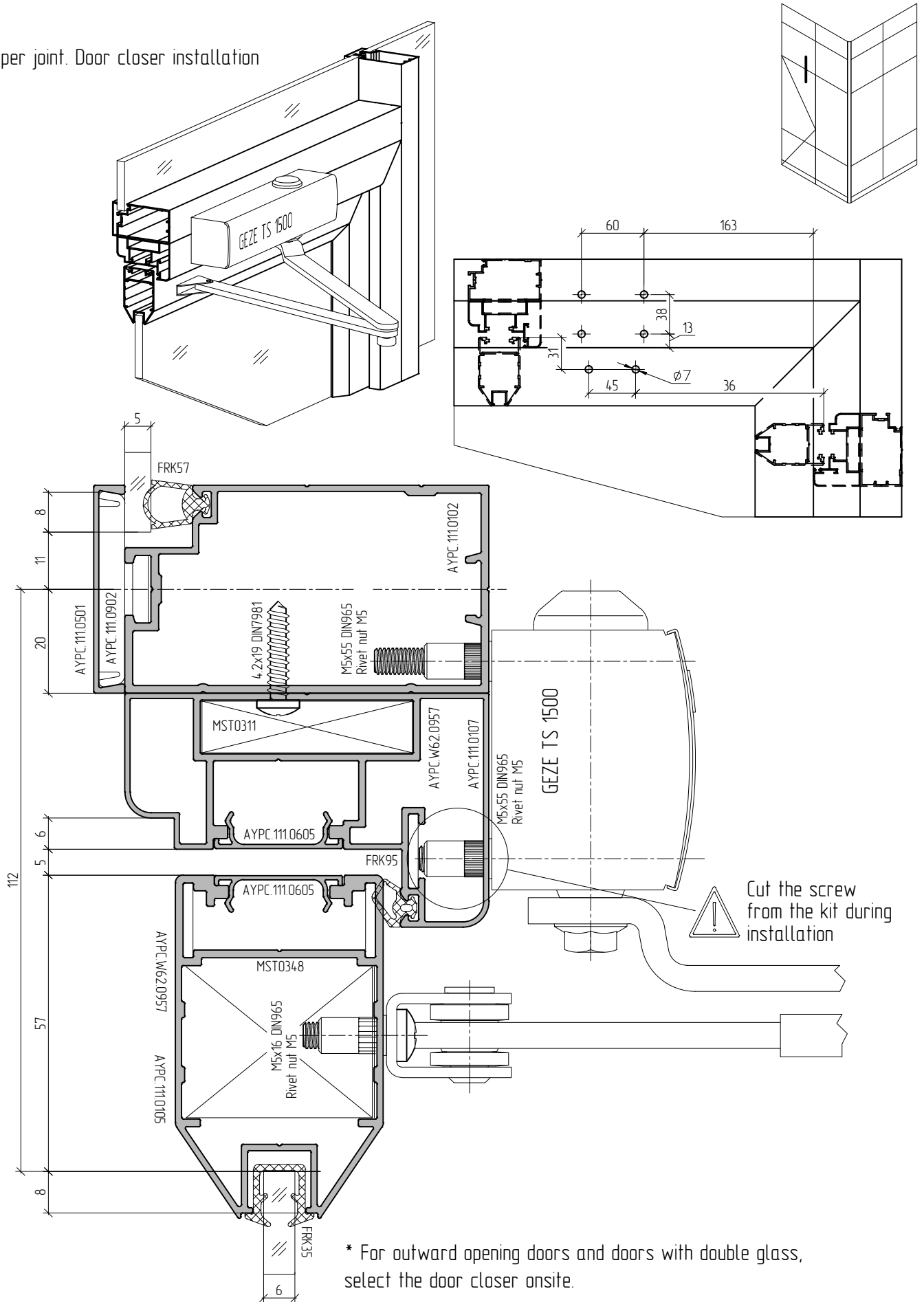

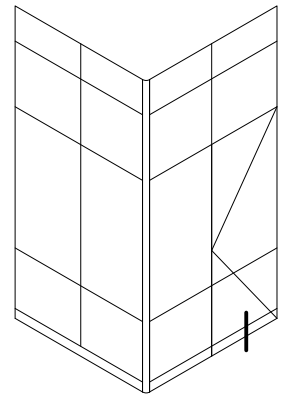
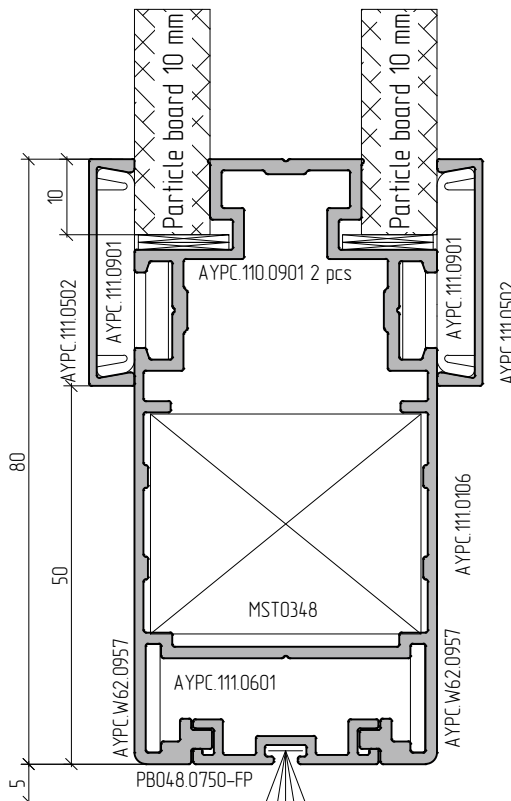
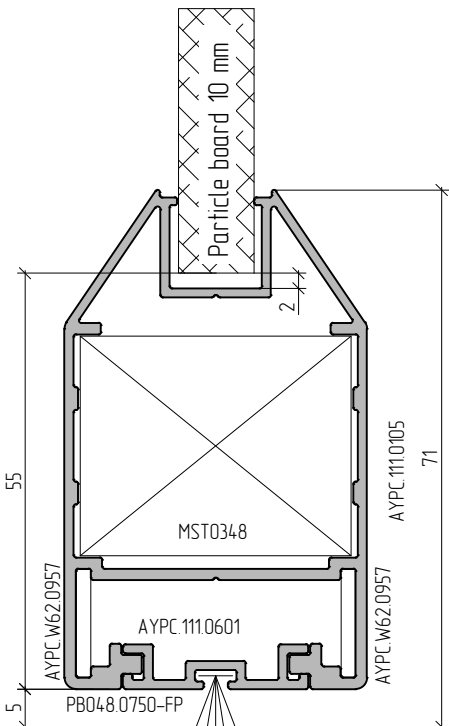
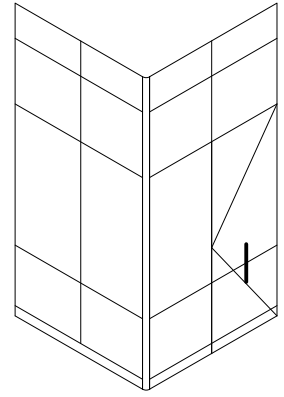
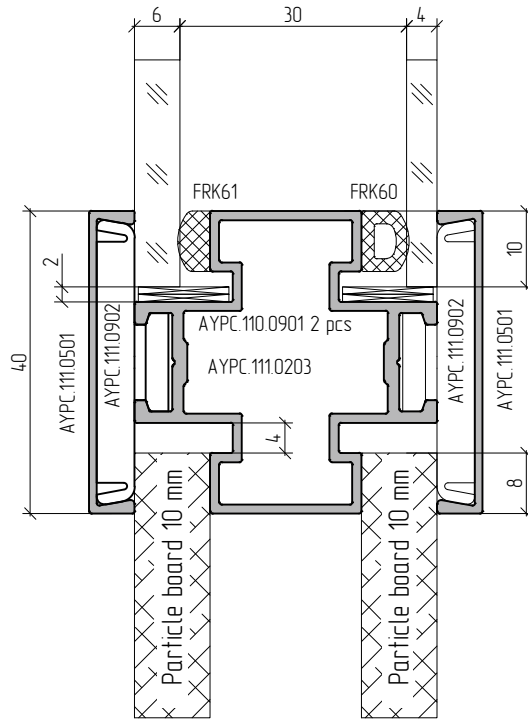
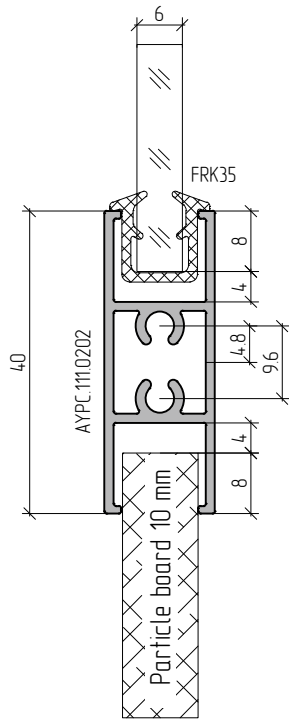

Finish floor level

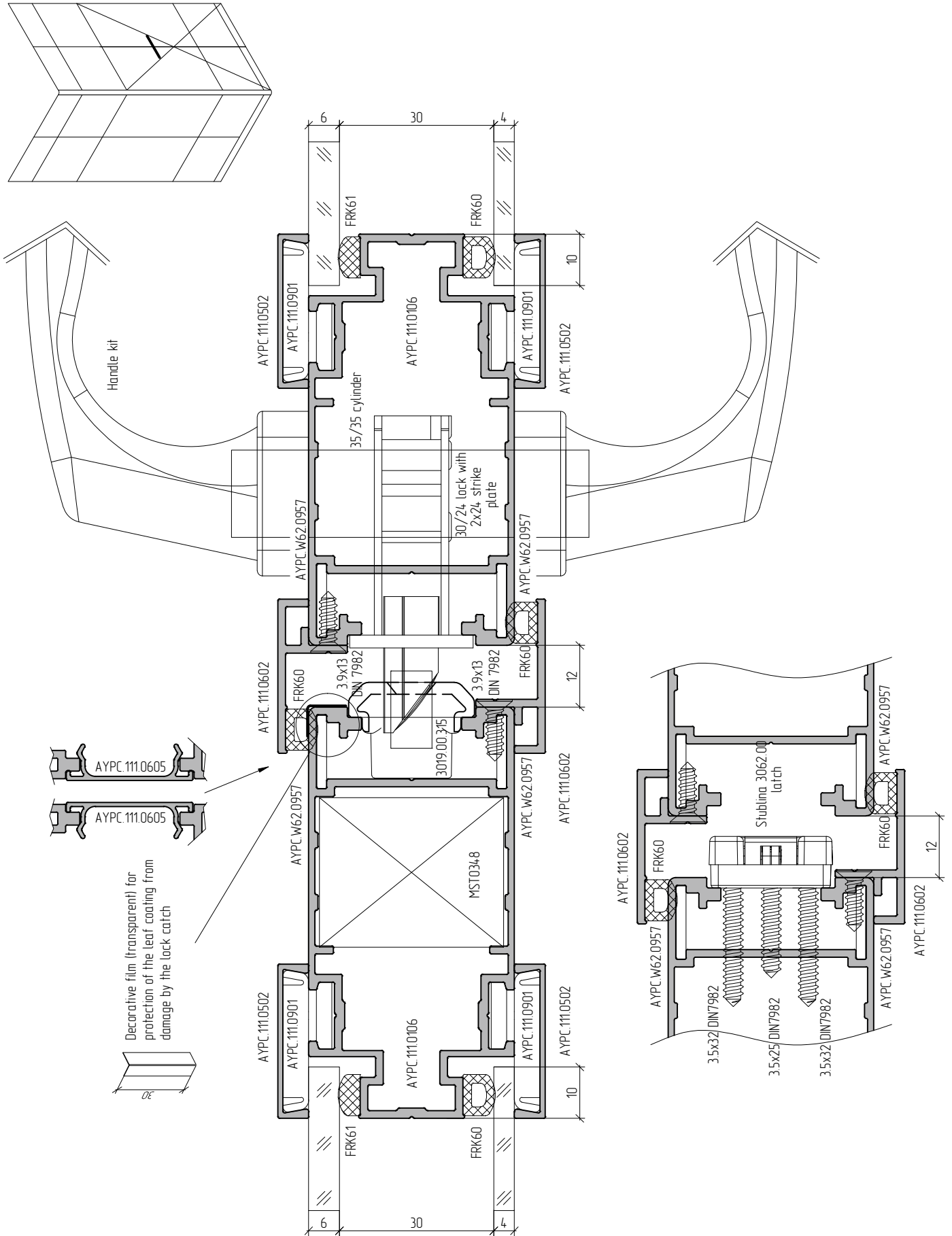

- 01
- 02
- 03
- 04
- 05
- 06
- 07
- 08
- 09
- 10
- 11
- 12
- 13
- 14

Double door. Coupling profile installation

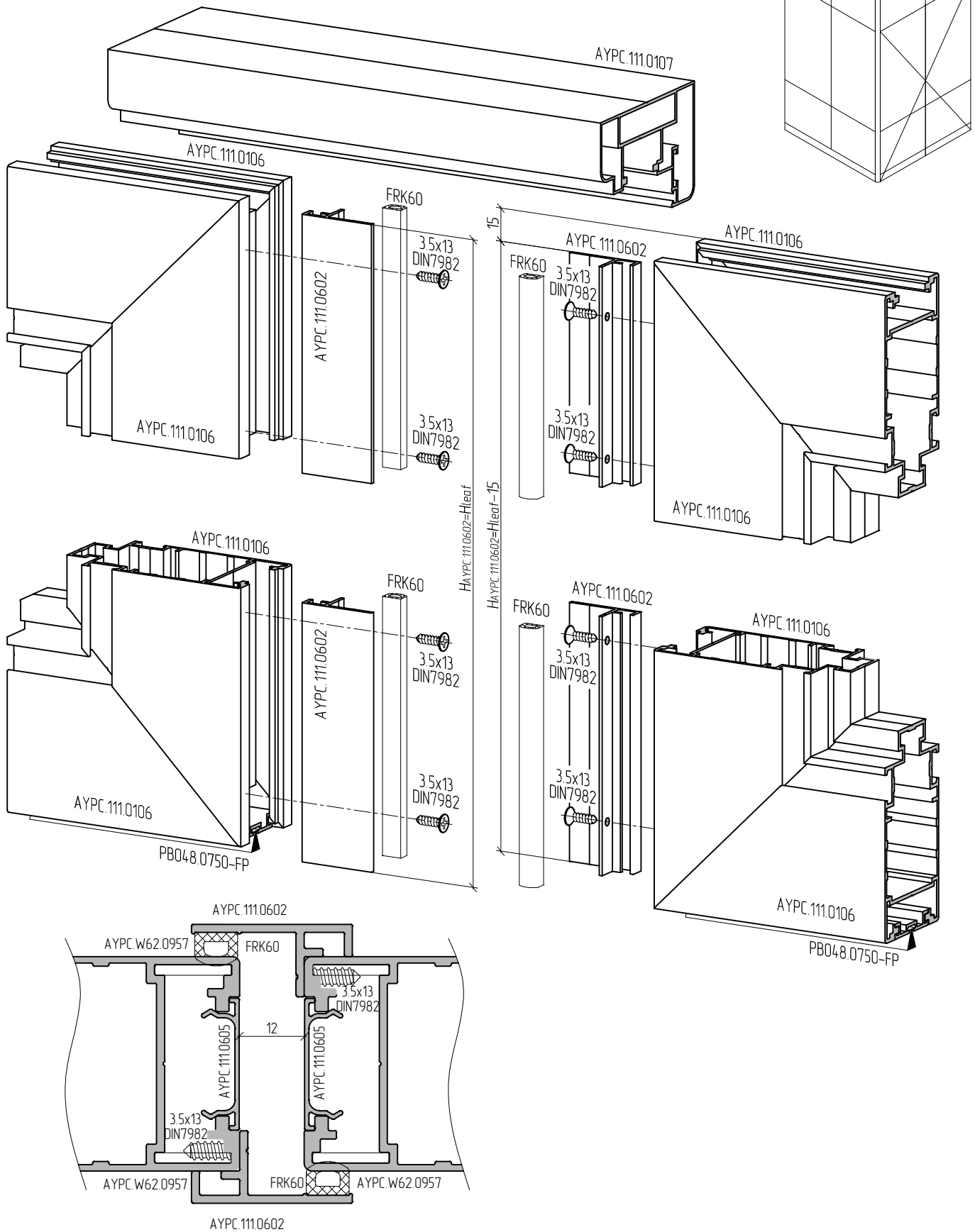

Passive leaf. Upper joint. Latch installation

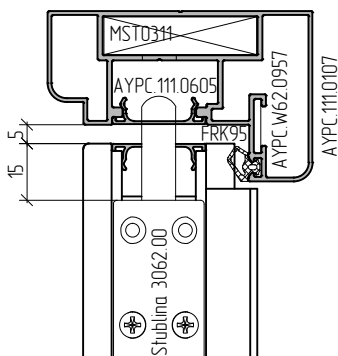
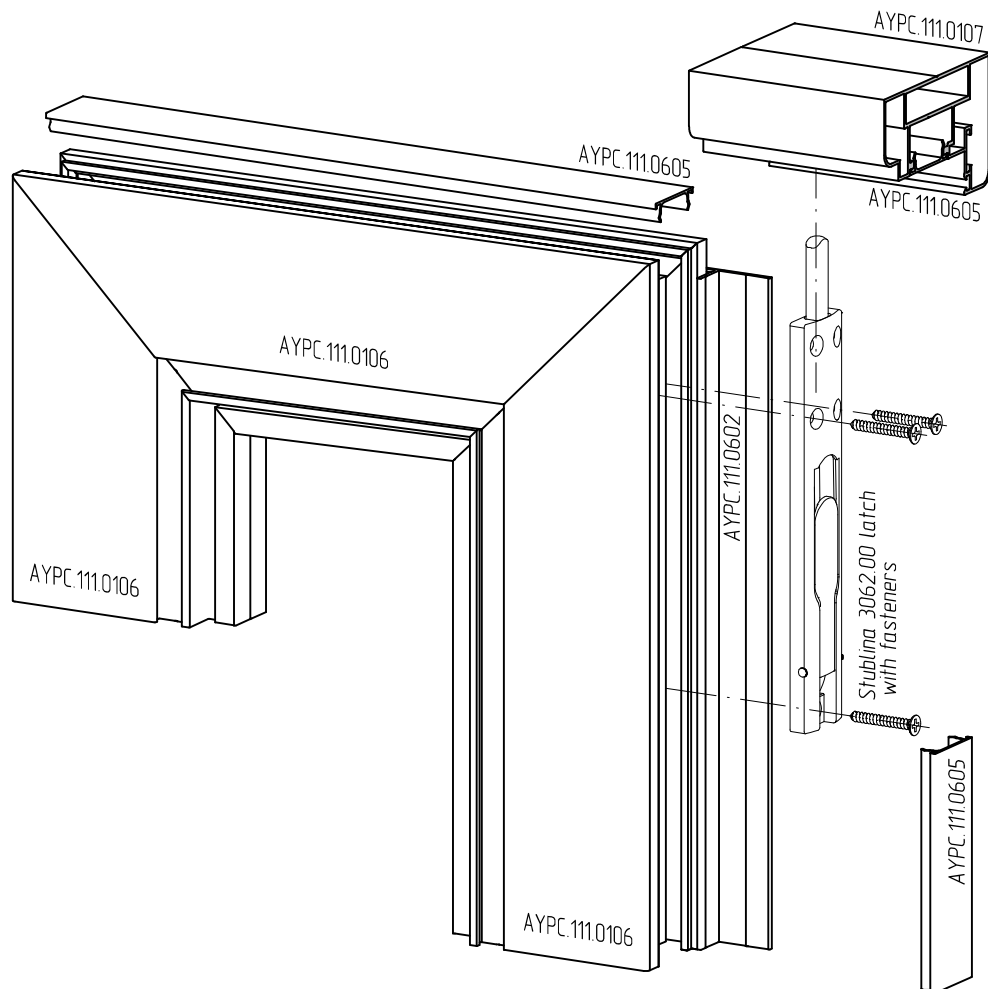
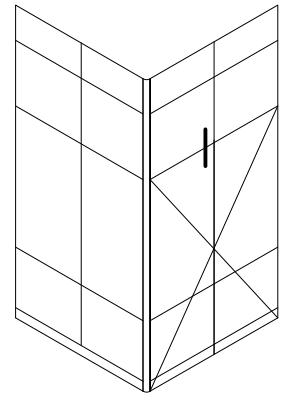

Make a hole in AYPC.111.0605 cover during installation. Fix the latch with 3 screws as shown on the drawing.



Passive leaf. Bottom joint. Latch installation

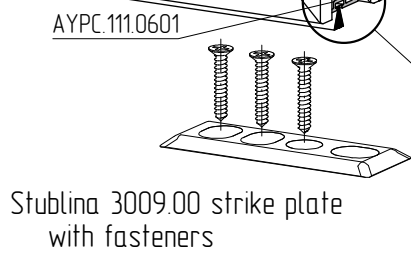
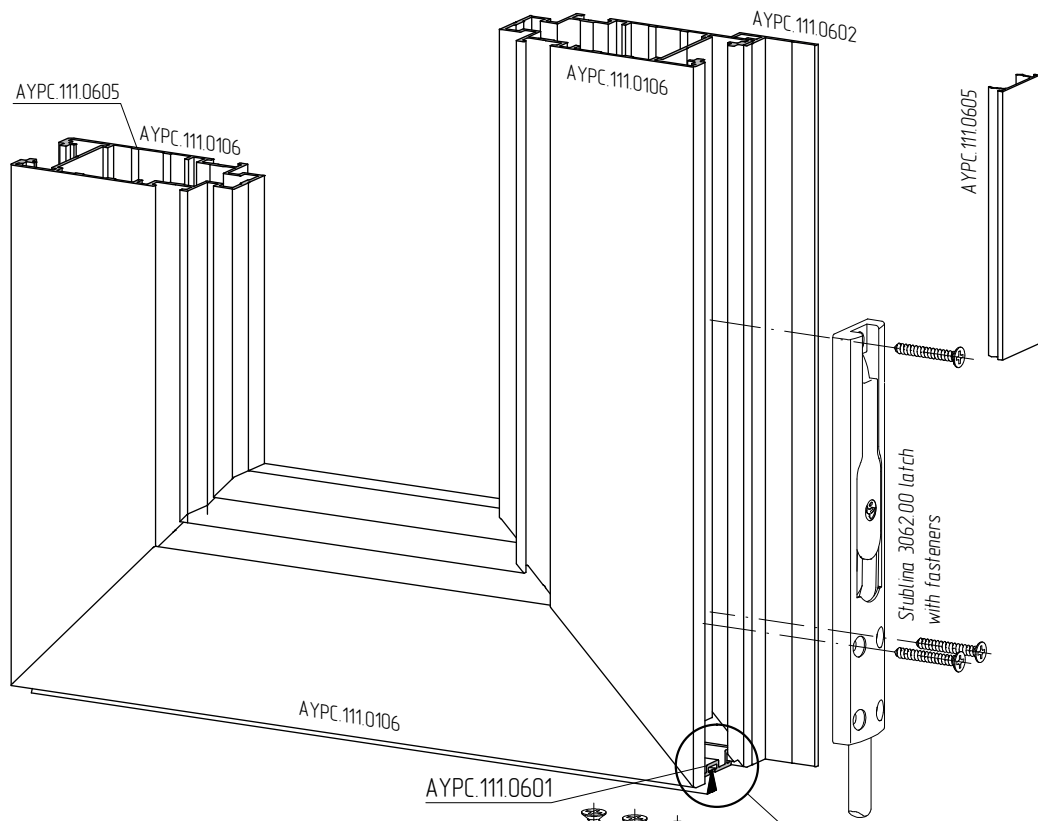
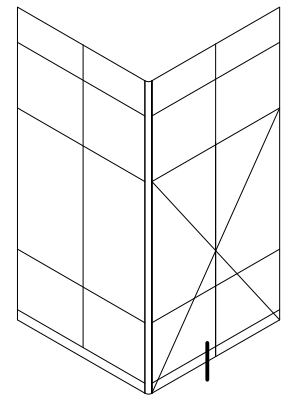

Pay attention to AYPC.111.0601 installation steps

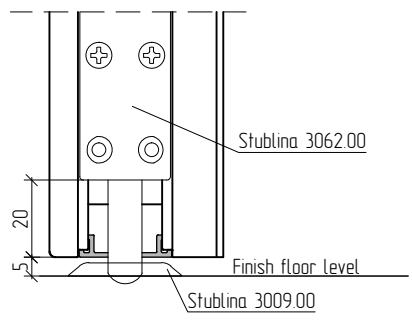
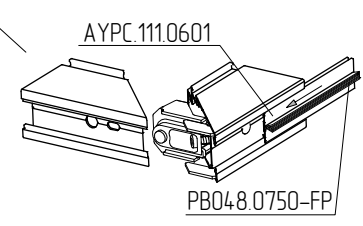

Fix the latch with 3 screws as shown on the drawing.

Hinge installation

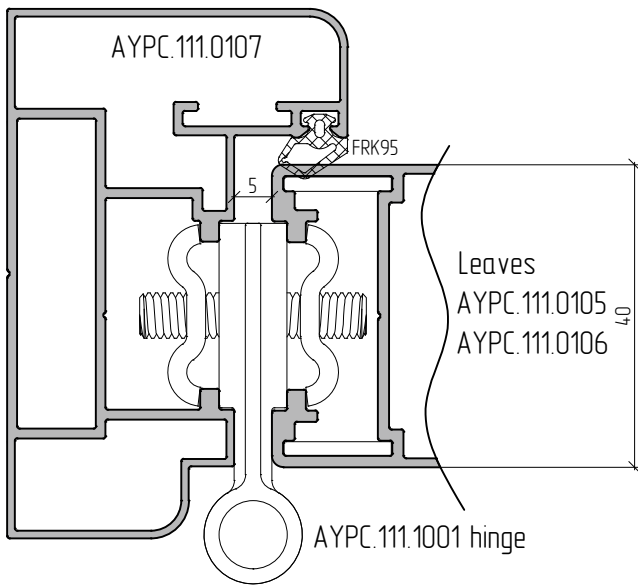

Article	Qty of hinges, pcs	Max. leaf weight, kg	
		Without door closer	With door closer
AYPC.111.1001	2	60	42
	3	70	49
AYPC.111.1006	2	85	59
	3	115	80

Hinges positioning

Two hinges

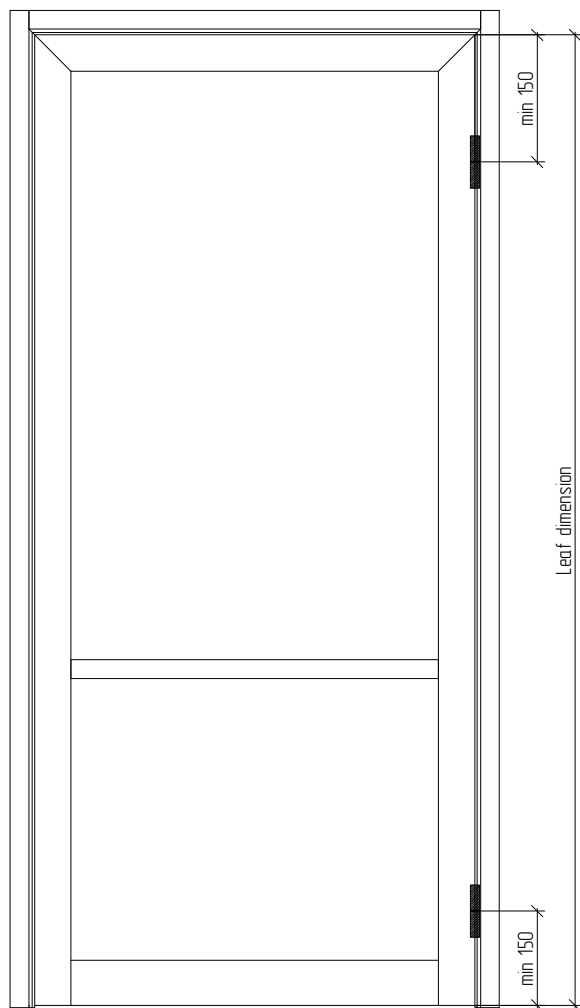

Three hinges

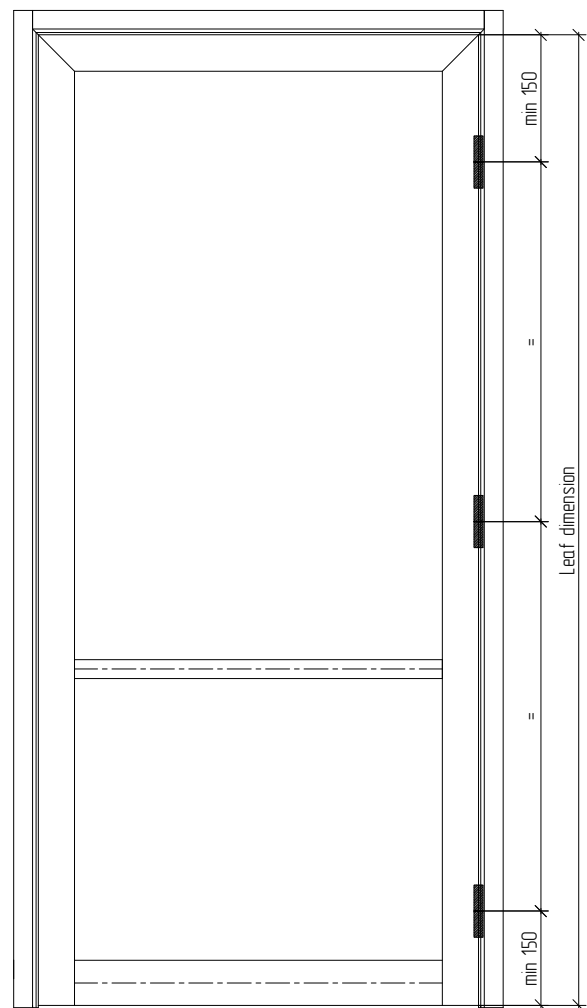

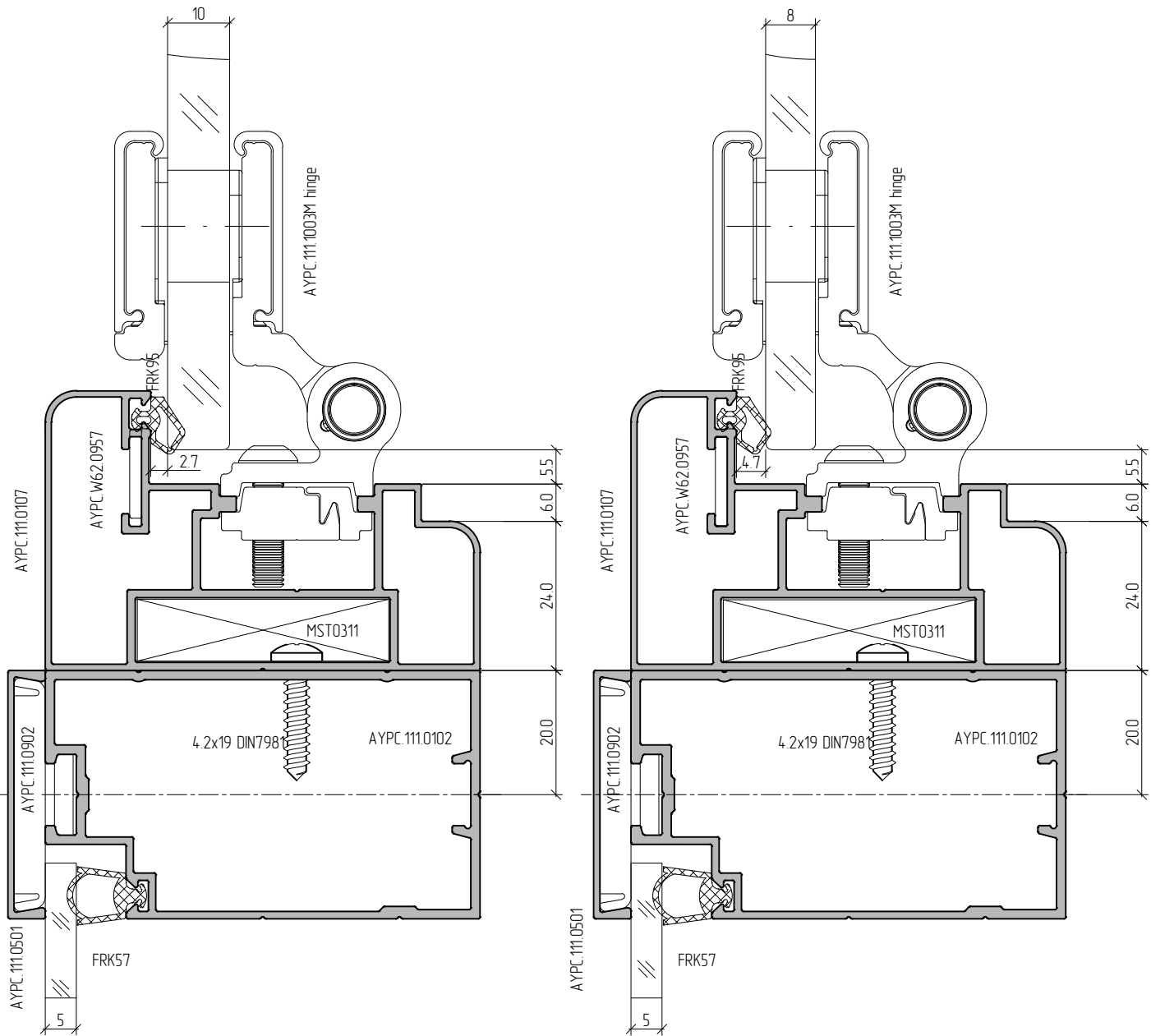
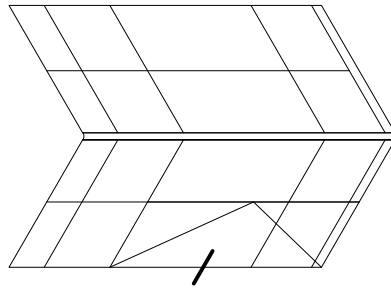

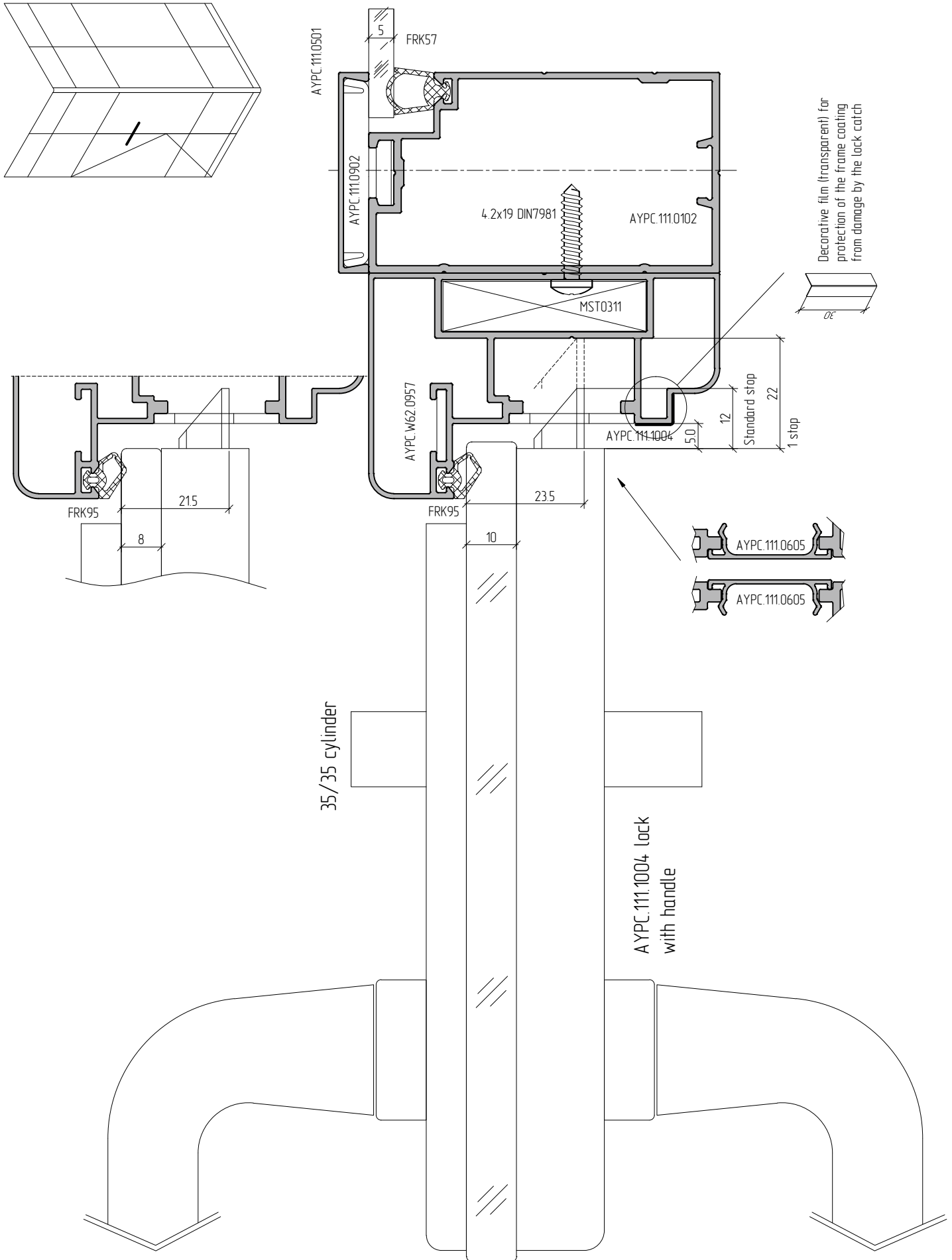

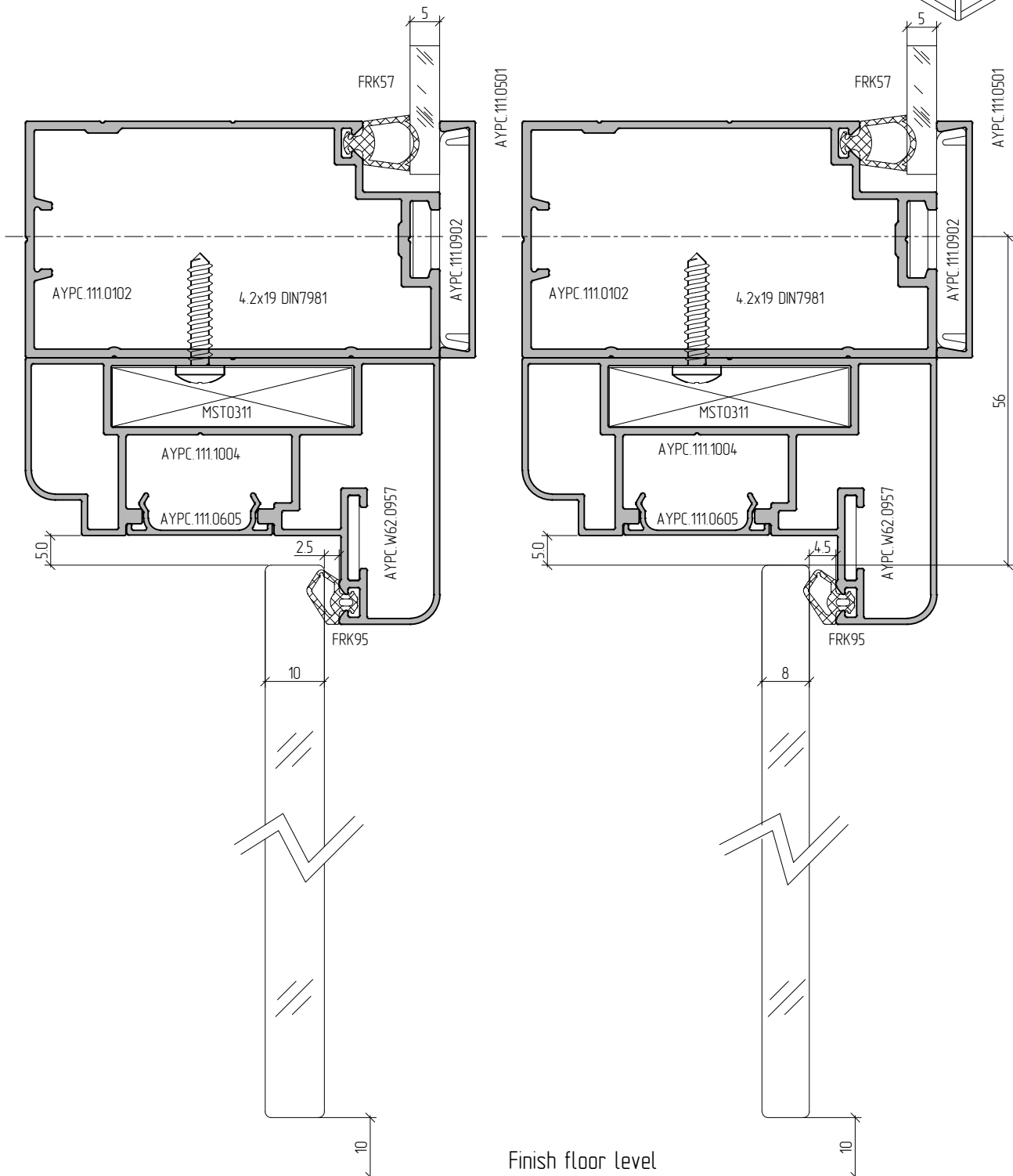
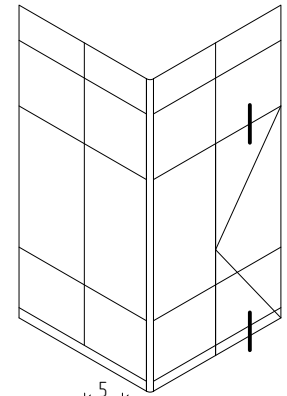

Door leaf glass processing for AYPC.111.1003M hinge installation

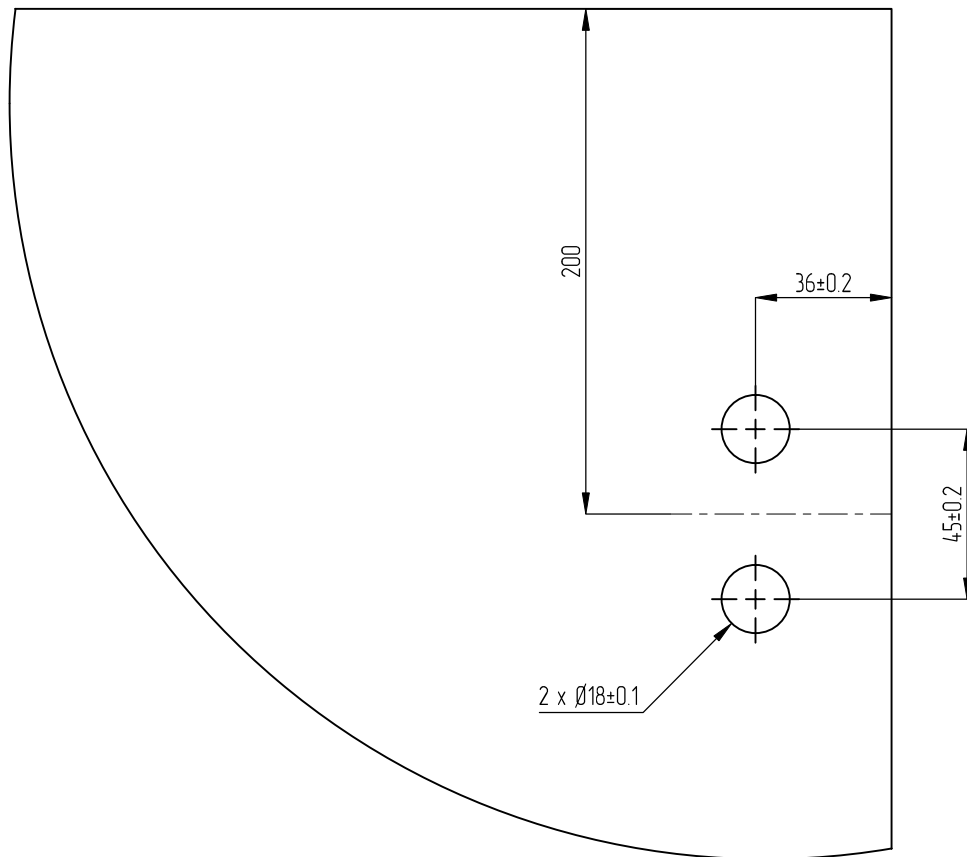

Door leaf glass processing for AYPC.111.1004 lock installation

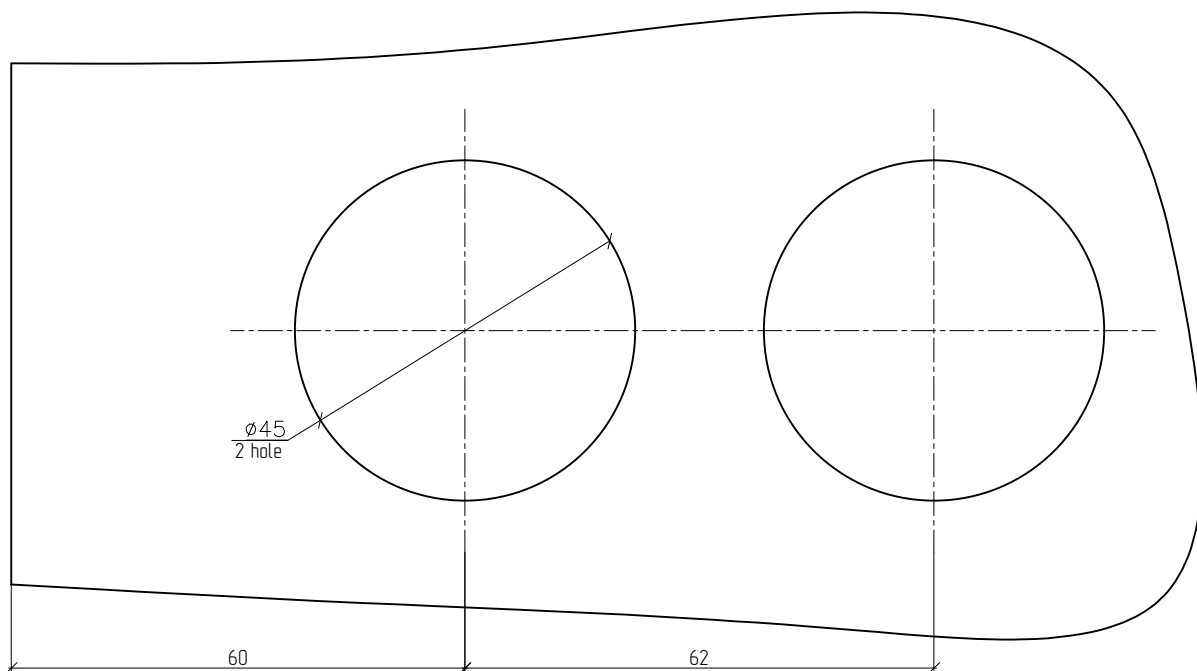

All-glass leaf installation using AYPC.111.1003M hinges

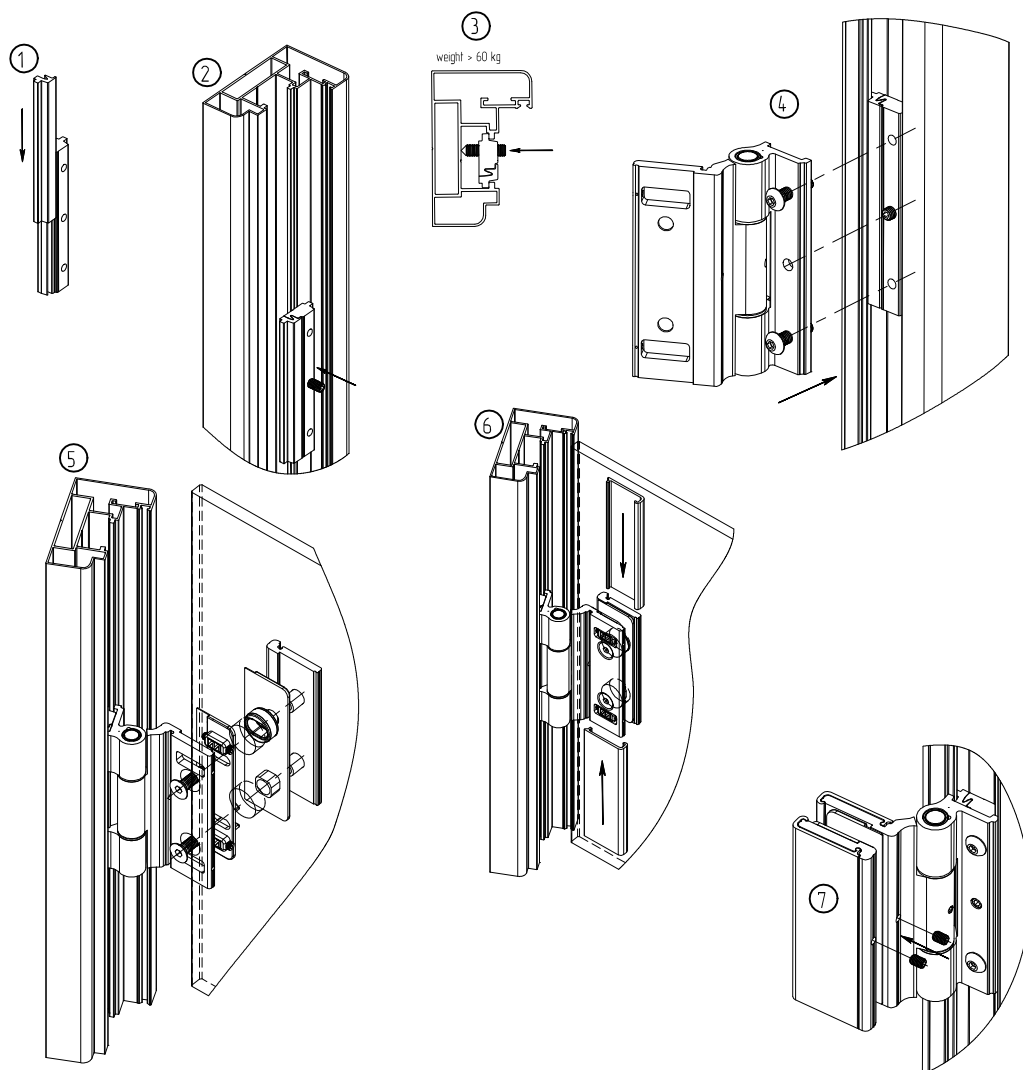

Strike plate drawing for AYPC.111.1004 lock (strike plate is supplied in the same kit with lock)  
Material – steel 12X17 DIN 1.4016

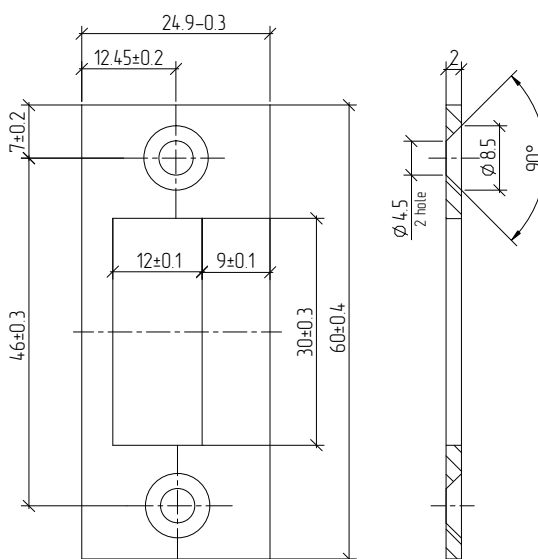

Hinges positioning

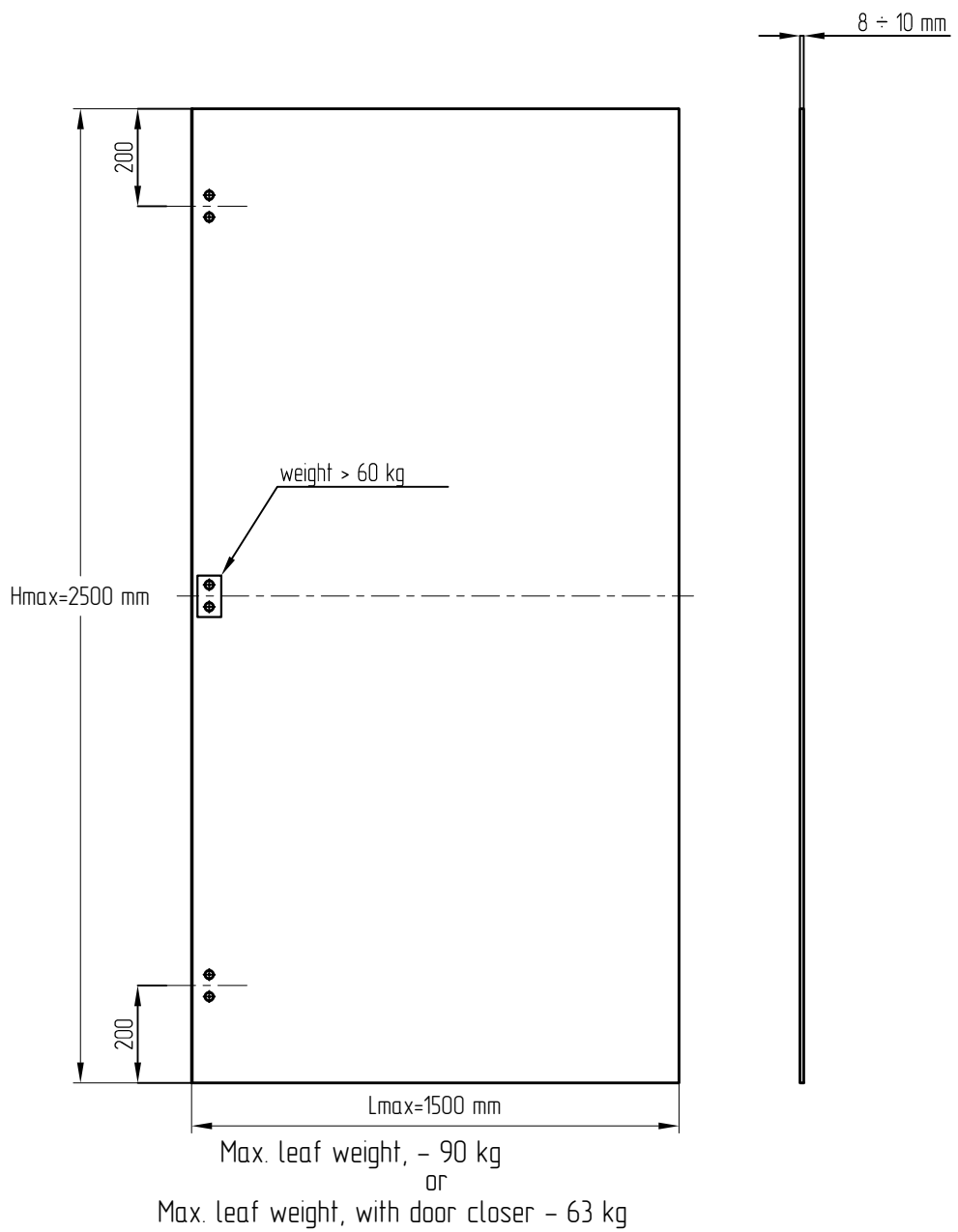
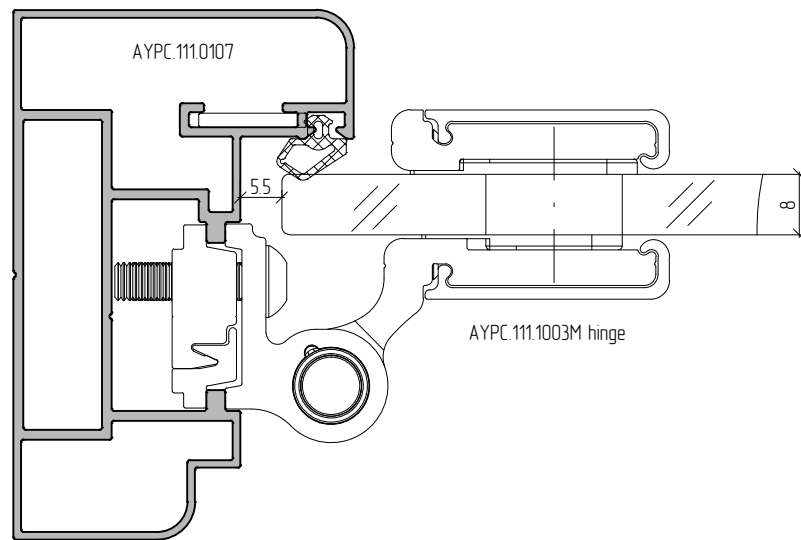



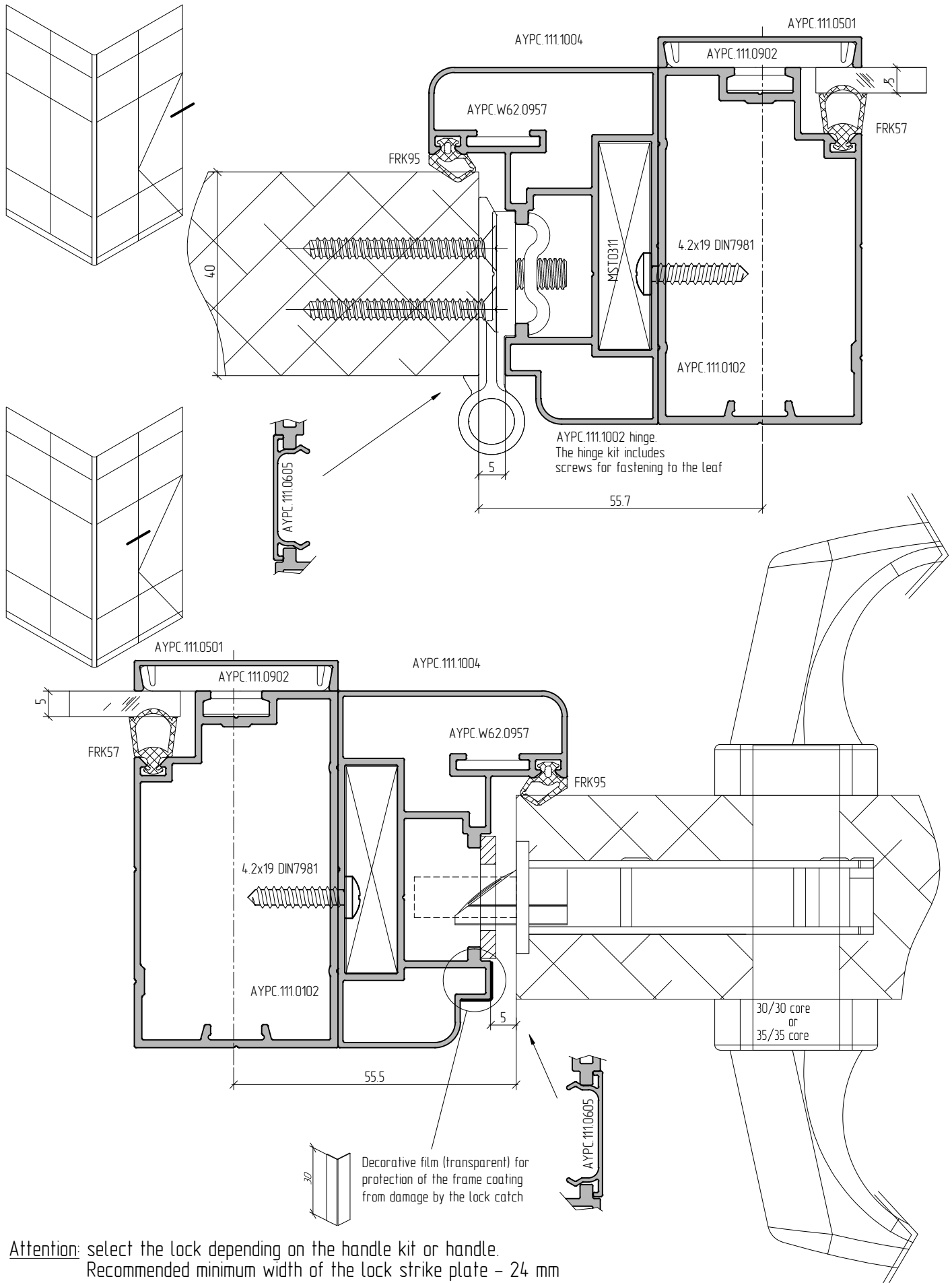

Attention: select the lock depending on the handle kit or handle.  
Recommended minimum width of the lock strike plate - 24 mm

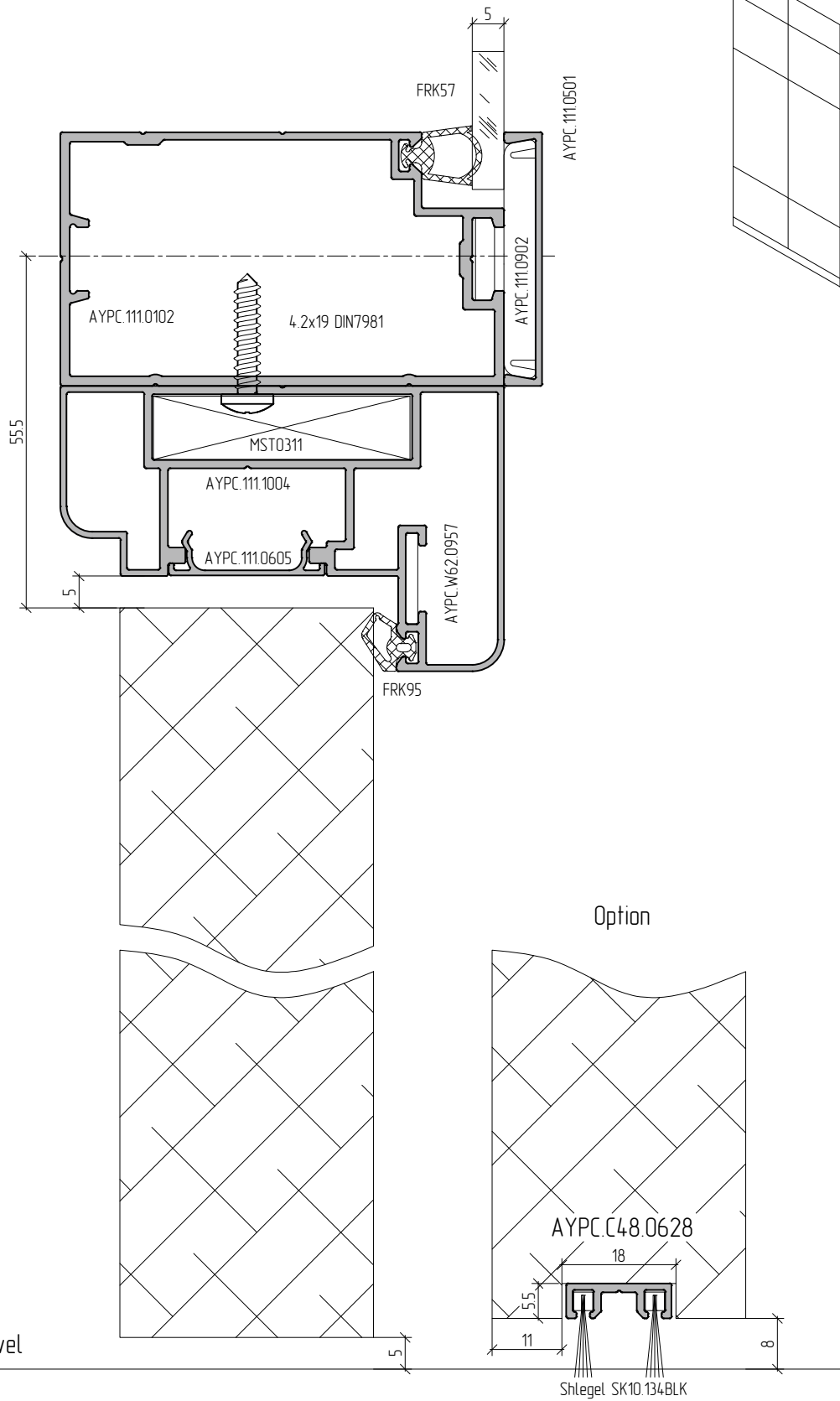

Hinge installation

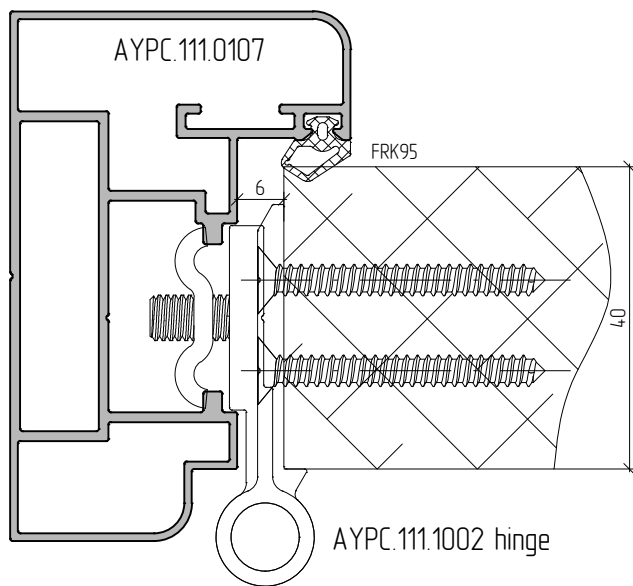

Hinges positioning

Two hinges

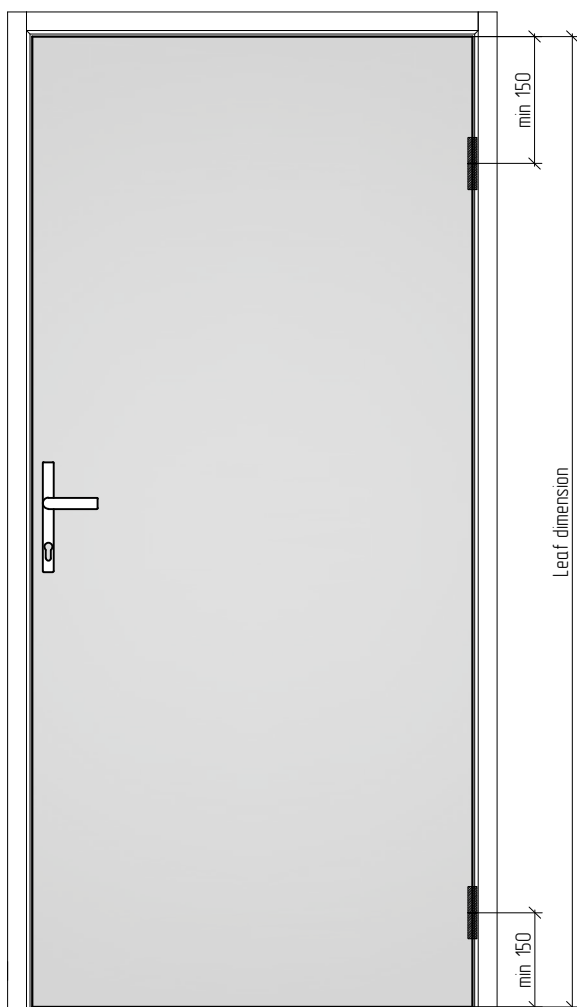

Three hinges

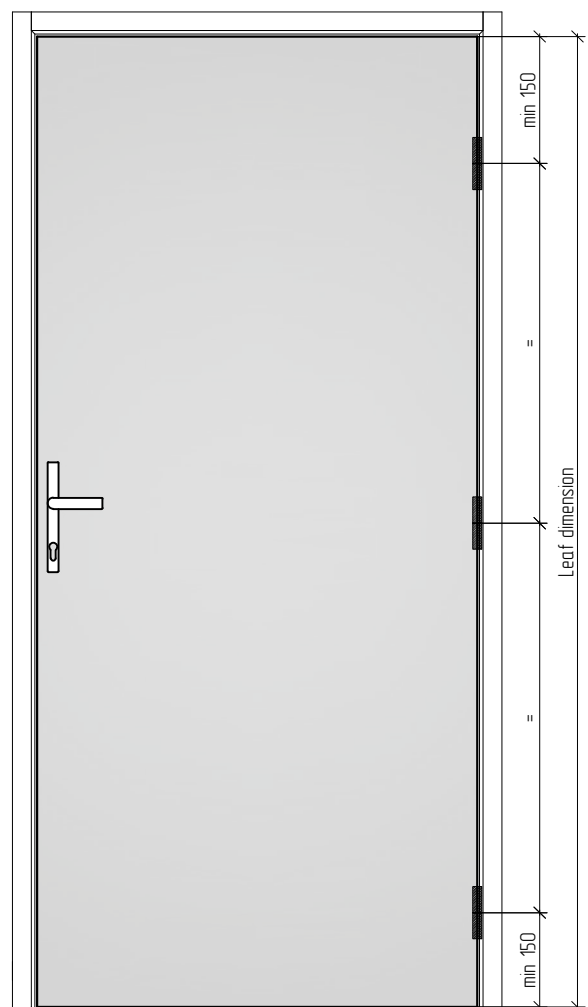

Double leaf door. Double casement profile installation

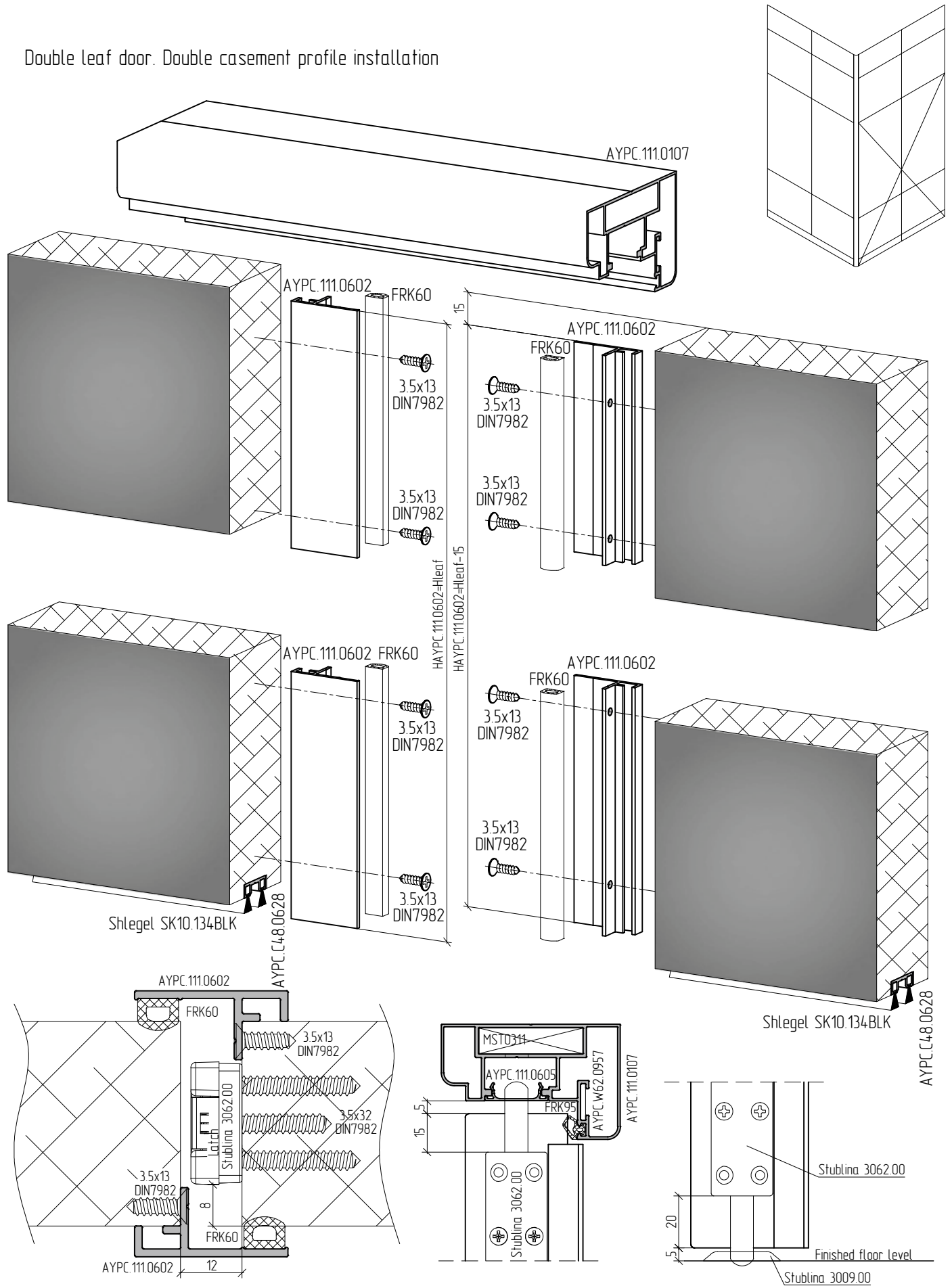

## Standard single-glazed door

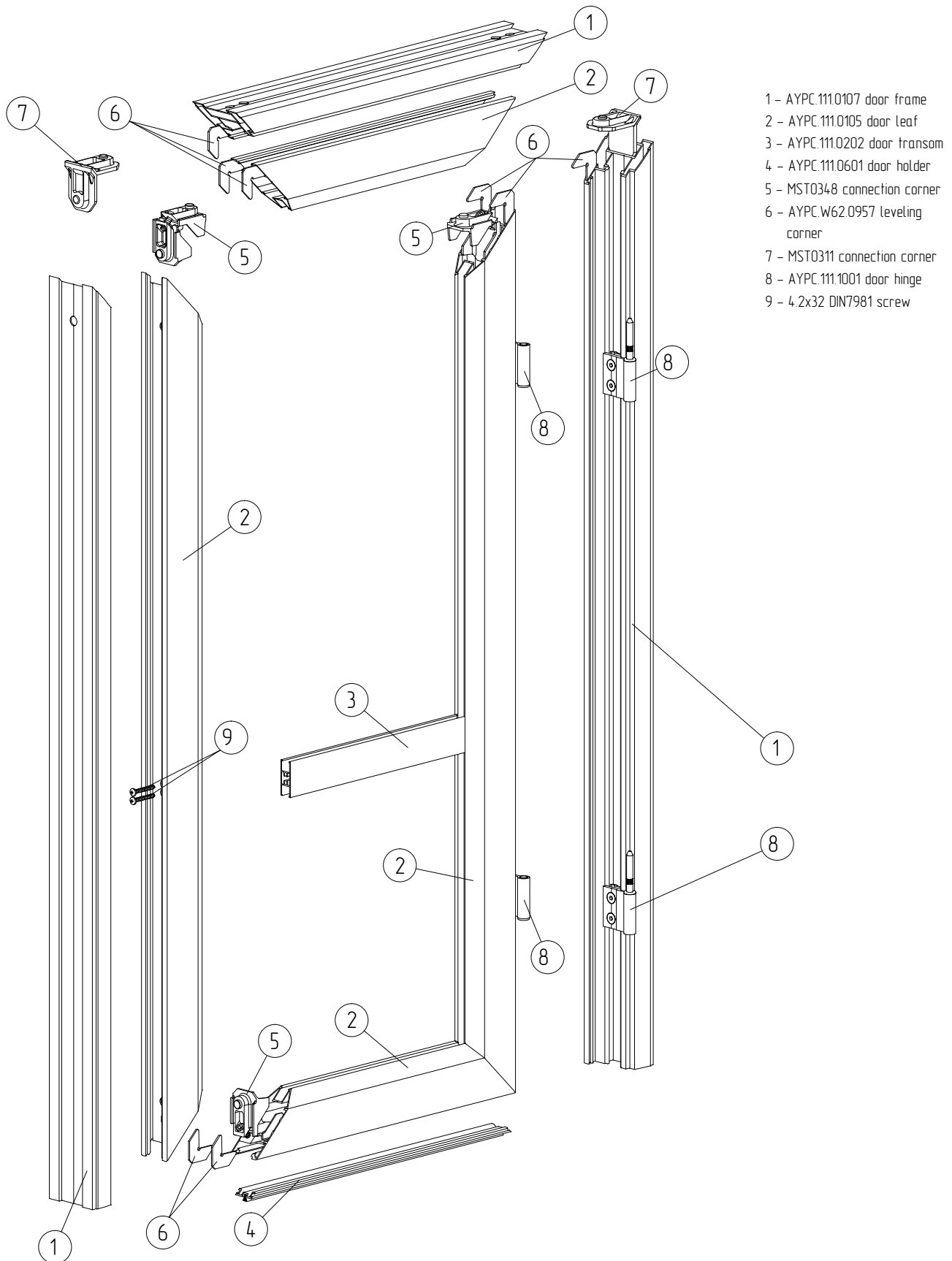

Standard double-glazed door

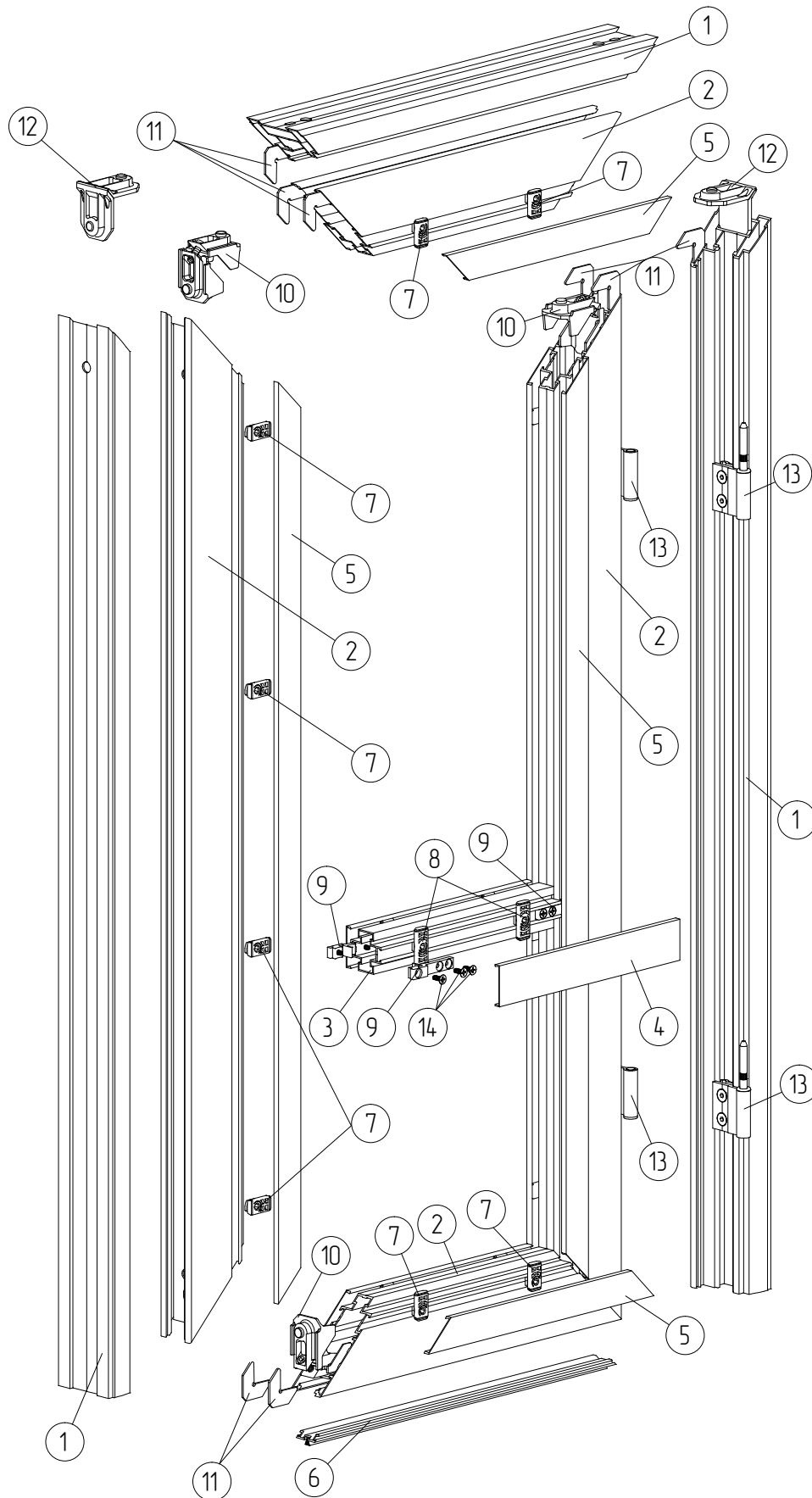

- 1 - AYPC.111.0107 door frame
- 2 - AYPC.111.0106 door leaf
- 3 - AYPC.111.0203 door transom
- 4 - AYPC.111.0501 cover profile
- 5 - AYPC.111.0502 cover profile
- 6 - AYPC.111.0601 door holder
- 7 - AYPC.111.0901 clamp
- 8 - AYPC.111.0902 clamp
- 9 - AYPC.111.0952 bracket
- 10 - MST0348 connection corner
- 11 - AYPC.W62.0957 leveling corner
- 12 - MST0311 connection corner
- 13 - AYPC.111.1001 door hinge
- 14 - 4.2x13 DIN7982 self-tapping screw

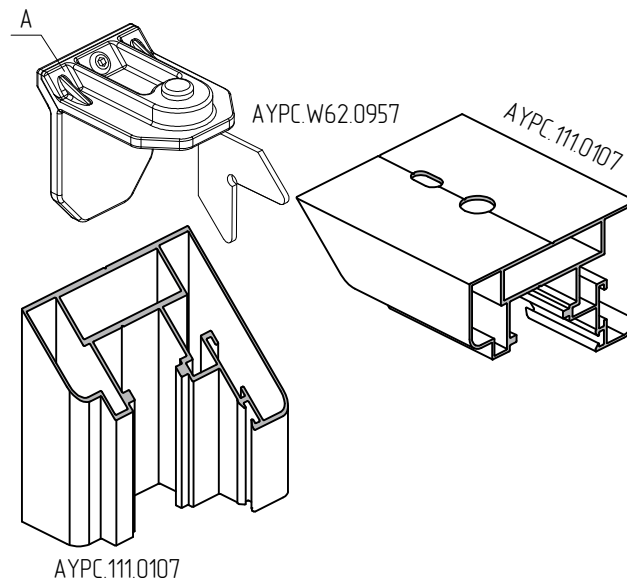

As corner connector A it is possible to use:  
 MST0311 40.5x9.9 mm corner (manufactured by Master);  
 MON0373 39.4x9.9 mm corner (manufactured by Monticelli).

option for MST0311 corner installation

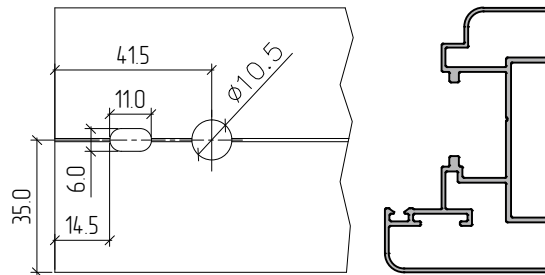

option for MON0373 corner installation

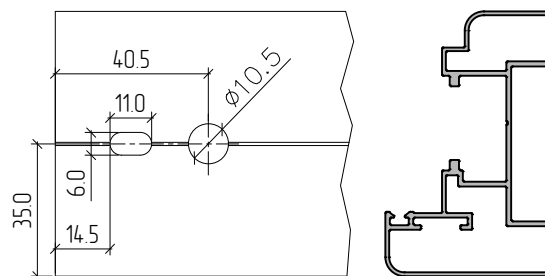

AYPC.111.0105 and AYPC.111.0106 leaf profile corner connection

AYPC.W62.0957

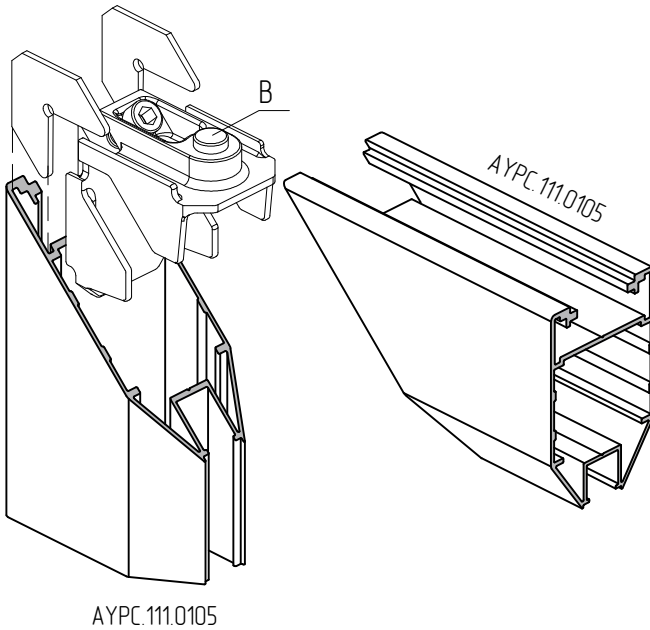

AYPC.111.0105

AYPC.W62.0957

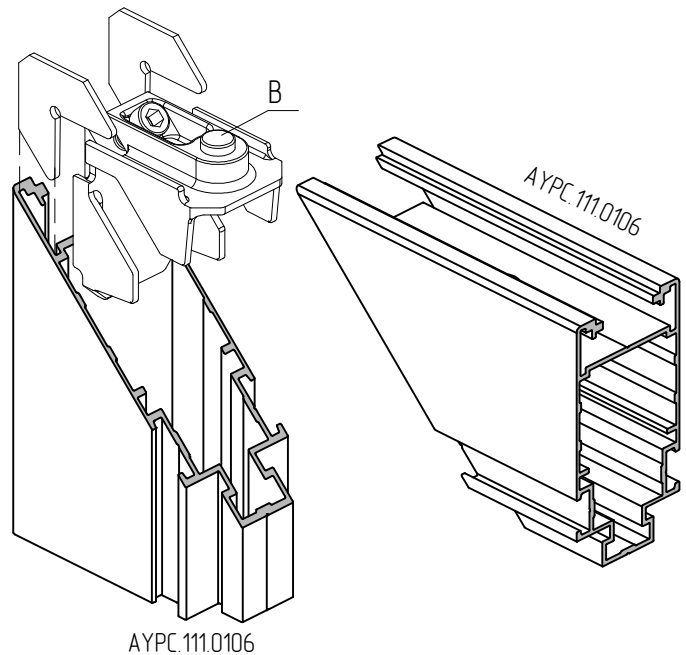

AYPC.111.0106

As corner connector B  
it is possible to use:

MST0348 35.8x30.5 mm corner (manufactured by Master);

MON0406 35.9x30.5 mm corner (manufactured by Monticelli).

Attention! Vertical leaf profiles should be processed for further swivel screw installation.

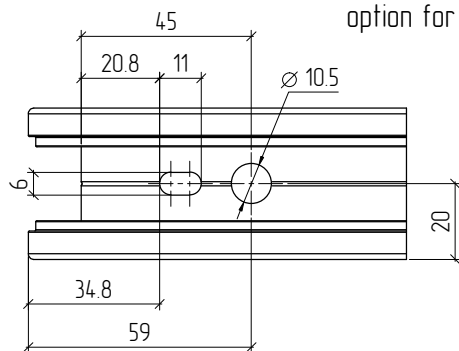

option for MST0348 corner installation

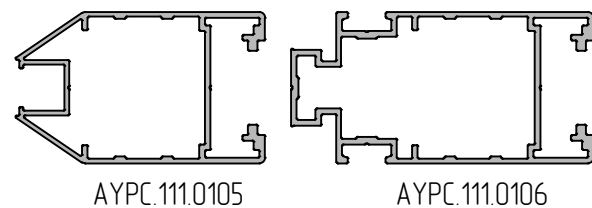

AYPC.111.0105

AYPC.111.0106

option for MON0406 corner installation

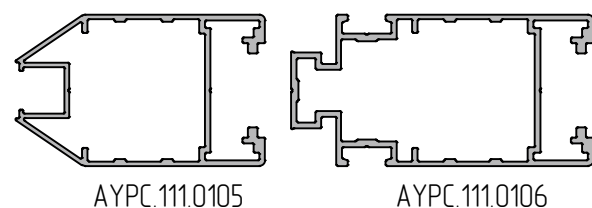
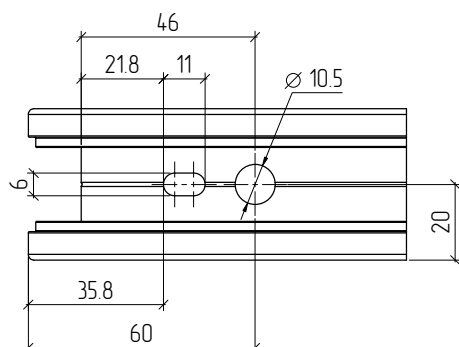

AYPC.111.0105

AYPC.111.0106





AYPC.111.0601 profile installation into AYPC.111.0105 and AYPC.111.0106 leaf profiles

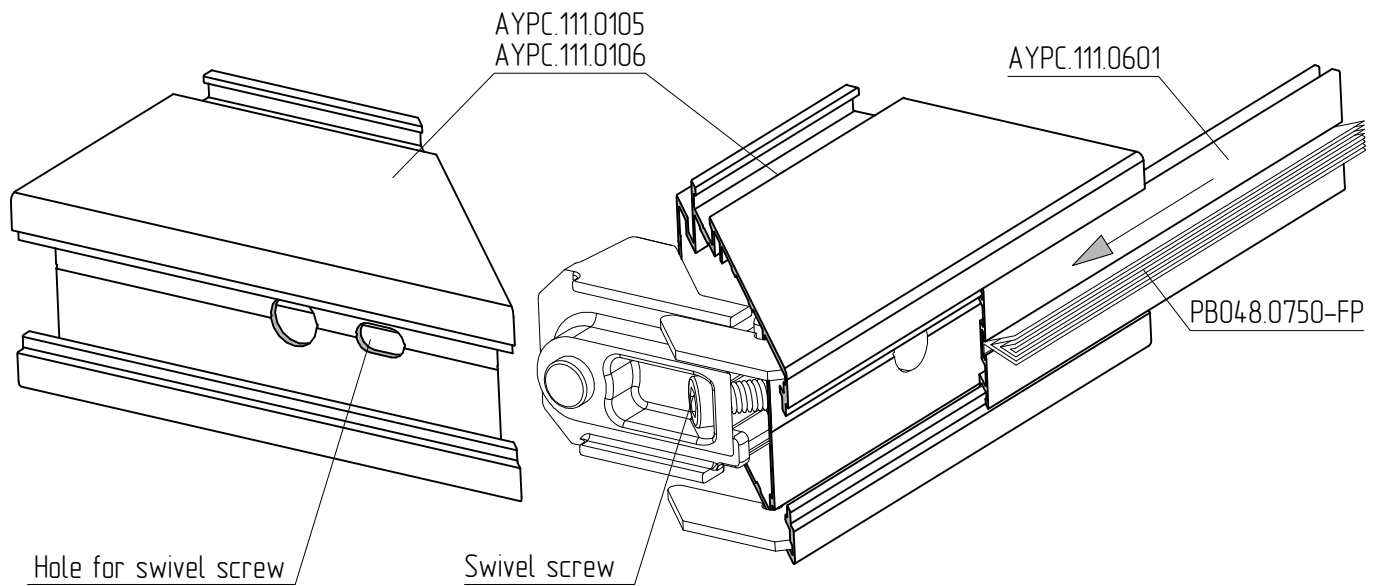

Cut AYPC.111.0601 profile at 45° on the same way as leaf profile, install it into the leaf profile groove in advance.  
The size of AYPC.111.0601 profile is equal to the width of the door leaf.  
Attention! Vertical leaf profiles should be processed for further swivel screw installation.

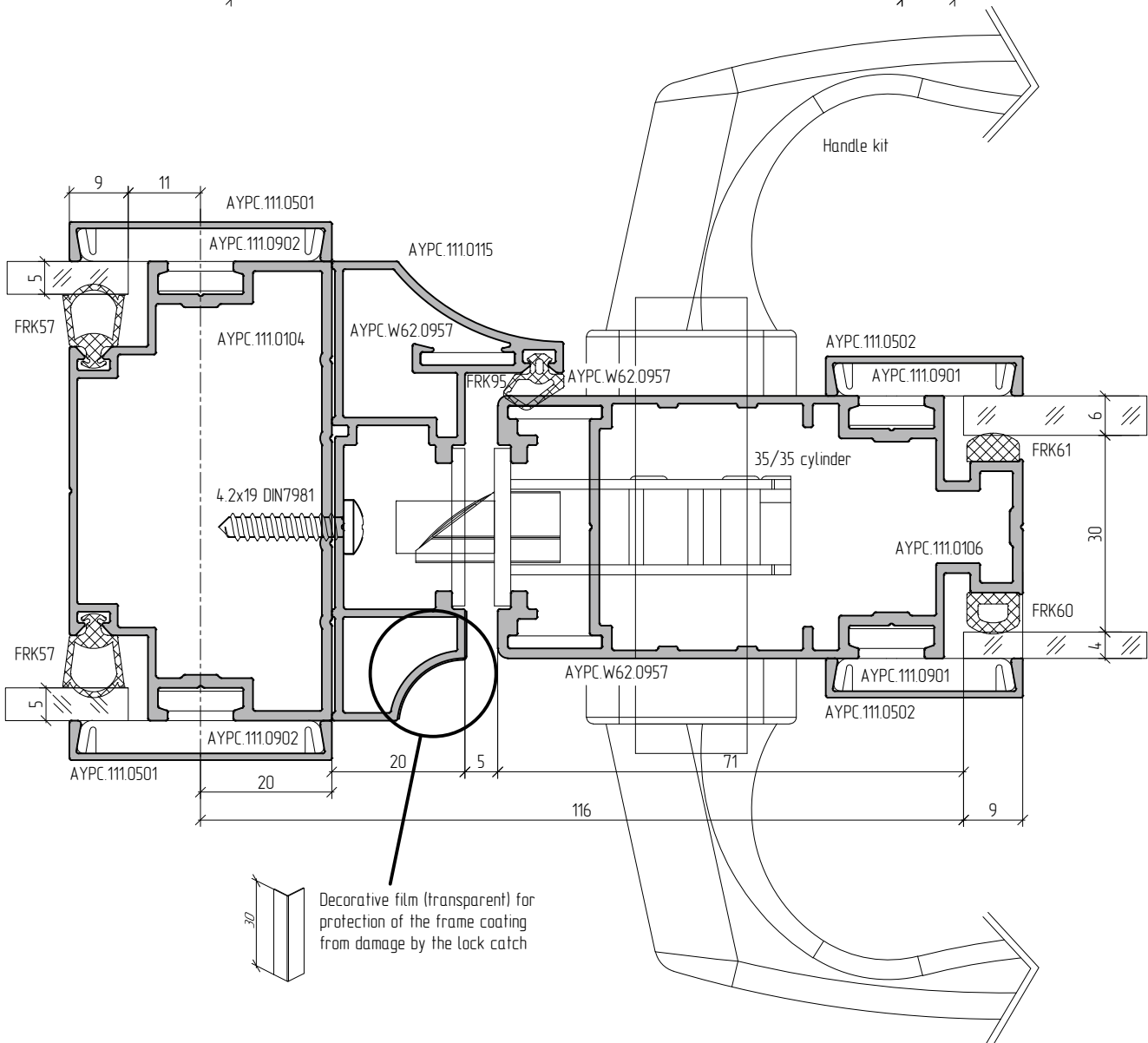
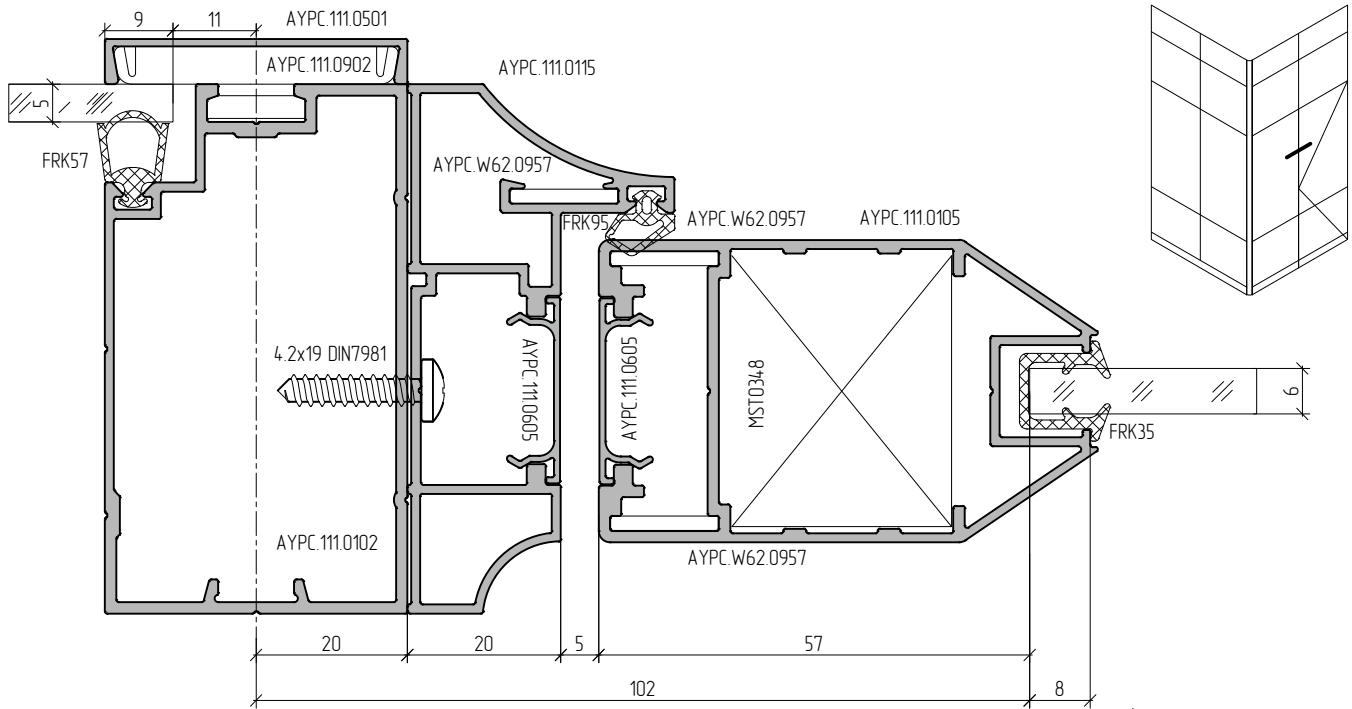

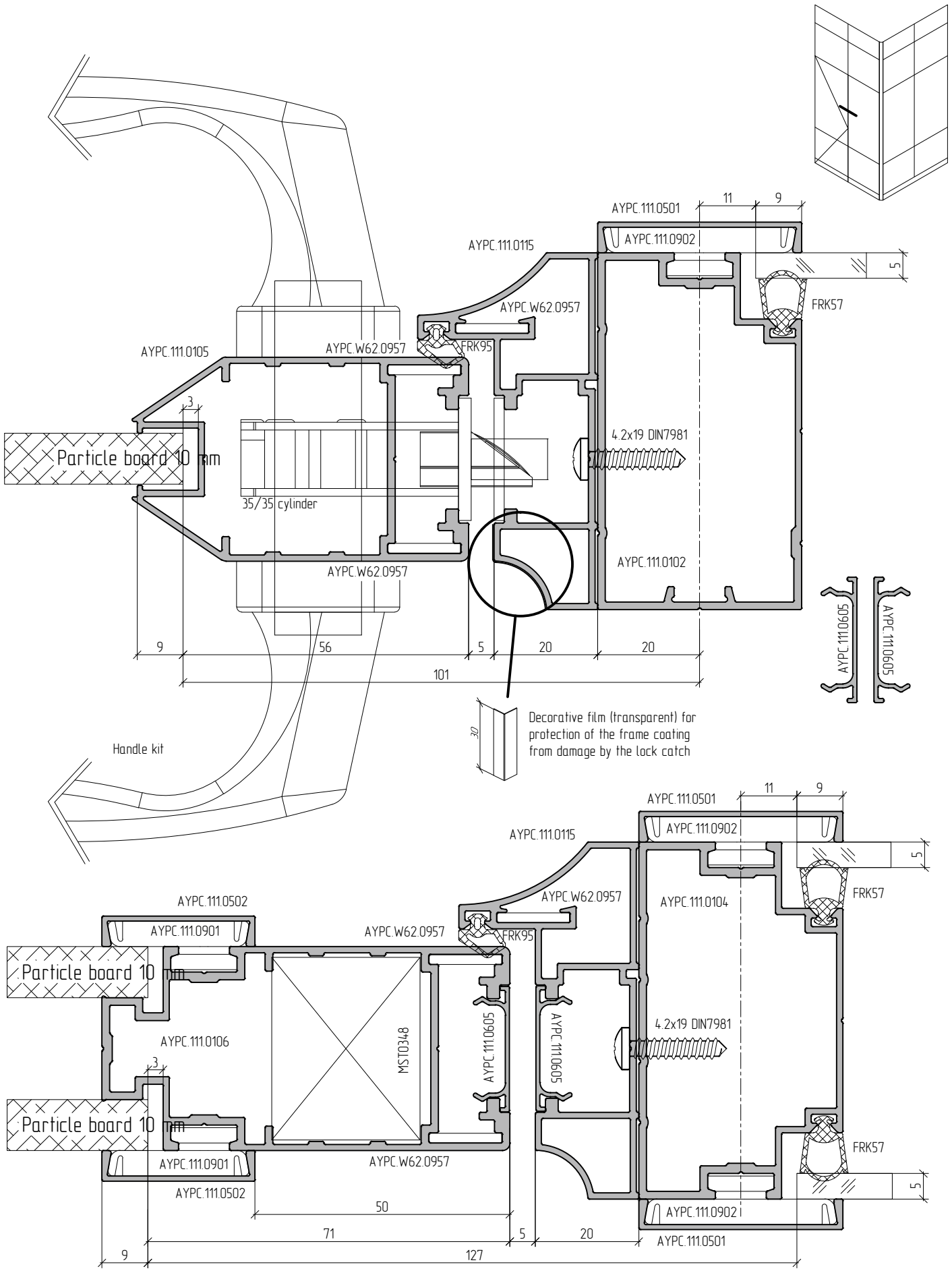

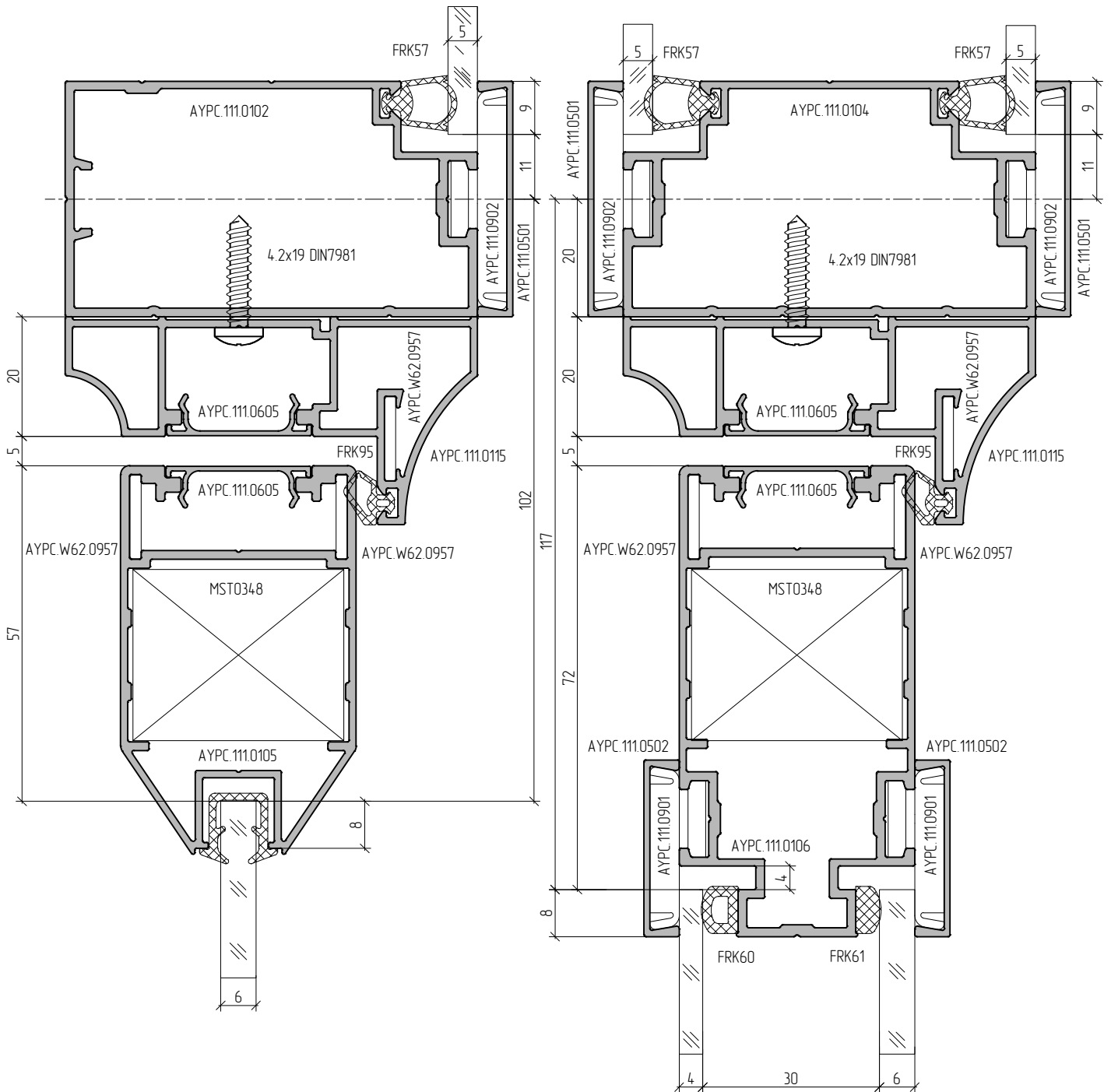
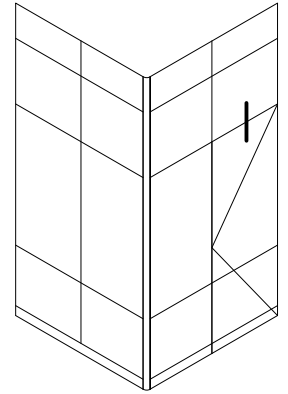

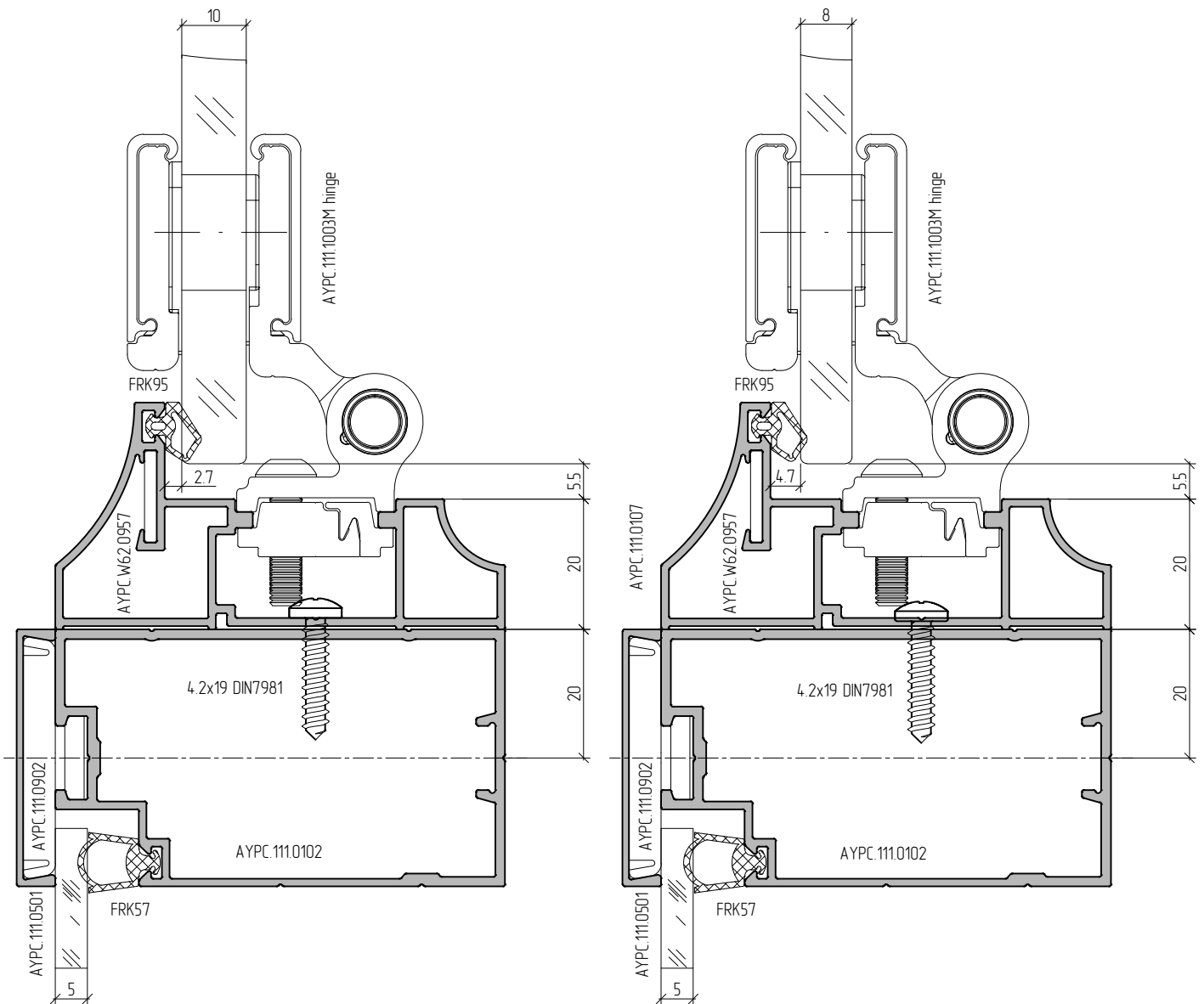
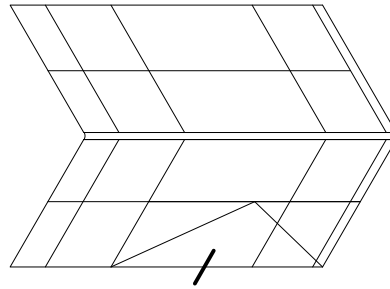

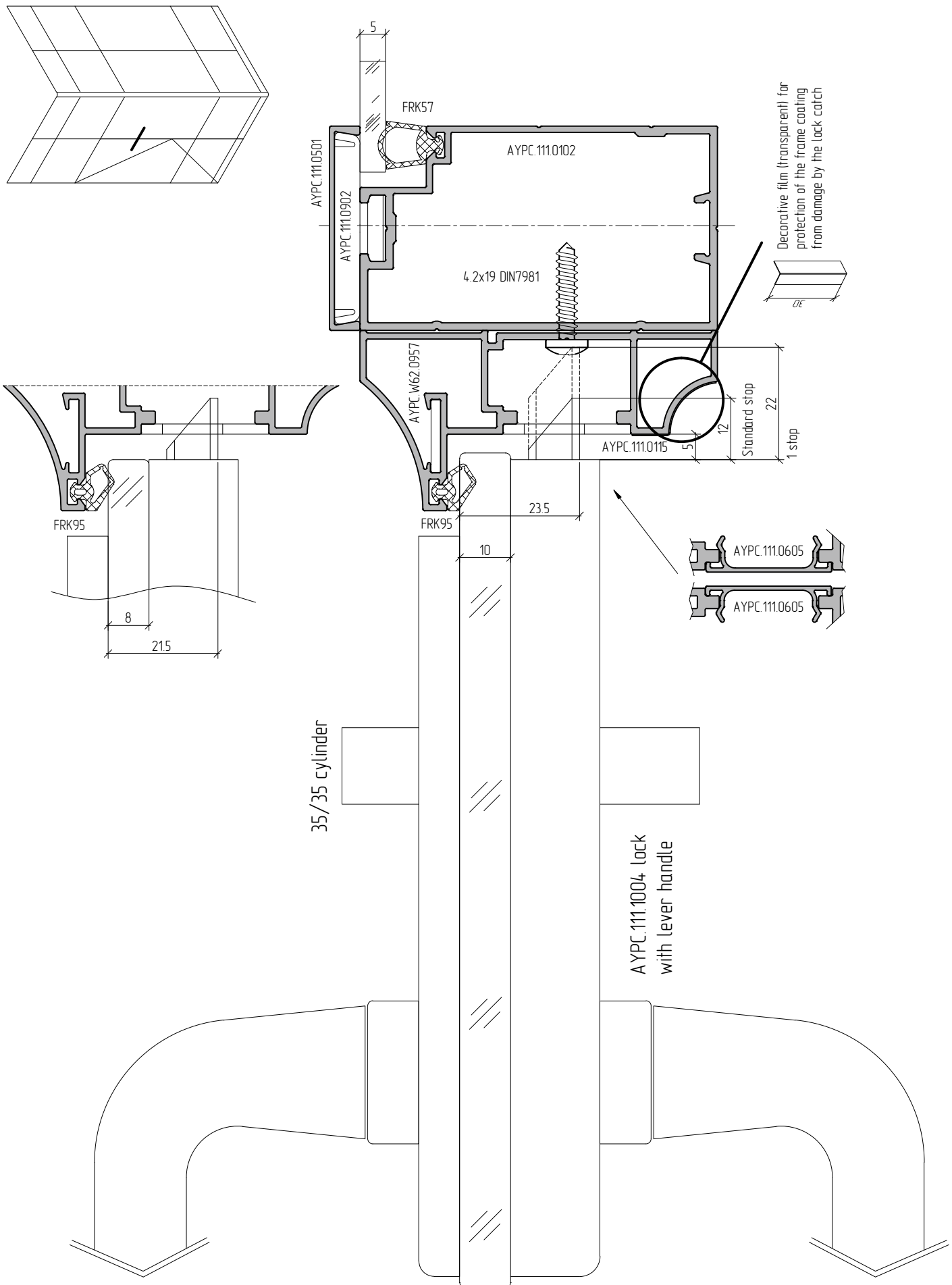

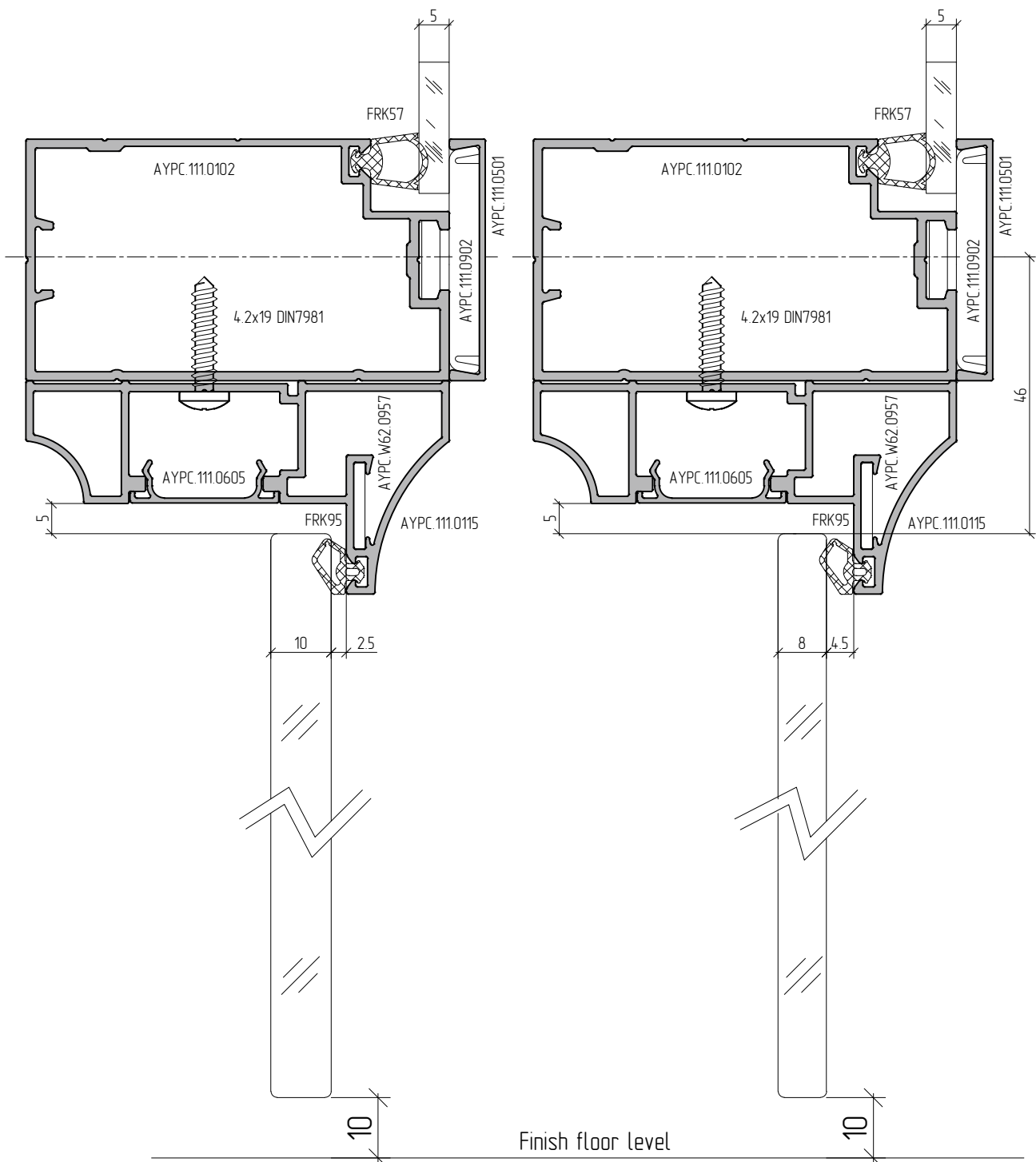
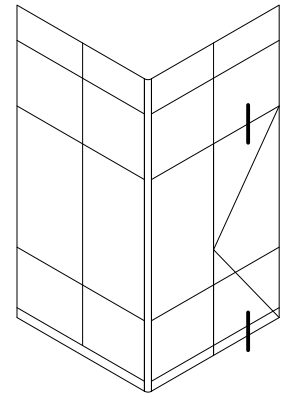



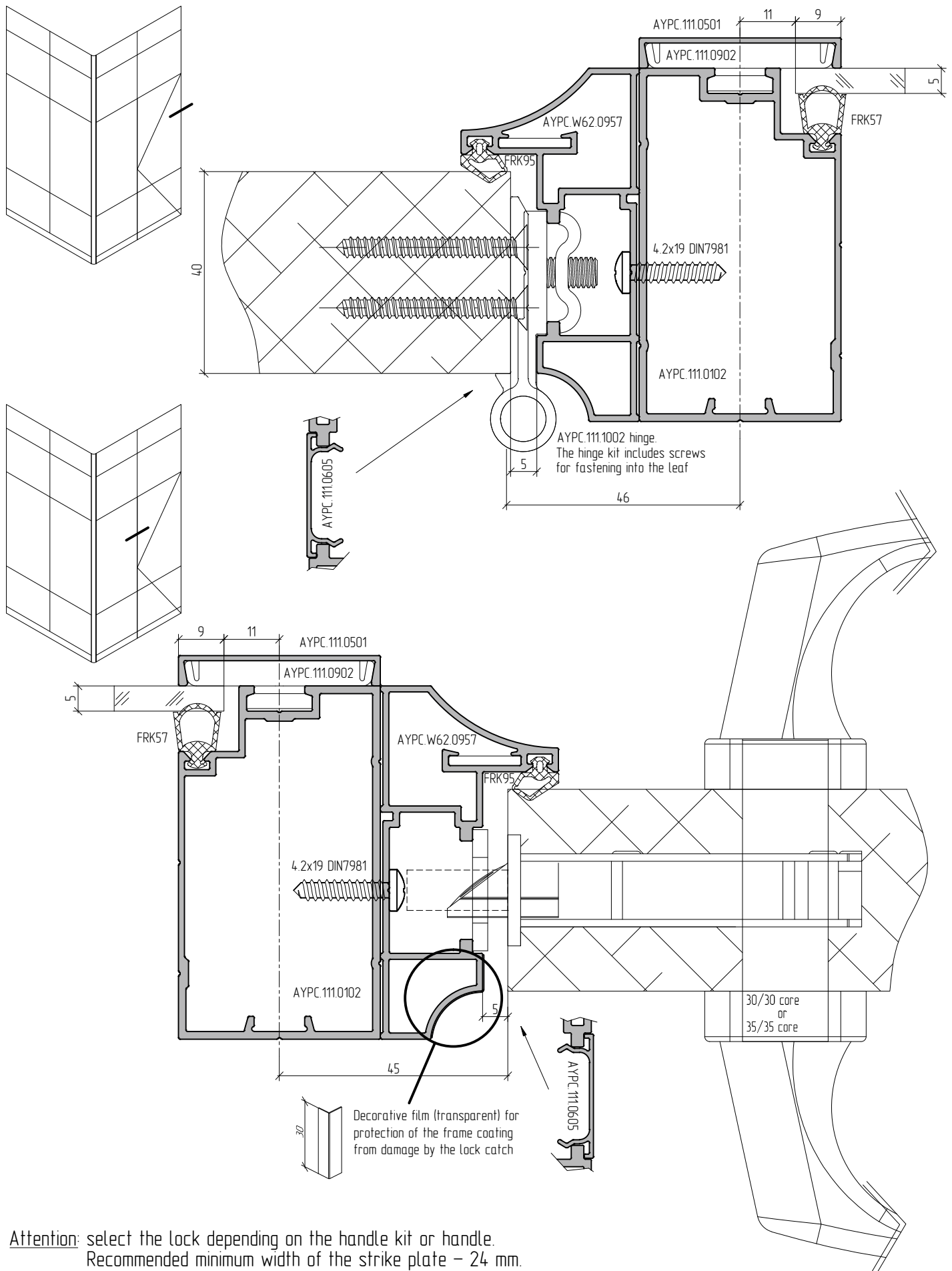

**Attention:** select the lock depending on the handle kit or handle.  
Recommended minimum width of the strike plate – 24 mm.

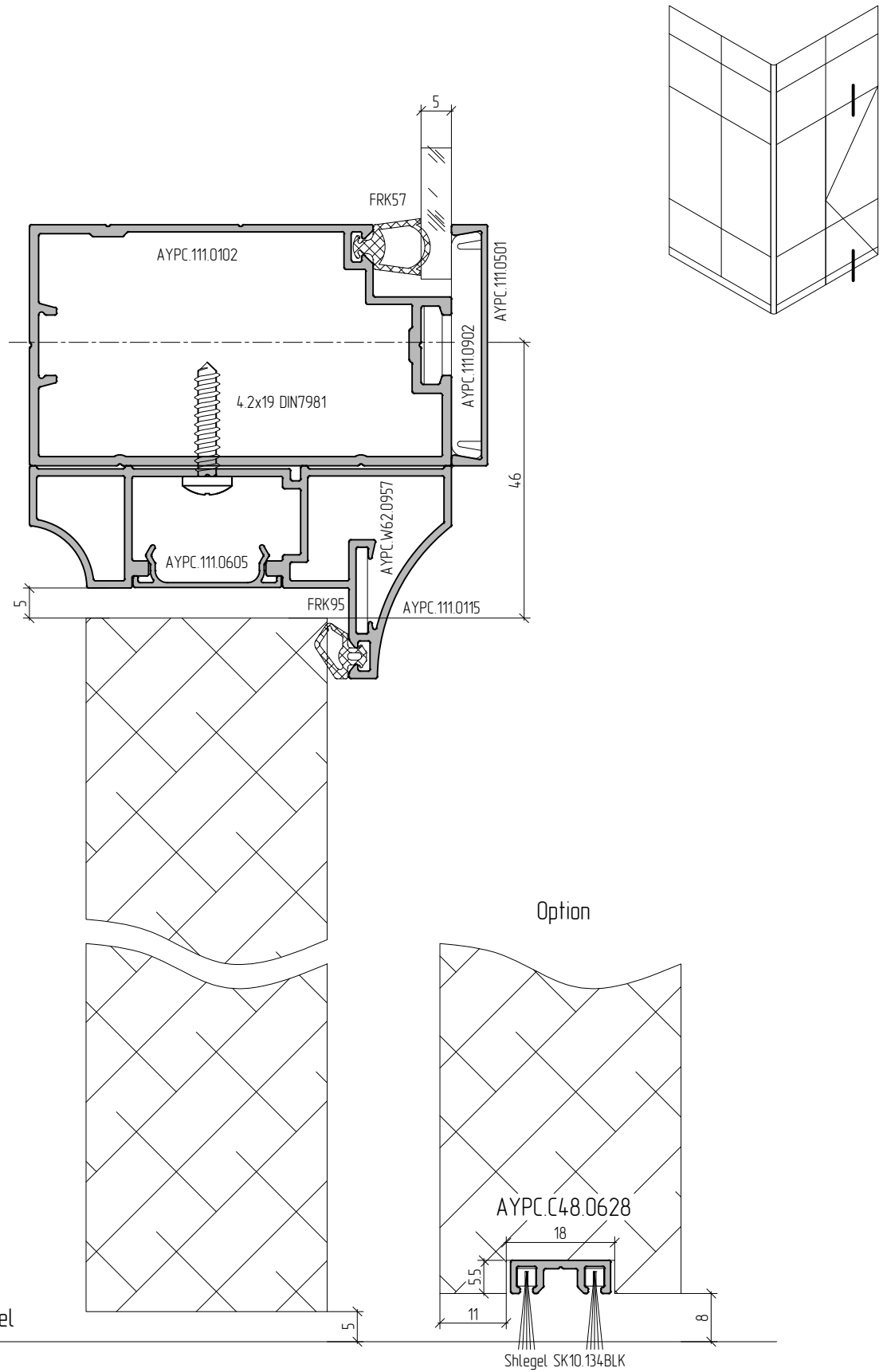

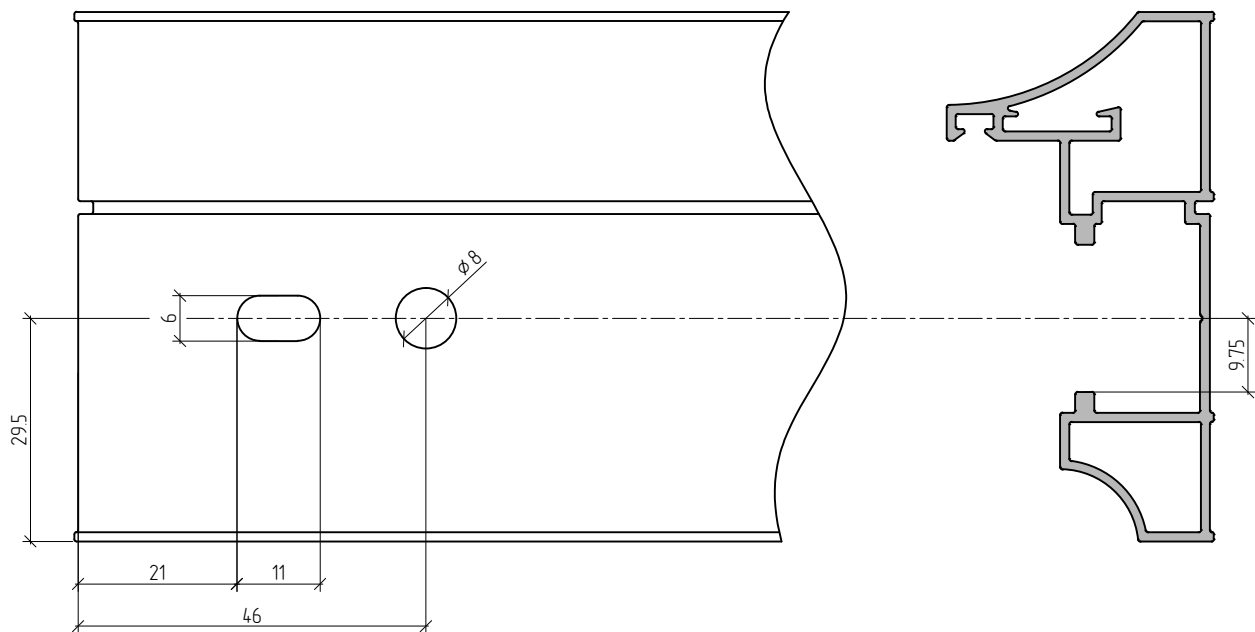
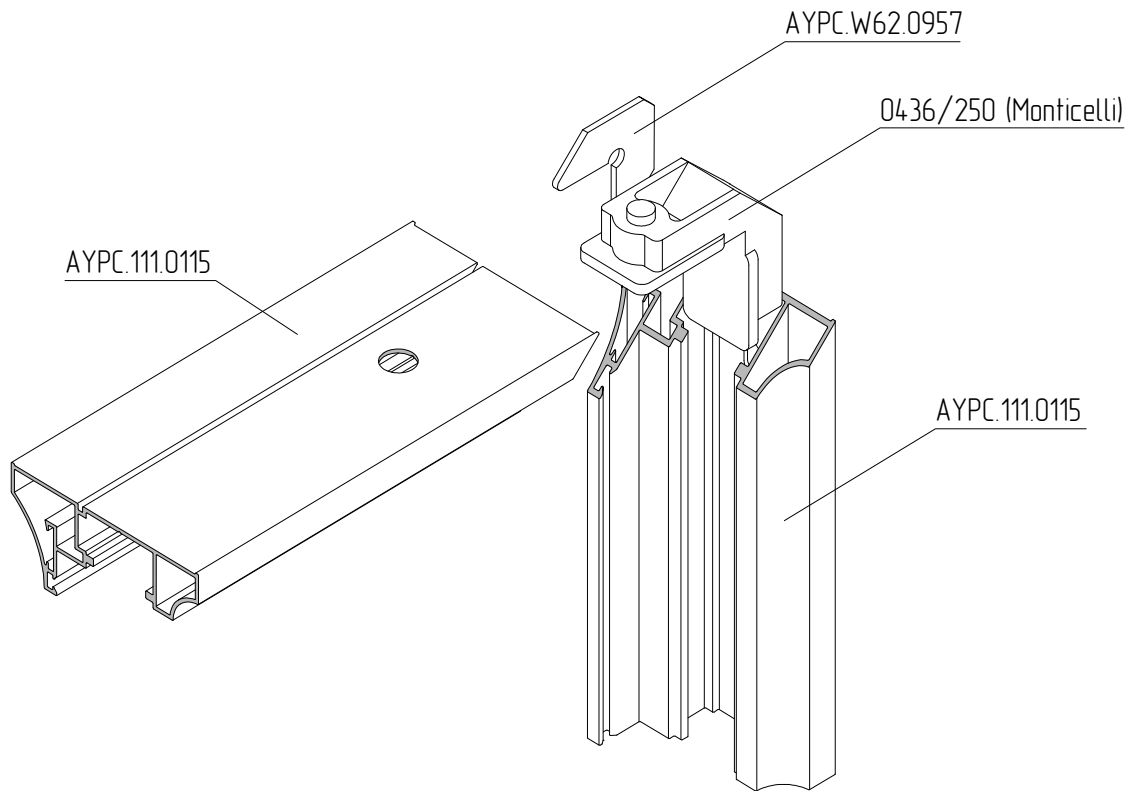

Installation of standard door into 75-105 mm and 105-135 mm apertures

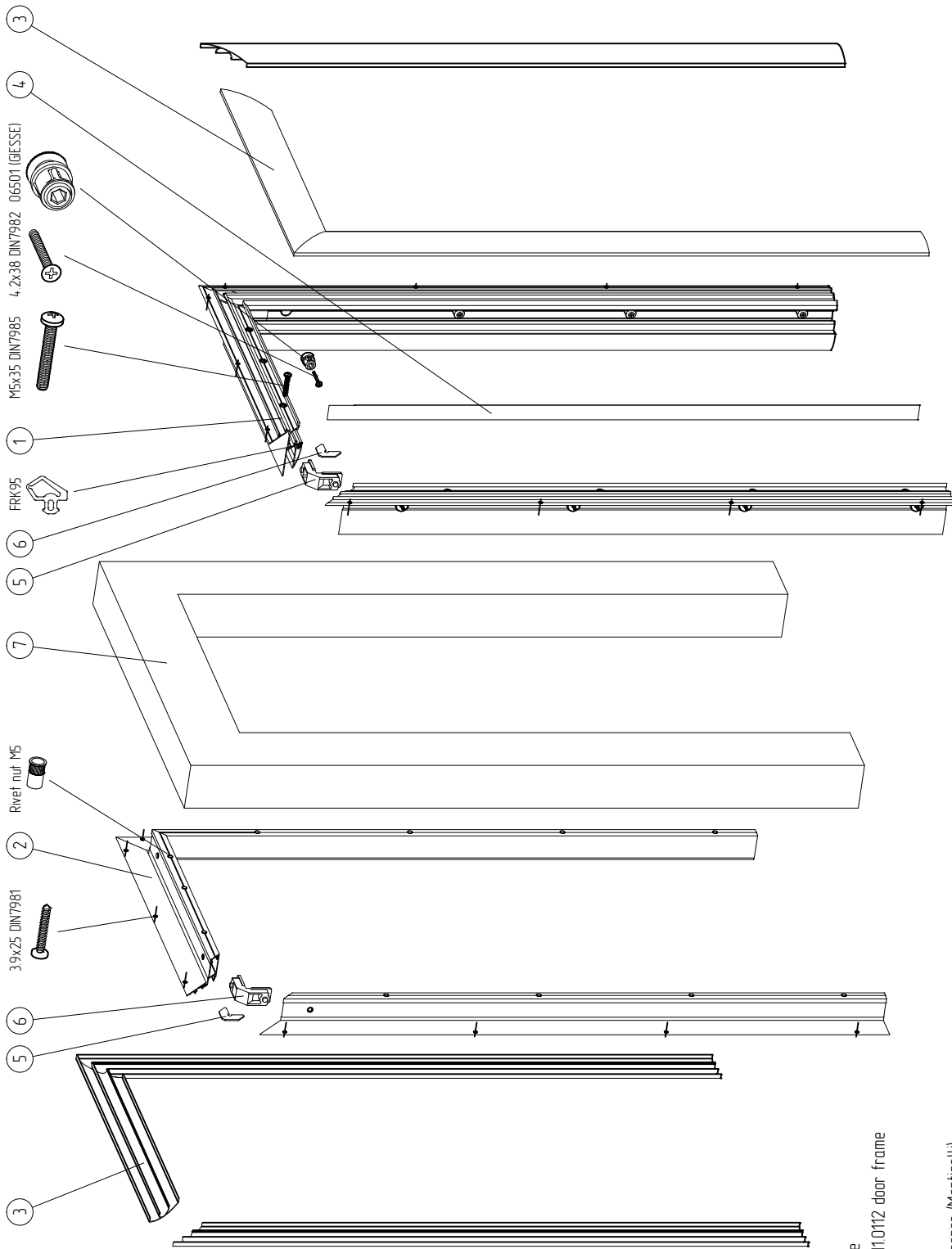

- 1 - A-YPC.111.0110 door frame
- 2 - A-YPC.111.0111 or A-YPC.111.0112 door frame
- 3 - A-YPC.111.0114 trim
- 4 - A-YPC.111.0605 cover
- 5 - O4-36/250 connection corner (Monticelli)
- 6 - A-YPC.W62.0957 leveling corner
- 7 - aperture

Installation of standard door into the apertures from 135 to 270 mm

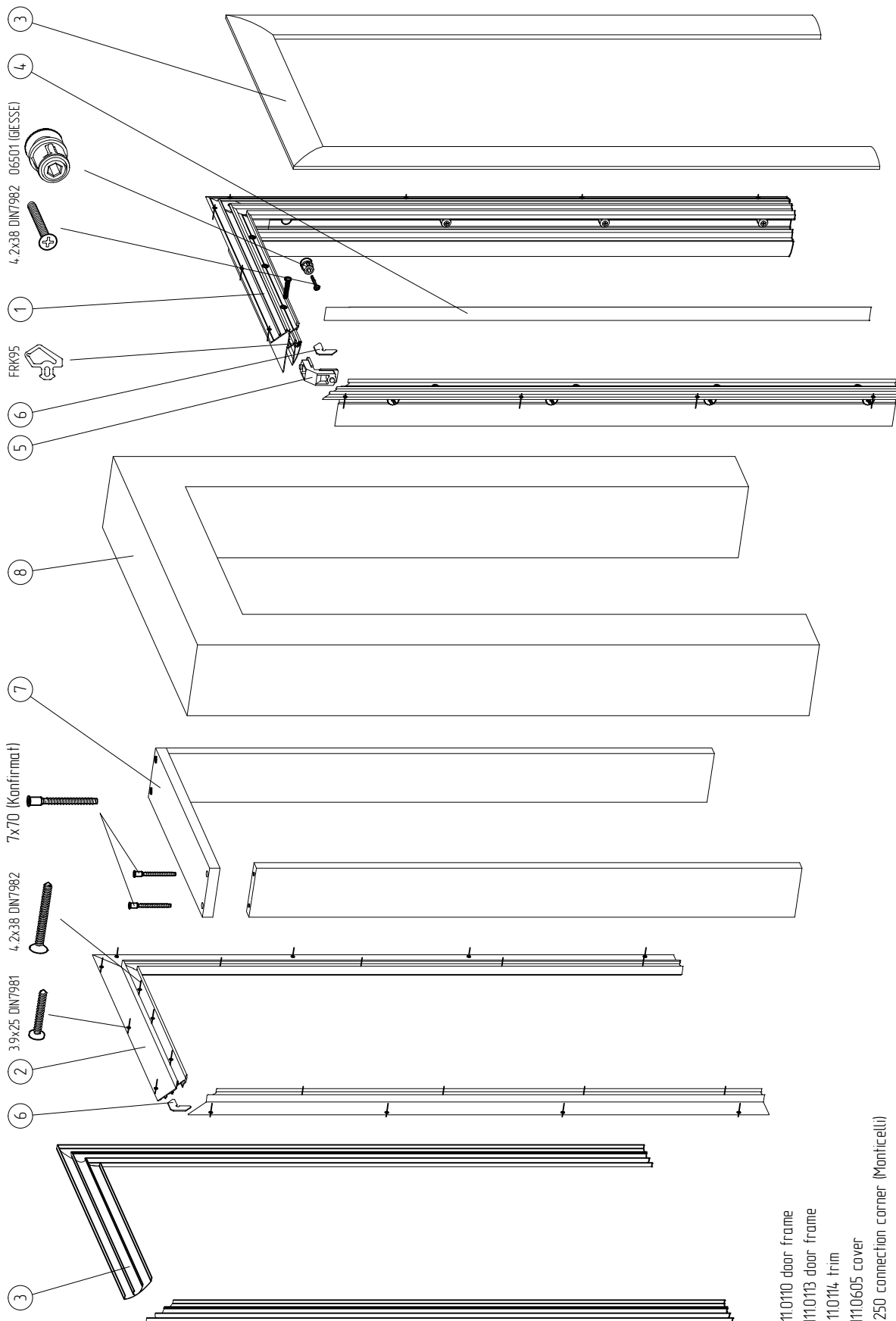

- 1 - AYPC.111.0110 door frame
- 2 - AYPC.111.0113 door frame
- 3 - AYPC.111.0114 trim
- 4 - AYPC.111.0605 cover
- 5 - 04.36/250 connection corner (Monticelli)
- 6 - AYPC.W62.0957 leveling corner
- 7 - particle board frame (18 mm thick)
- 8 - aperture

Profile corner connection

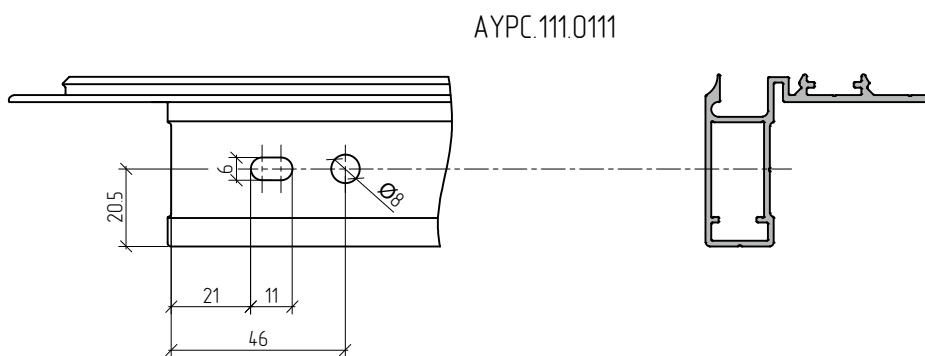
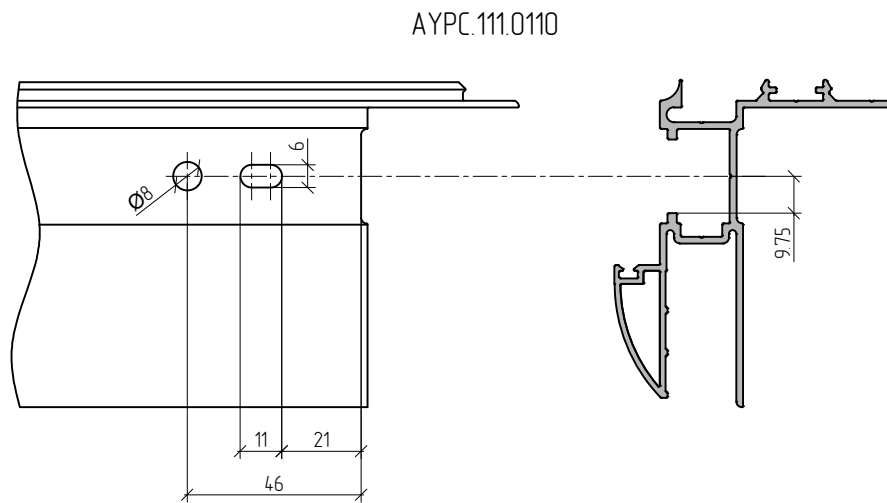
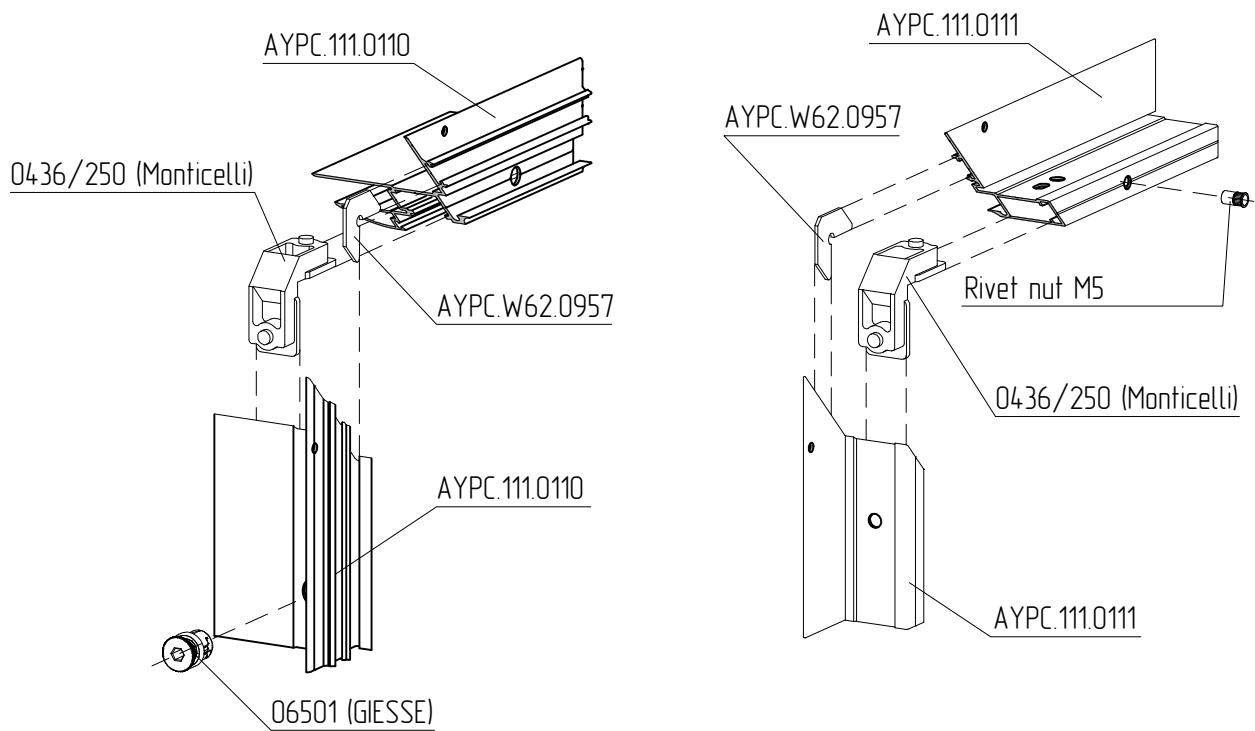

Attention! Horizontal profiles should be processed for further swivel screw installation.

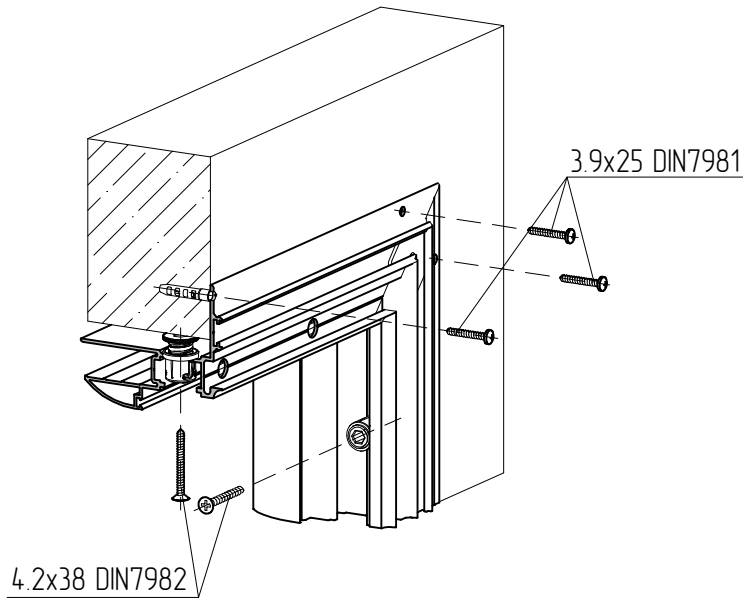

Option of profile connection on screws

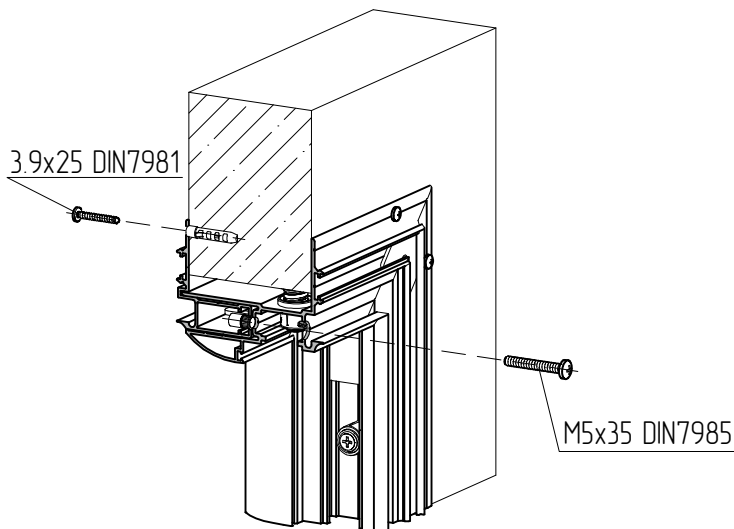

Option of profile connection on self-tapping screws

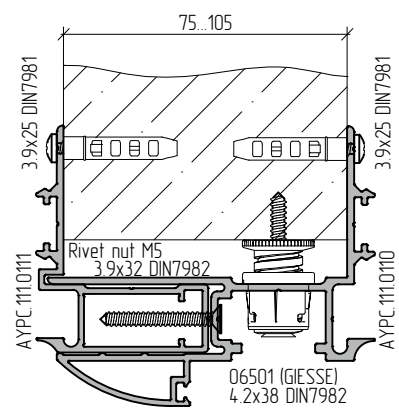
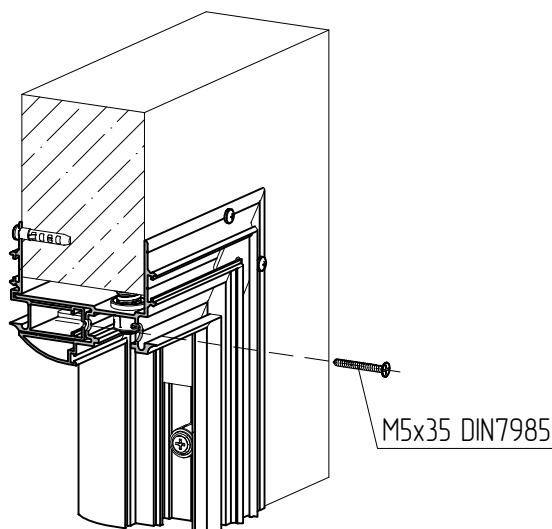
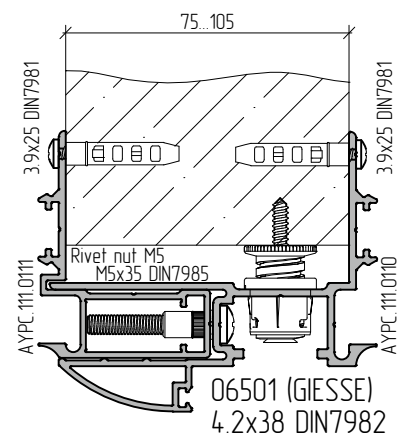

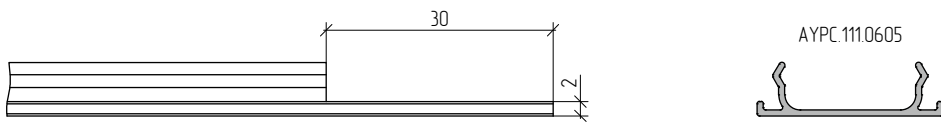
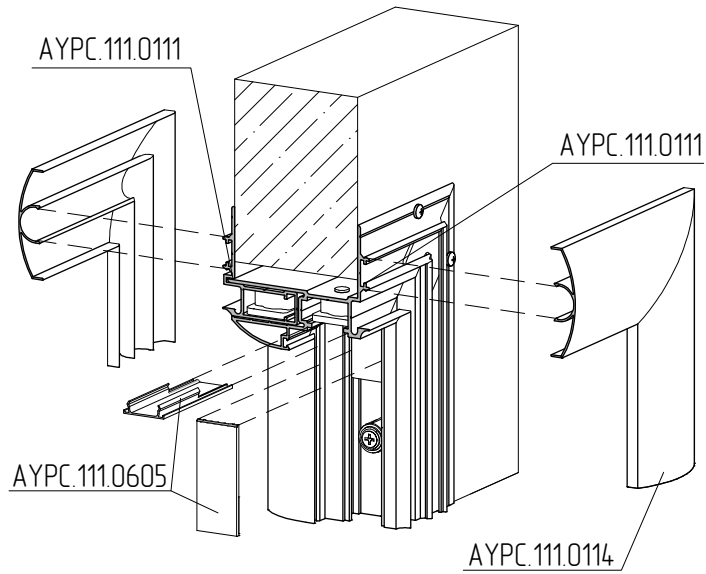

Option for wall board 75 - 105 mm thick

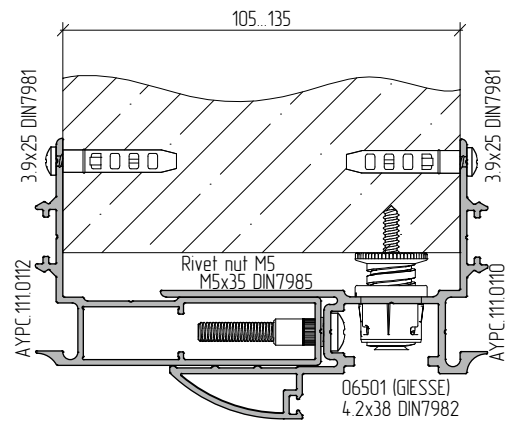
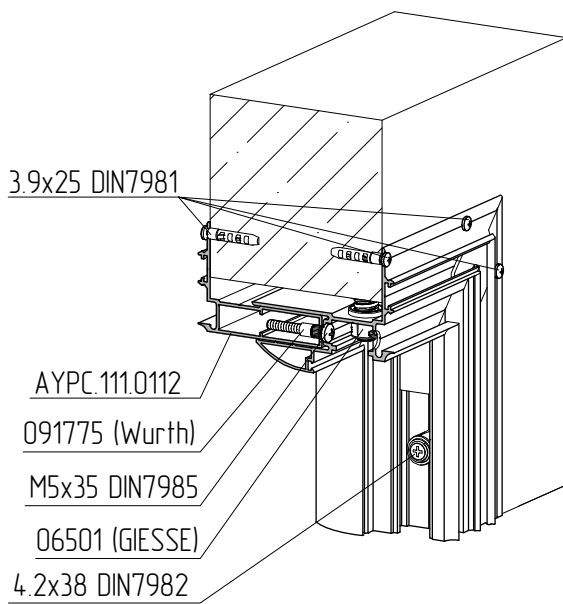



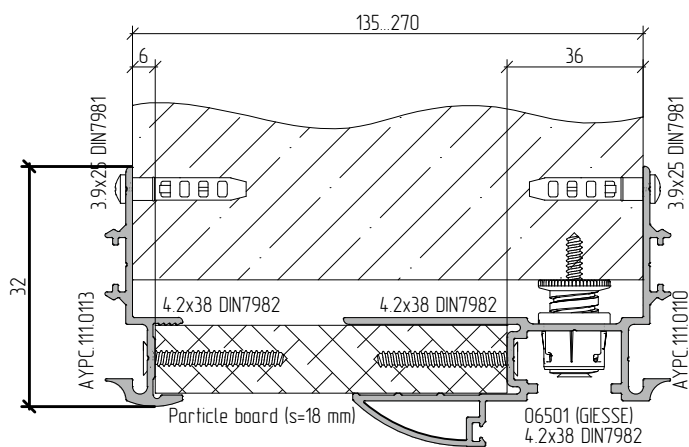
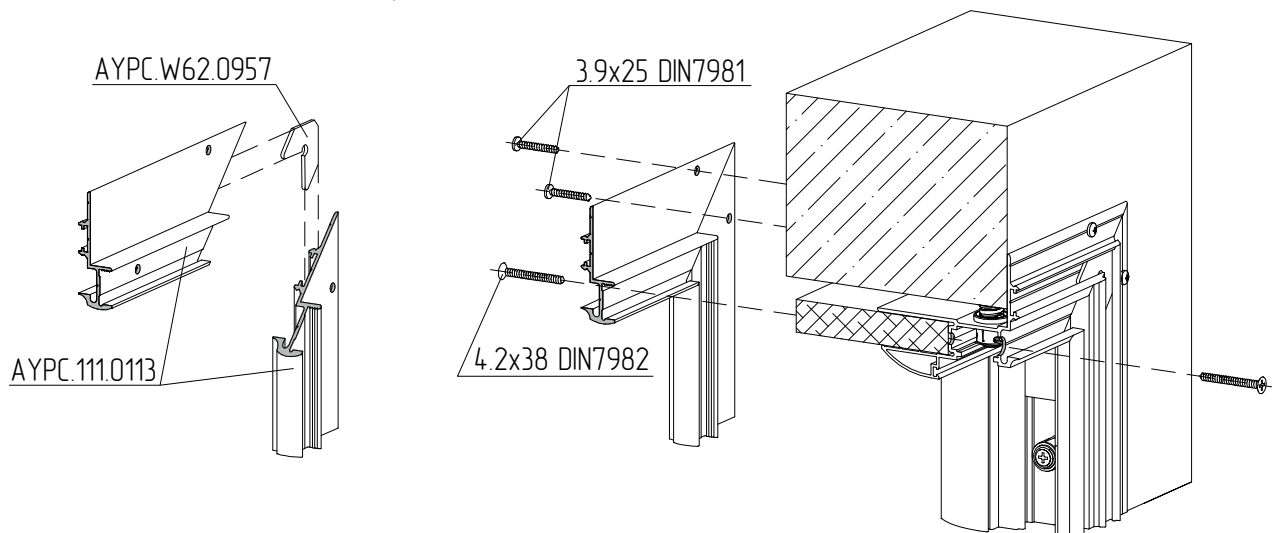
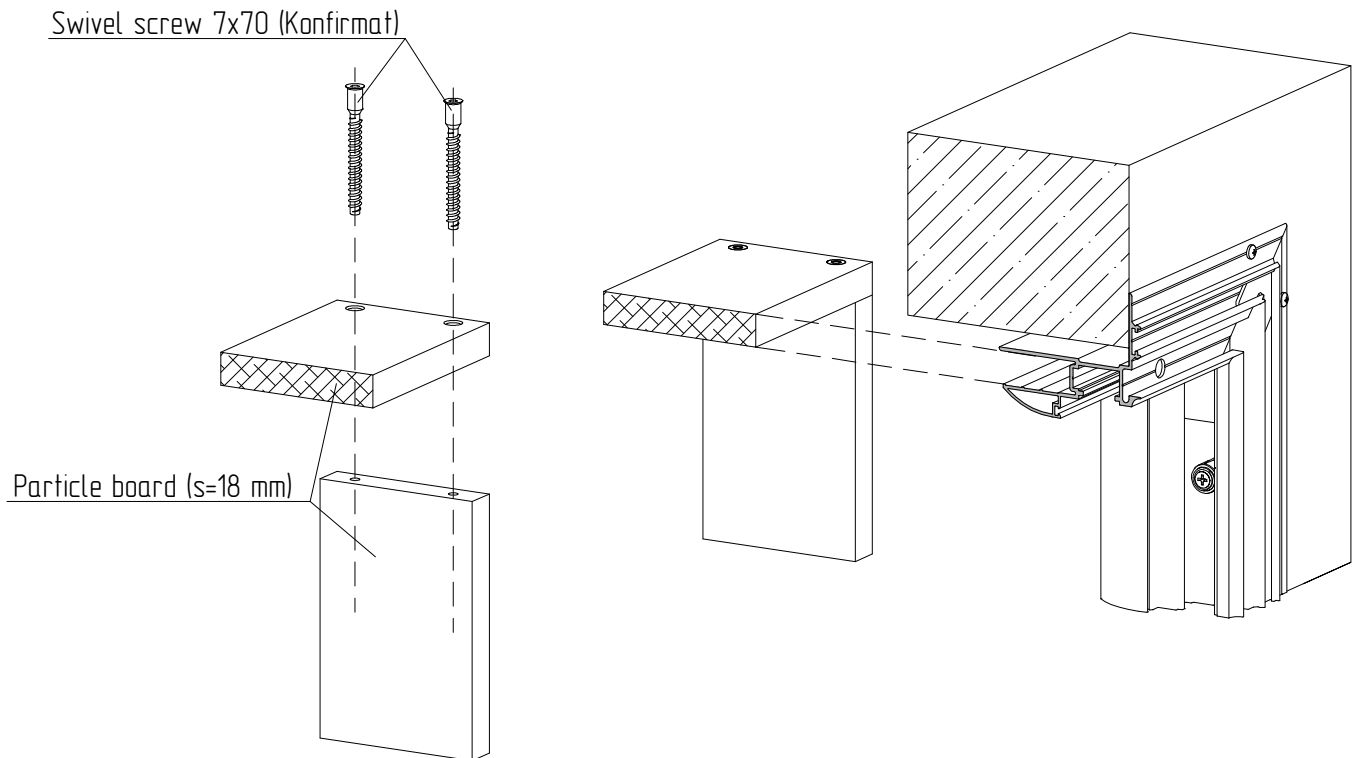

Partition installation into the door opening depending on the wall thickness. AYPC.111.0114 trim

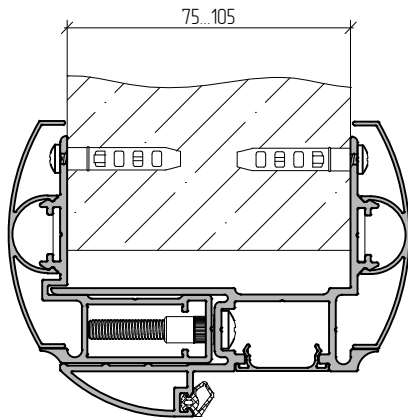

For the wall board 75 to 105 mm thick

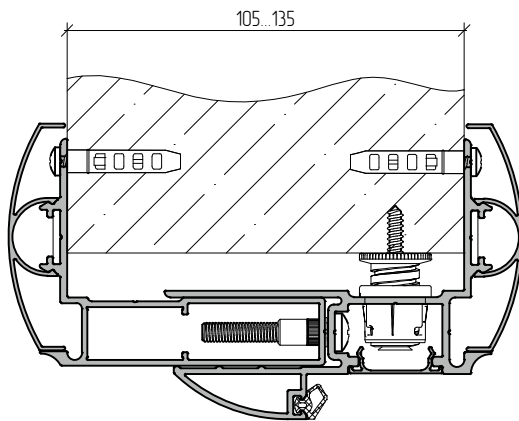

For the wall board 105 to 135 mm thick

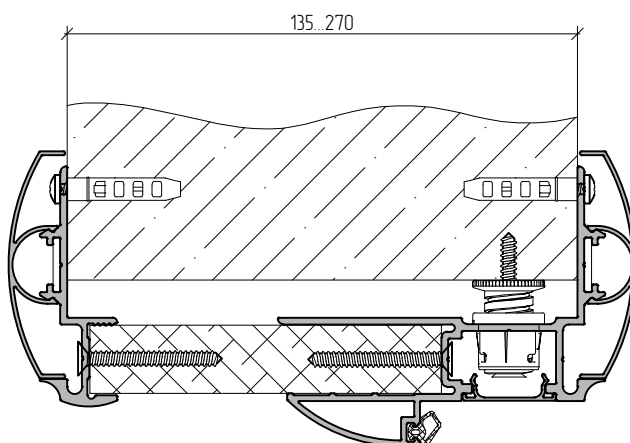

For the wall board 135 – 270 mm thick

Partition installation into the door opening depending on the wall thickness. AYPC.111.0118 trim

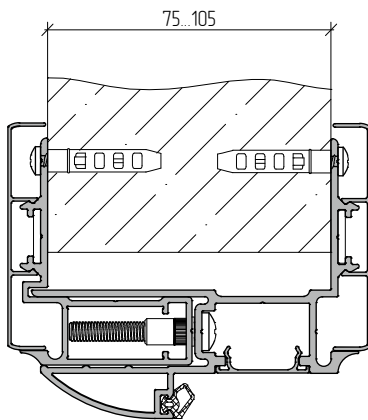

For the wall board 75 to 105 mm thick

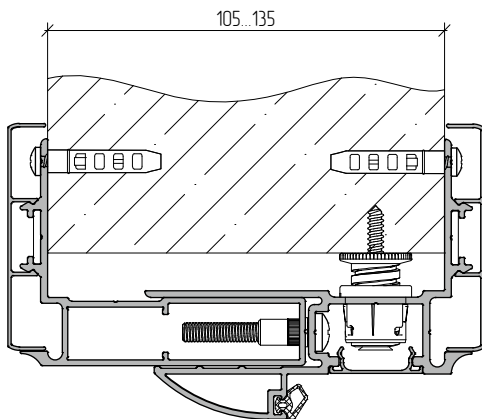

For the wall board 105 to 135 mm thick

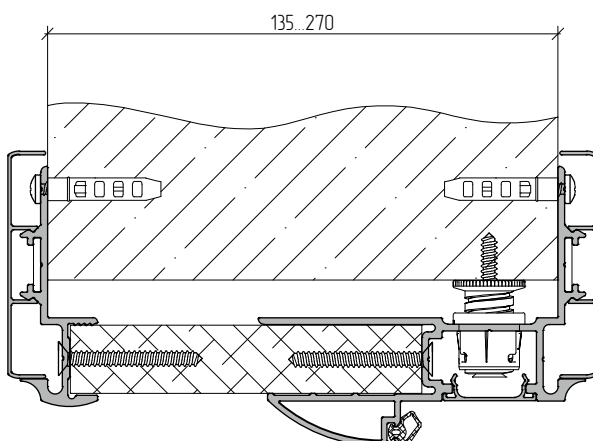

For the wall board 135 to 270 mm thick

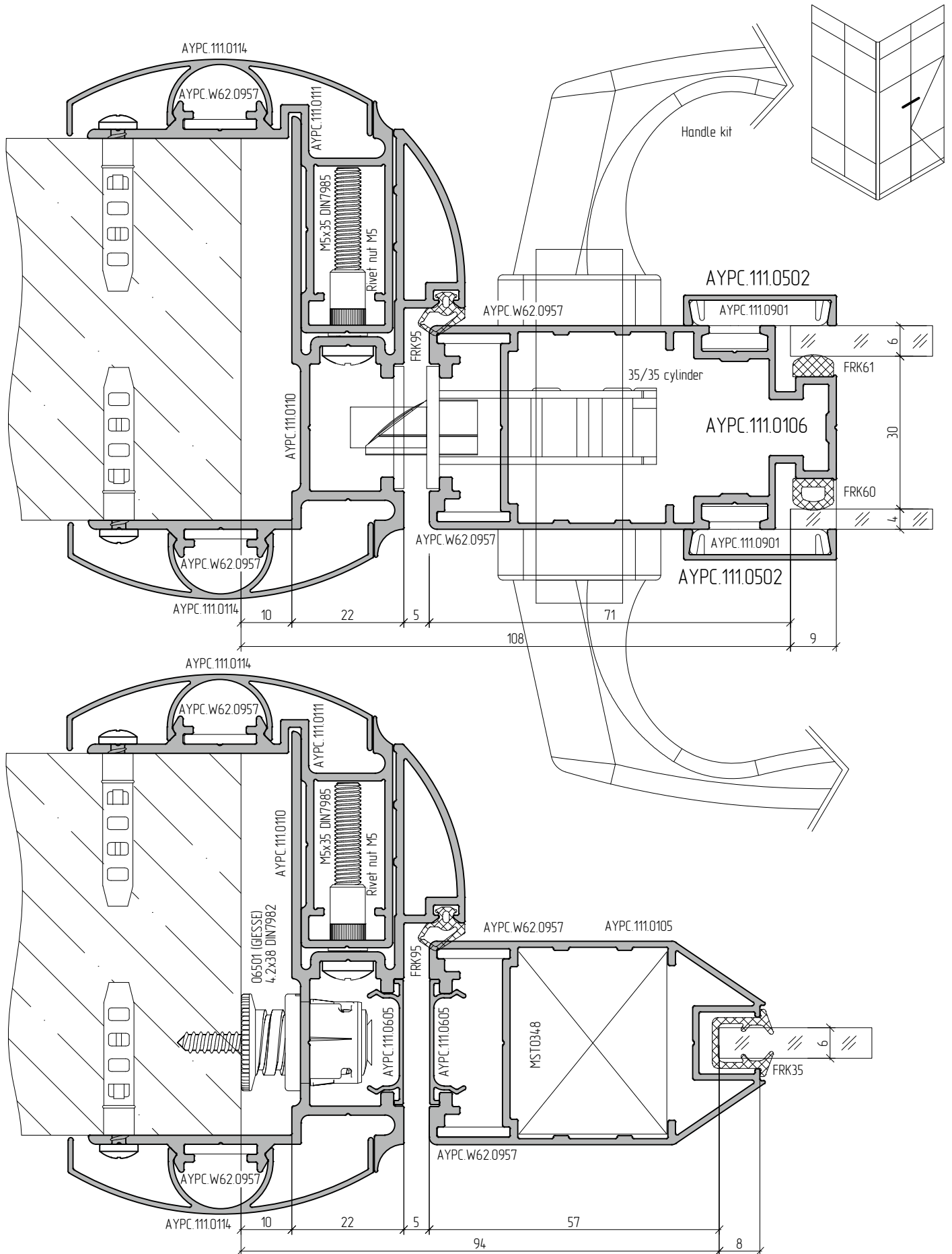

- 01
- 02
- 03
- 04
- 05
- 06
- 07
- 08
- 09
- 10
- 11
- 12
- 13
- 14

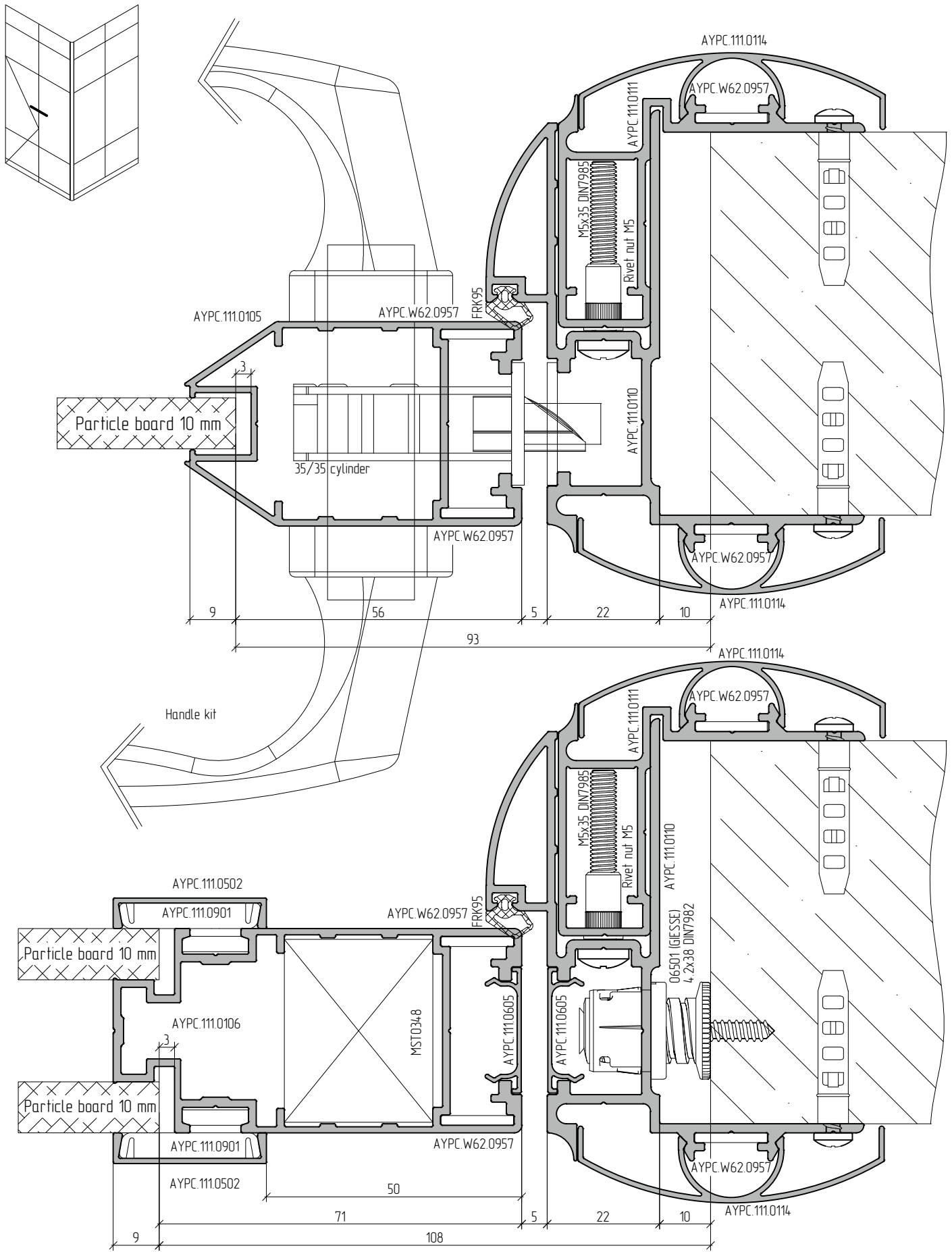

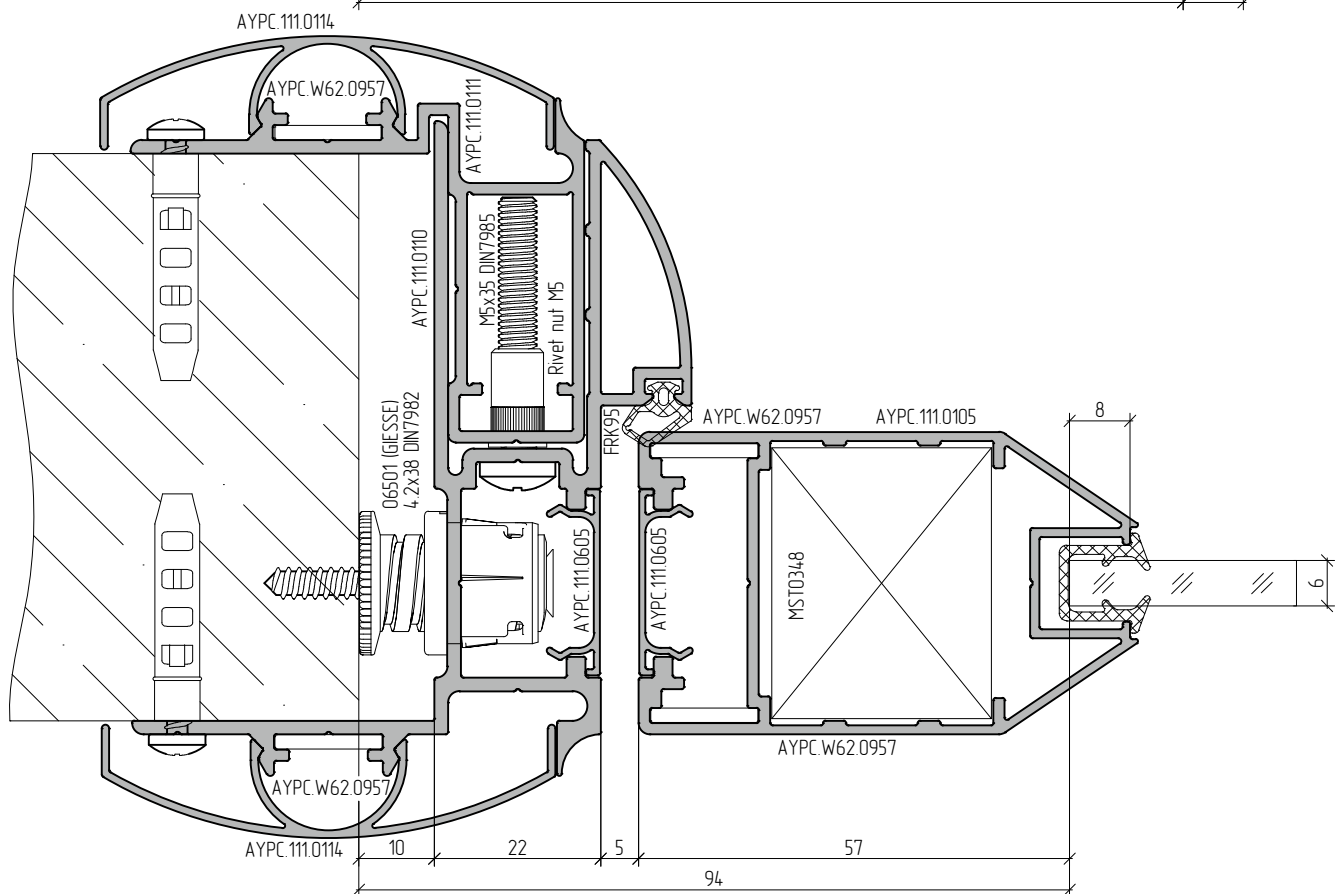
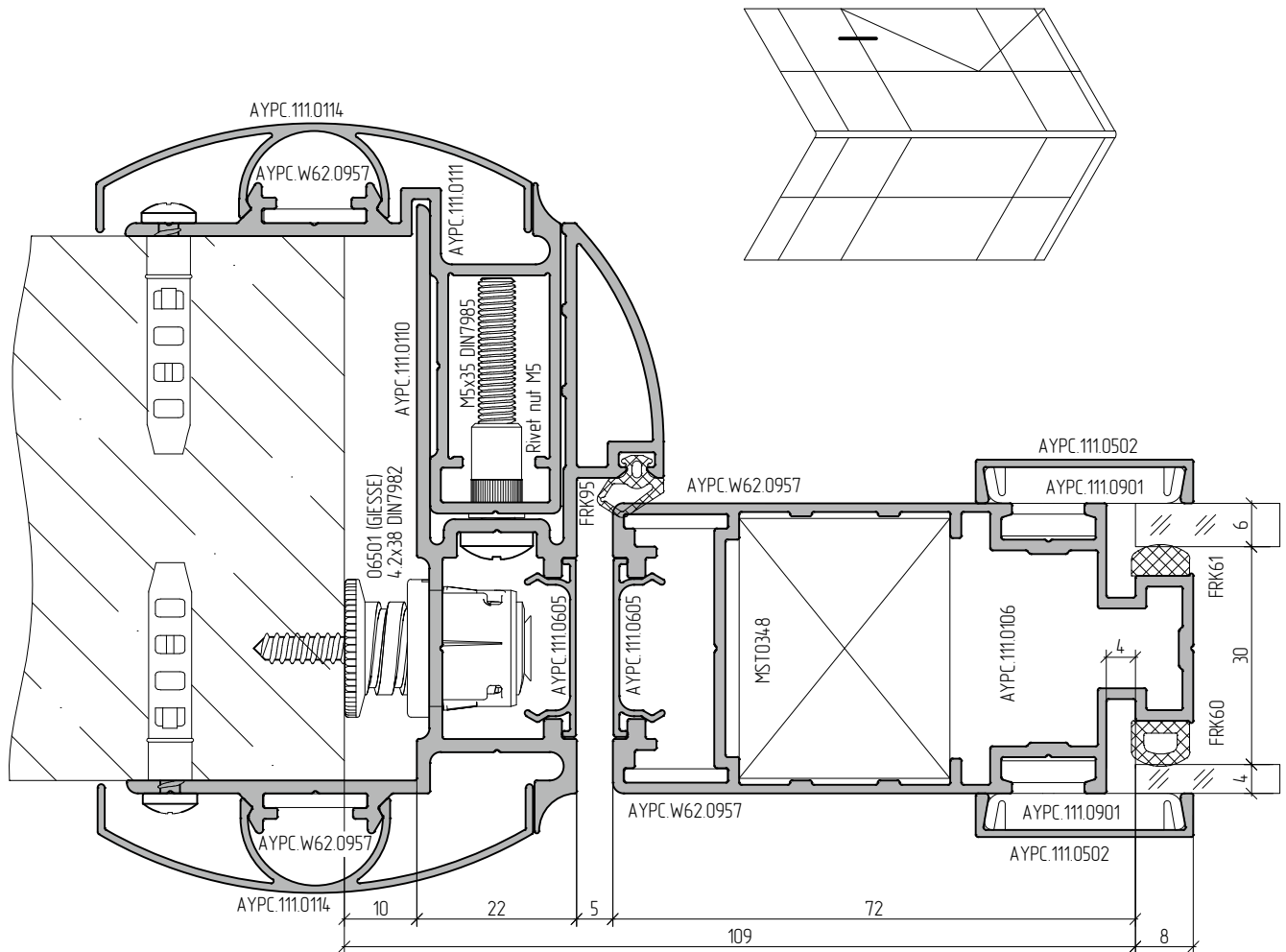

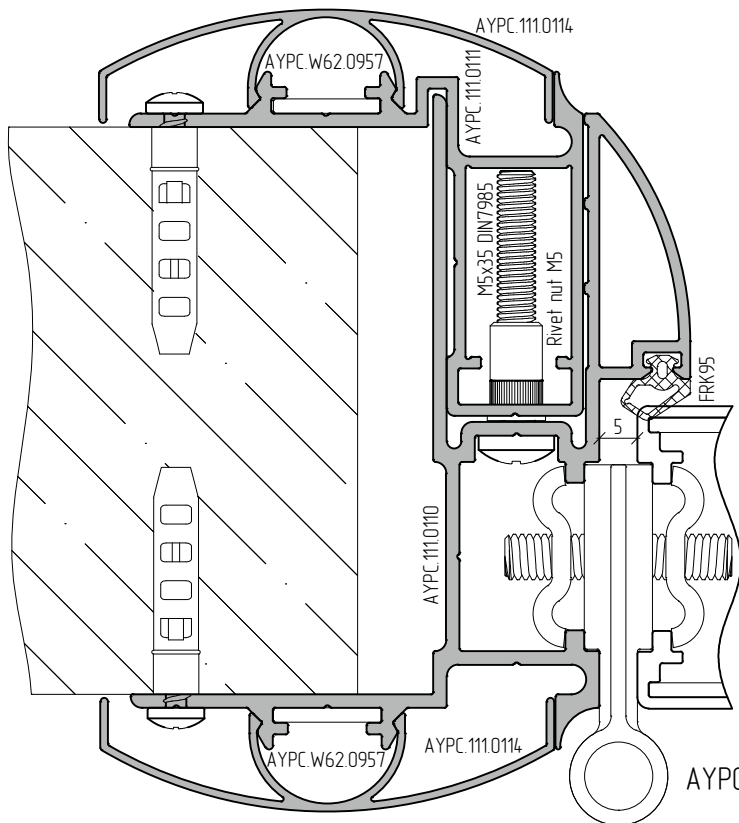

Hinges installation

Article	Qty of hinges, pcs	Max. leaf weight, kg	
		Without door closer	With door closer
AYPC.111.1001	2	60	42
	3	70	49
AYPC.111.1006	2	85	59
	3	115	80

Leaves  
AYPC.111.0105  
AYPC.111.0106

AYPC.111.1001 hinge

Hinges positioning

Two hinges

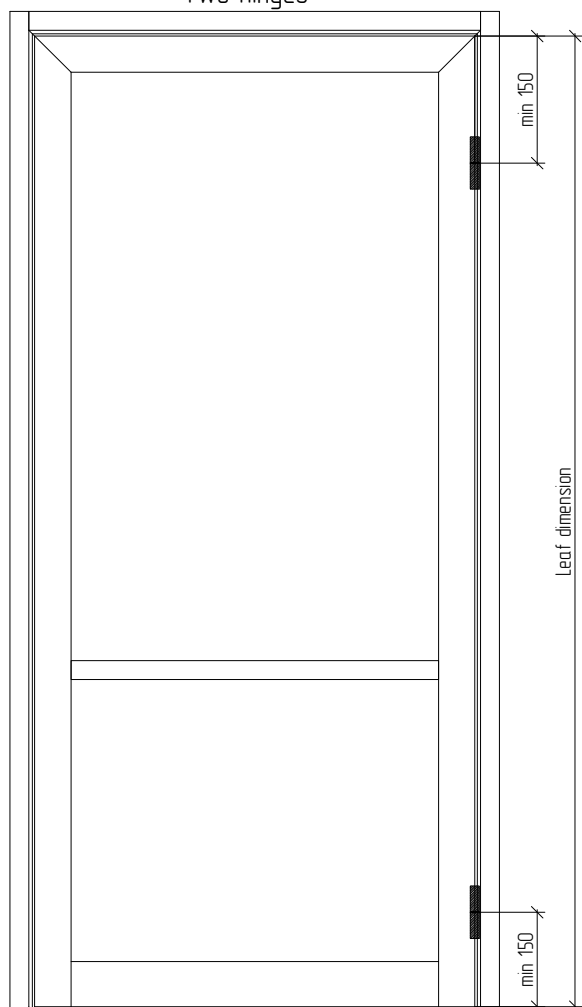

Three hinges

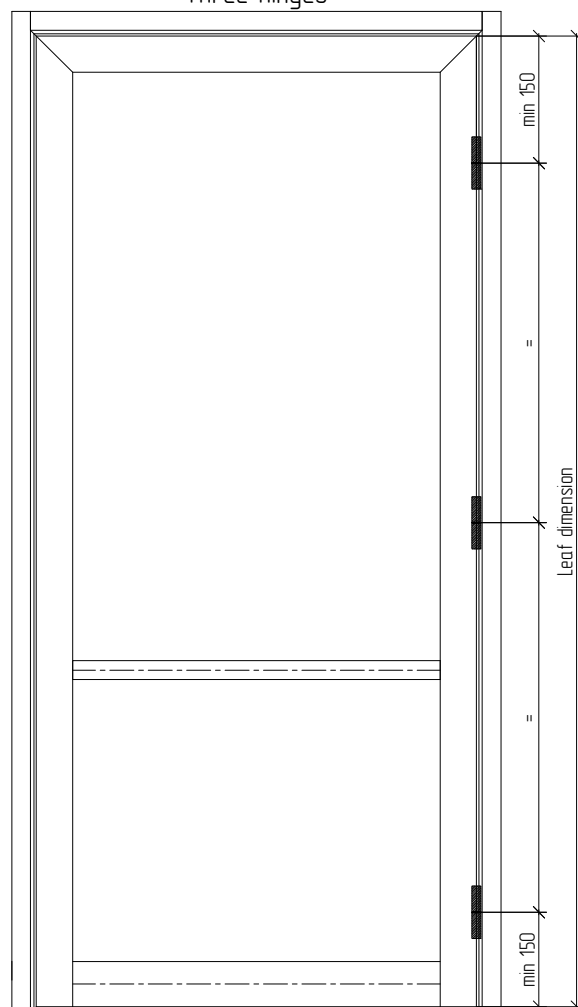

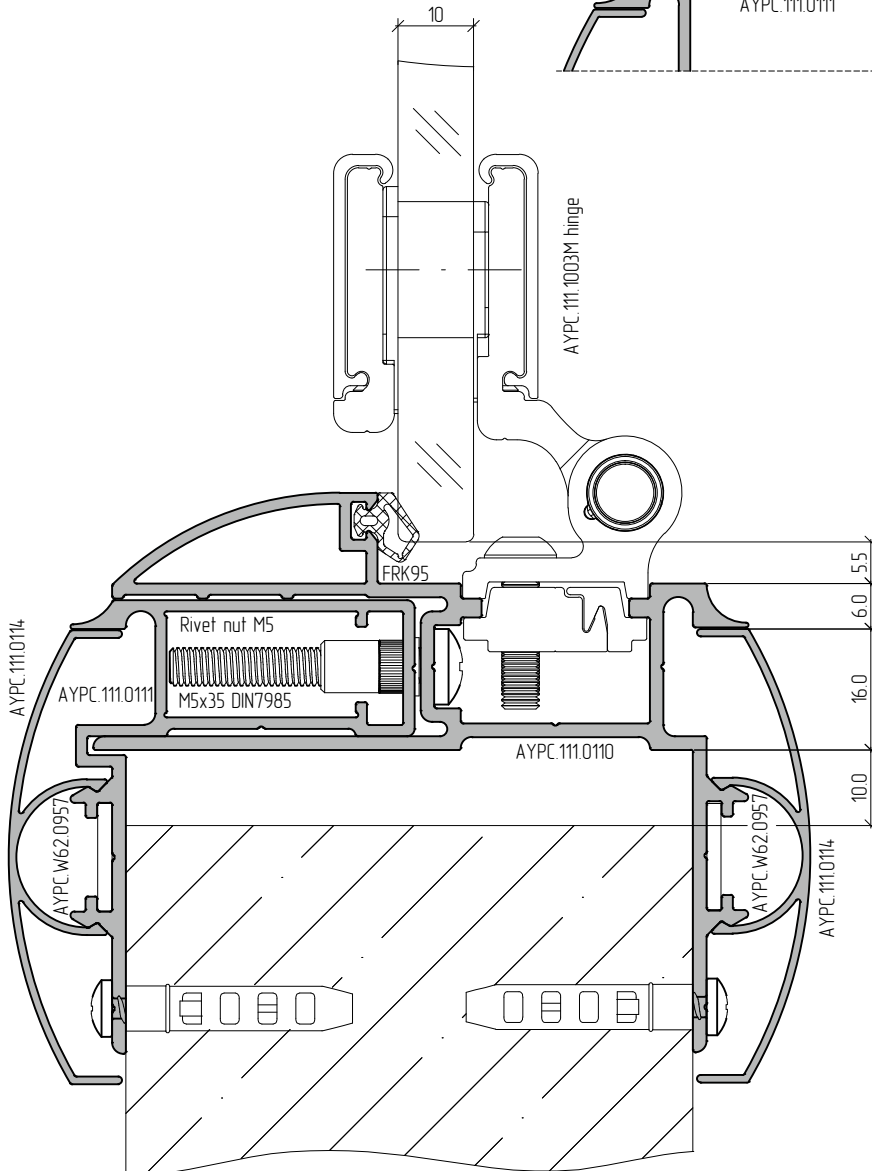
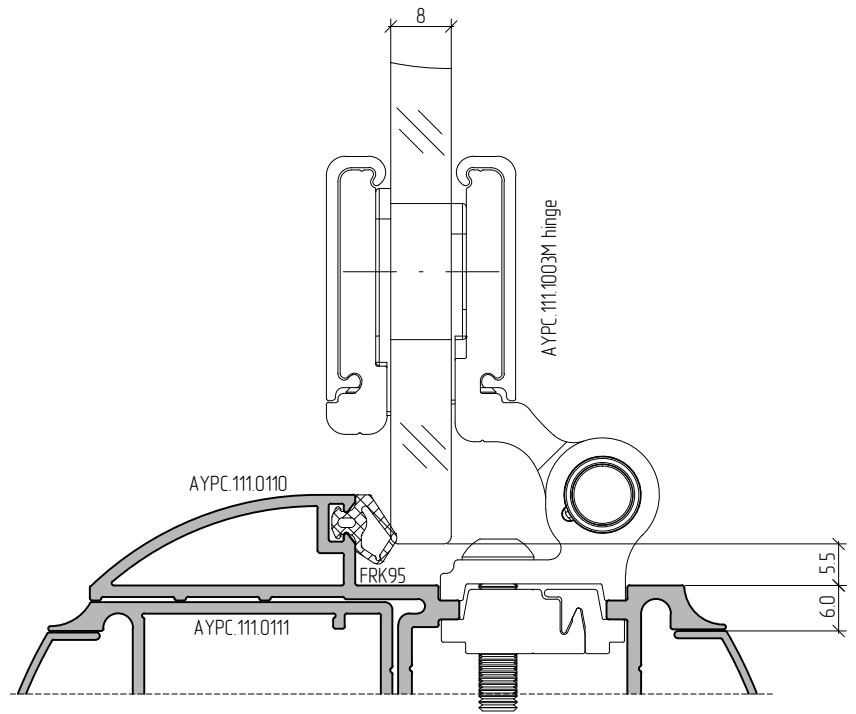
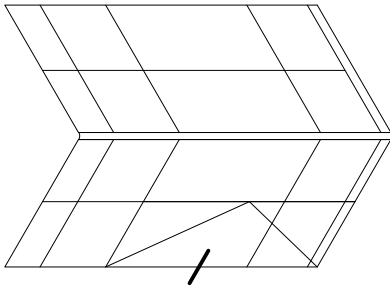



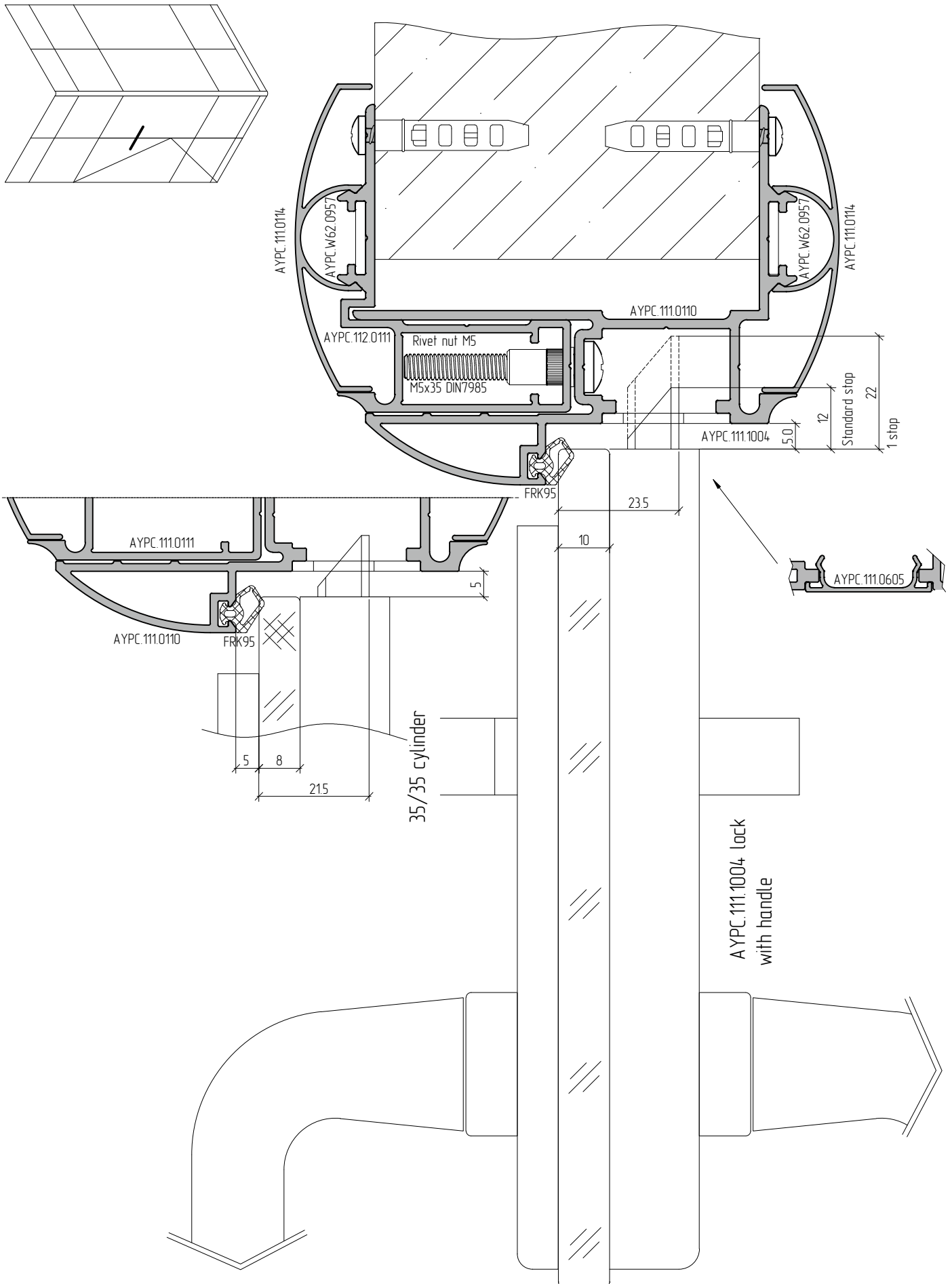

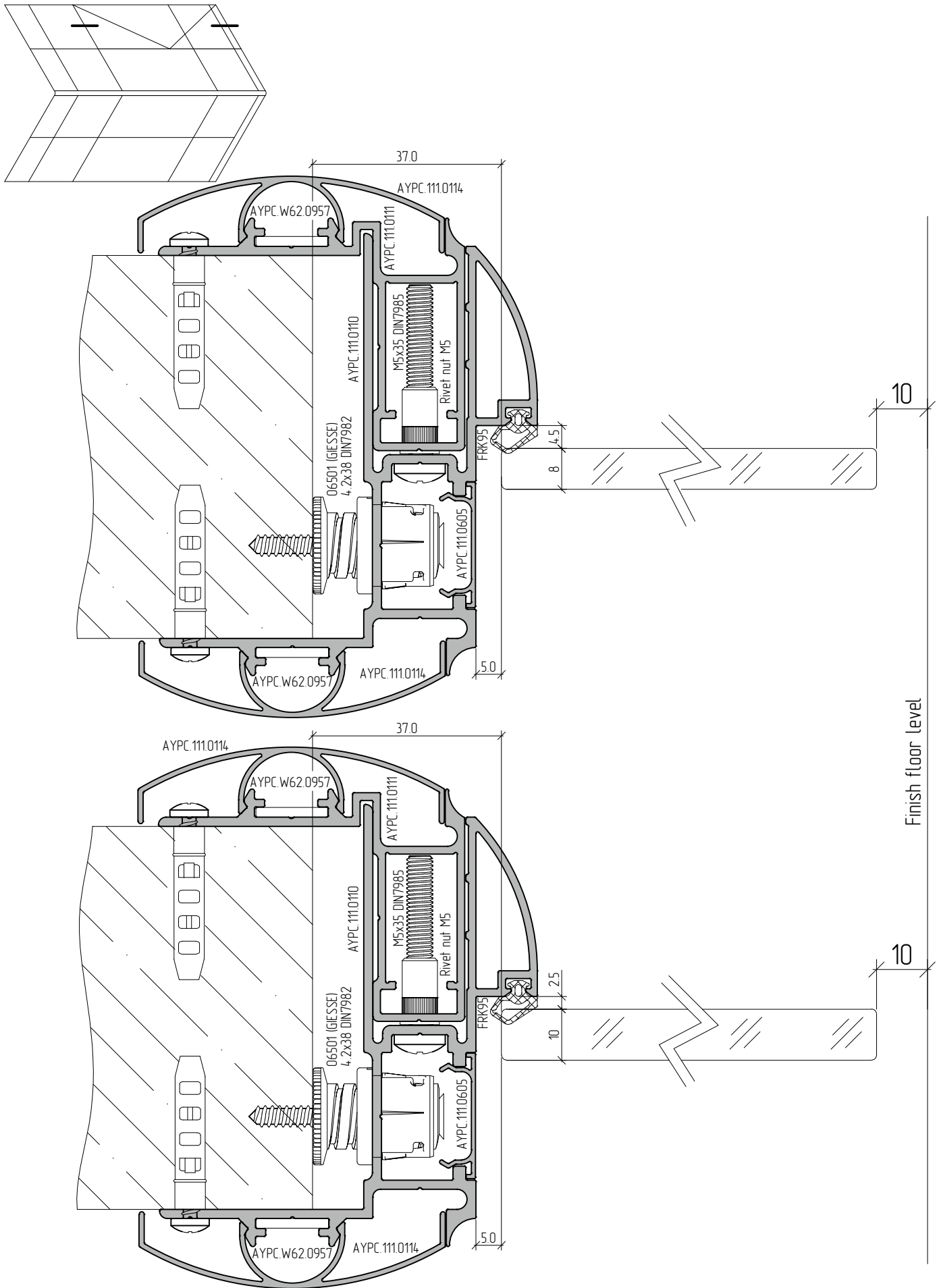

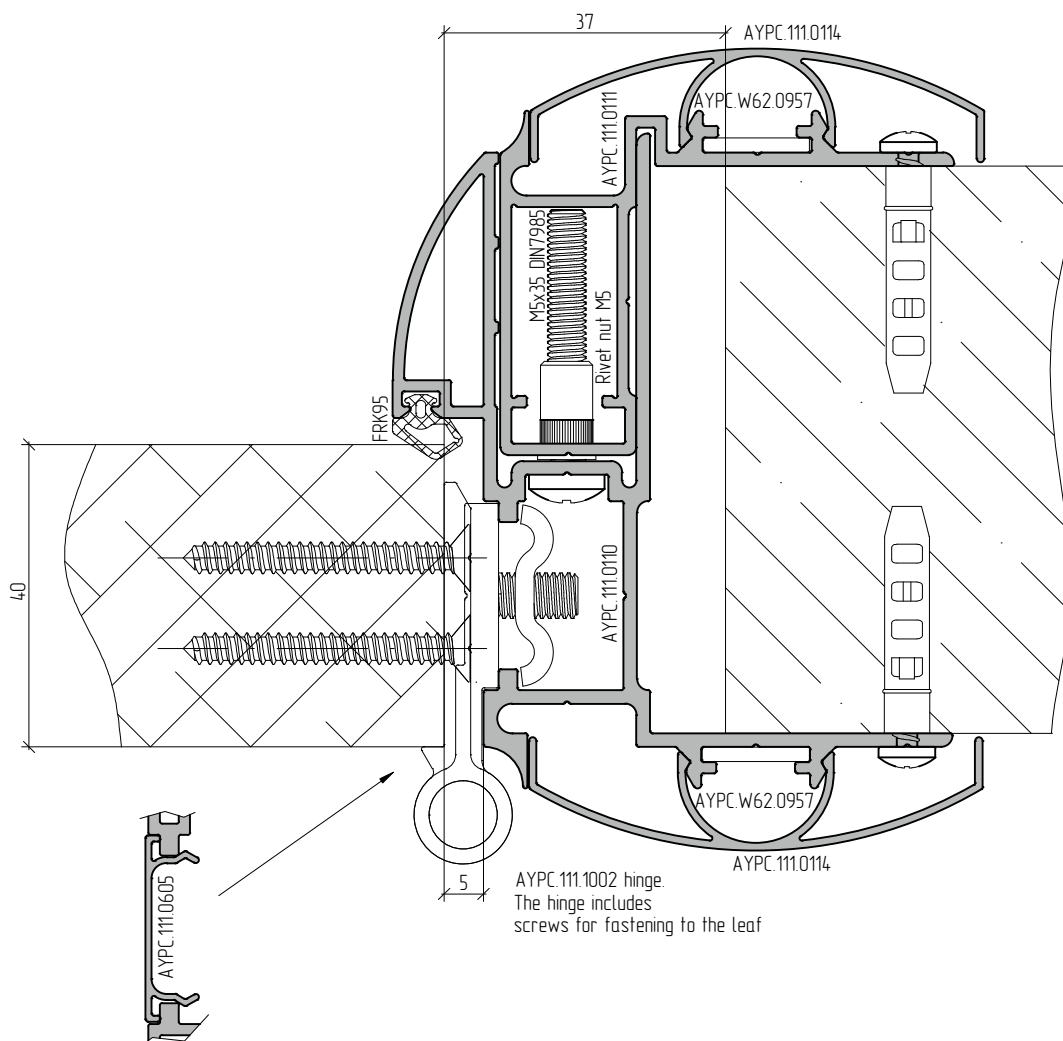
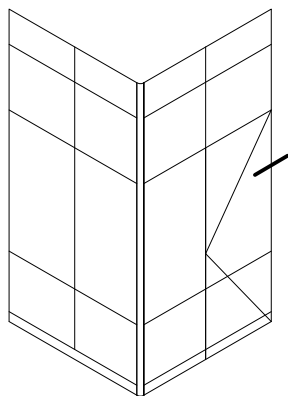

**Attention:** select the lock depending on the handle kit or handle.  
Recommended minimum width of the strike plate – 24 mm.

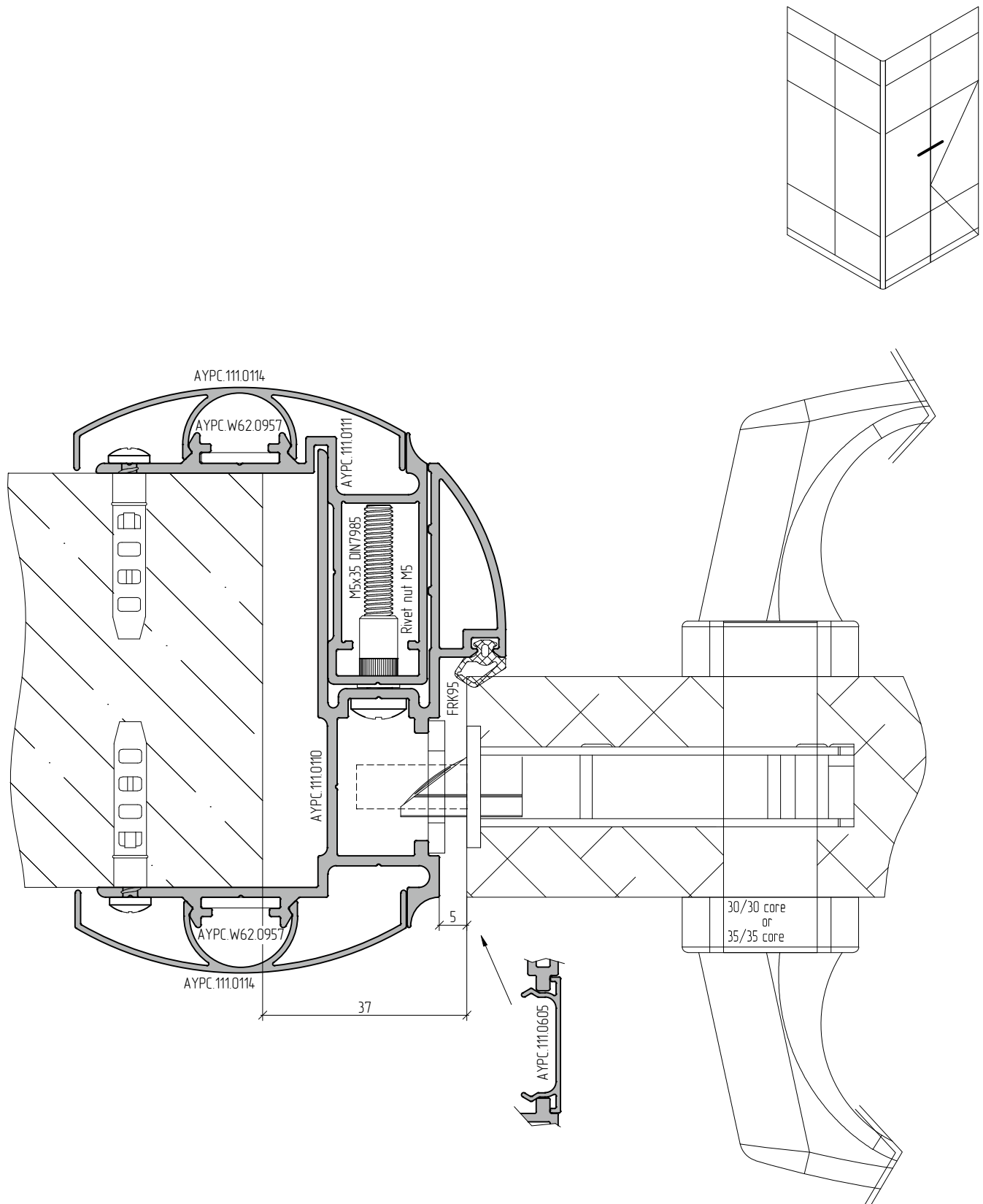

**Attention:** select the lock depending on the handle kit or handle.  
Recommended minimum width of the strike plate – 24 mm.

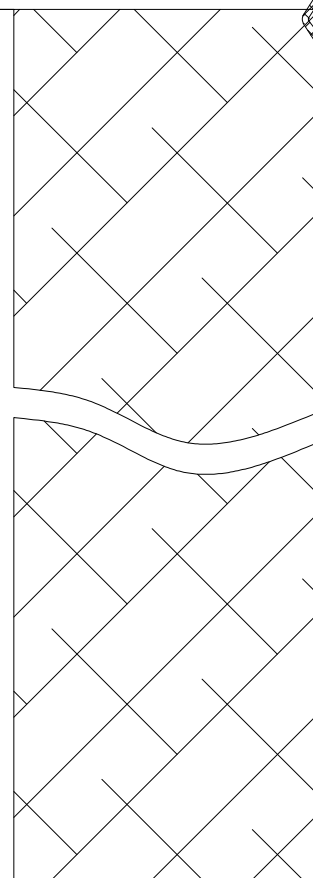
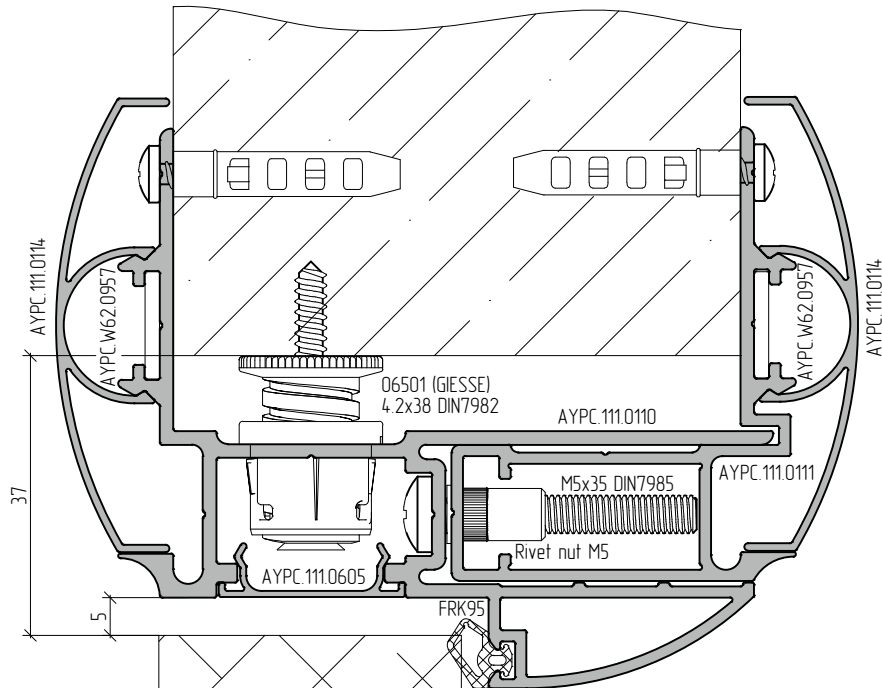
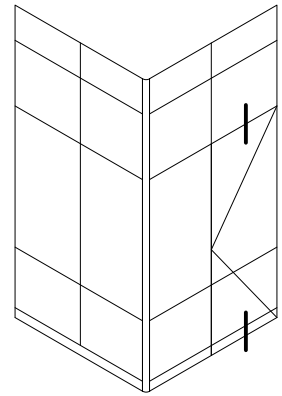

Option

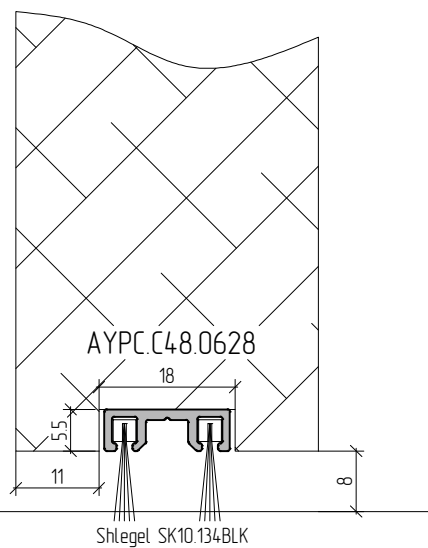

Finished floor level

Hinge installation

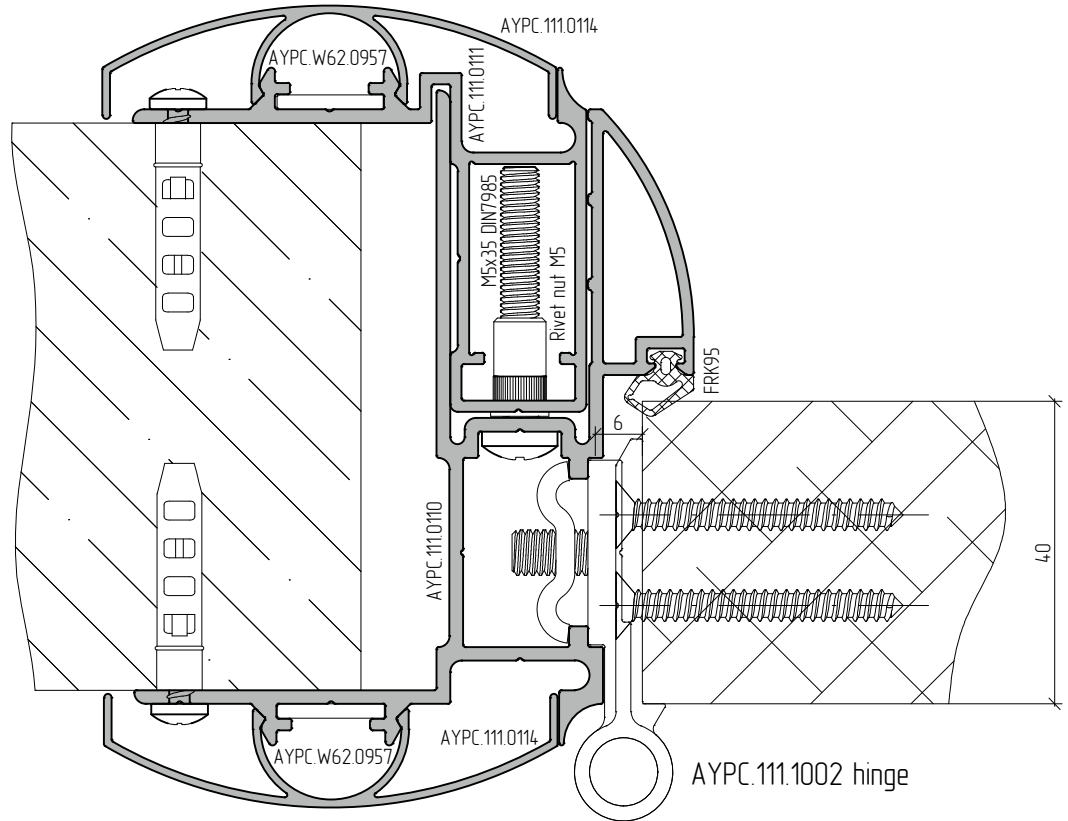

Two hinges

Hinges positioning

Three hinges

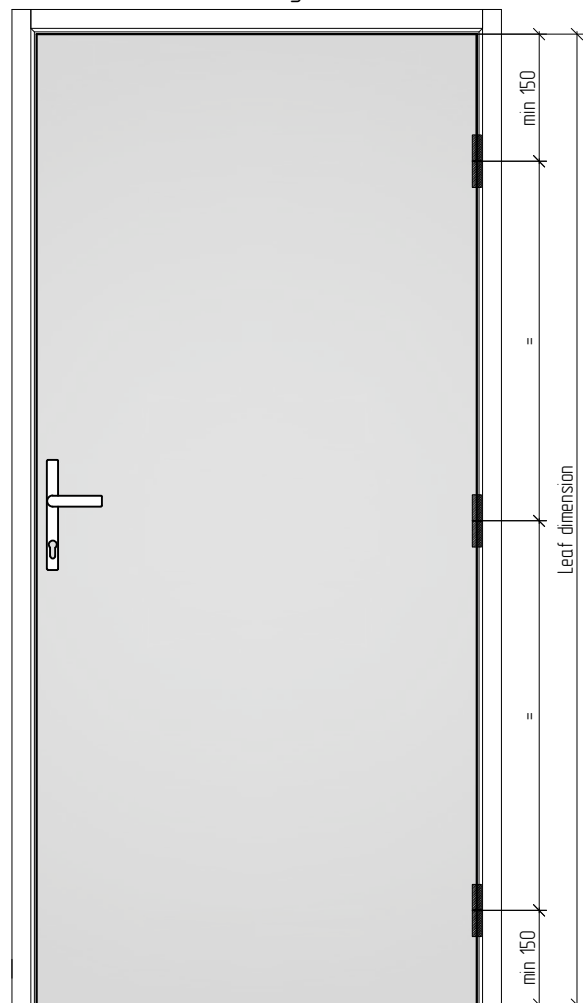
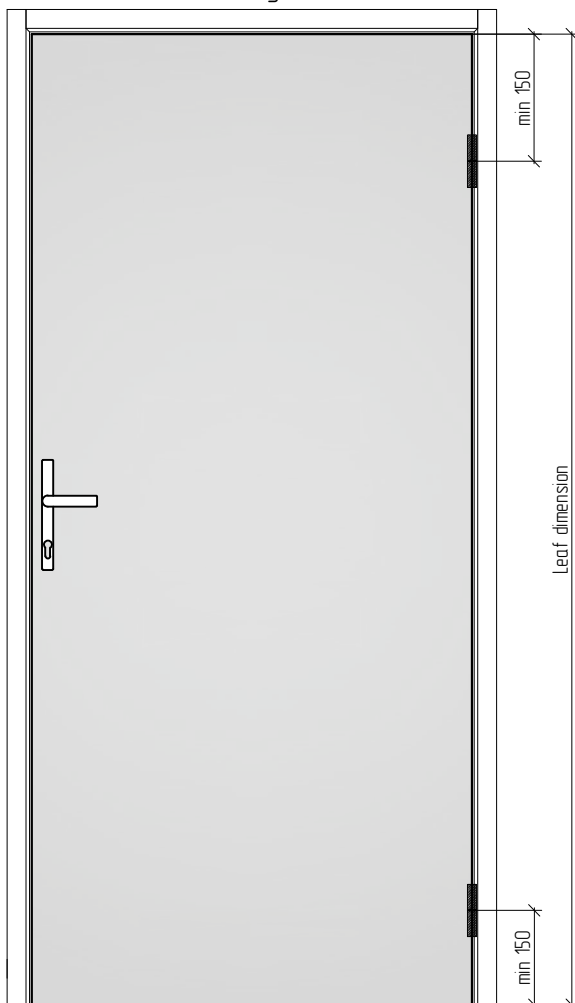

Slim door with AYPC.111.1005 hinges

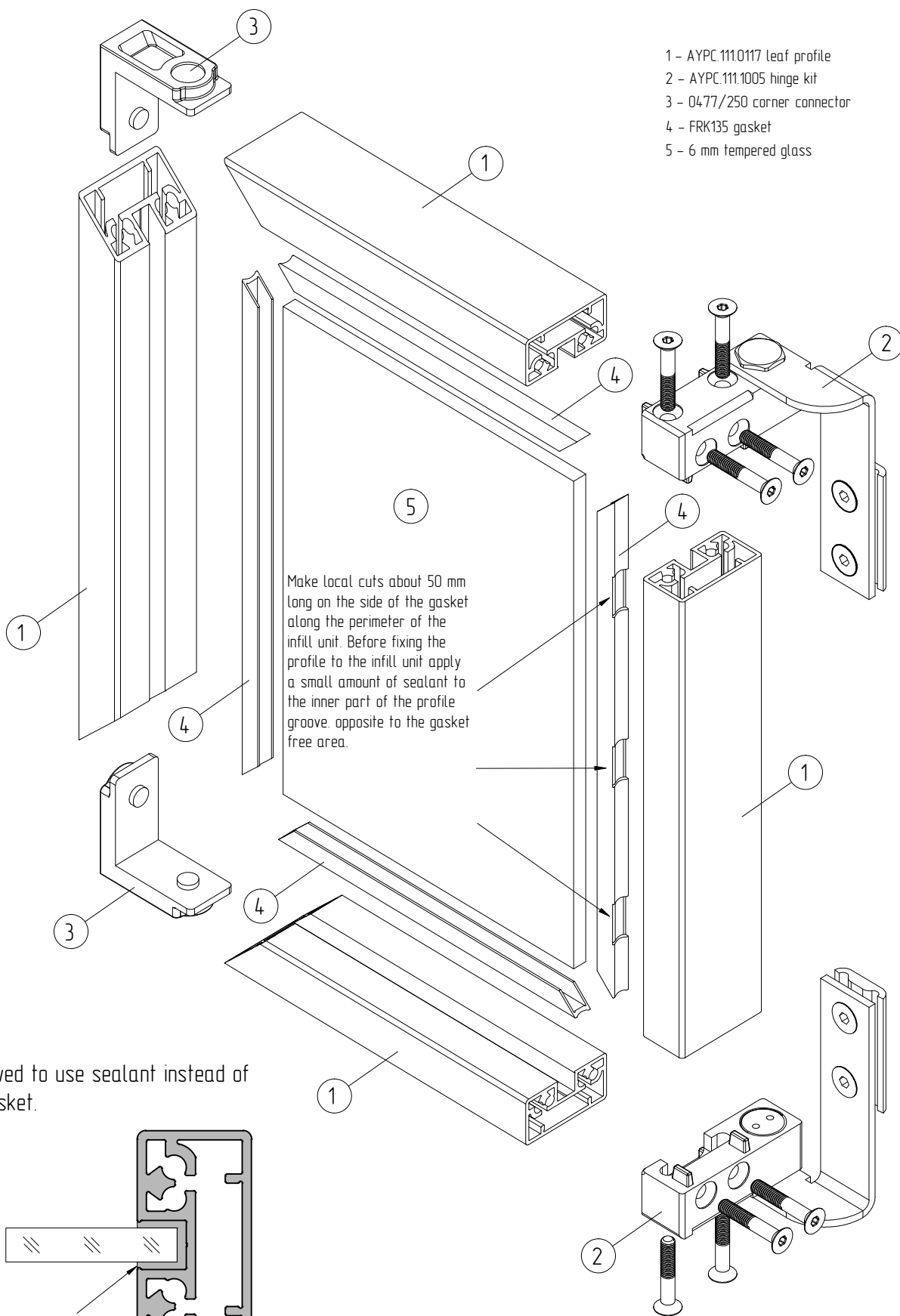

01

02

03

04

05

06

07

08

09

10

11

12

13

14

### Calculation of infill unit dimensions

Door functionality depends on the accuracy of infill unit dimensions, because if its dimensions are out of the tolerance  $\pm 0.1$  mm, the door leaf will sag or it could not be assembled. However, this peculiarity is valid only for the FRK135 rubber gasket. The dimension tolerance could be increased to  $\pm 2.0$  mm with the use of silicone sealant. At the same time the use of gasket makes it possible to replace the damaged glass.

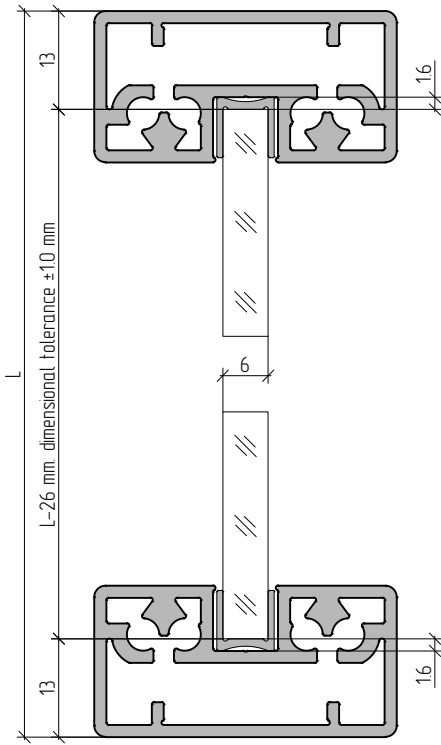

### Calculation of leaf dimensions

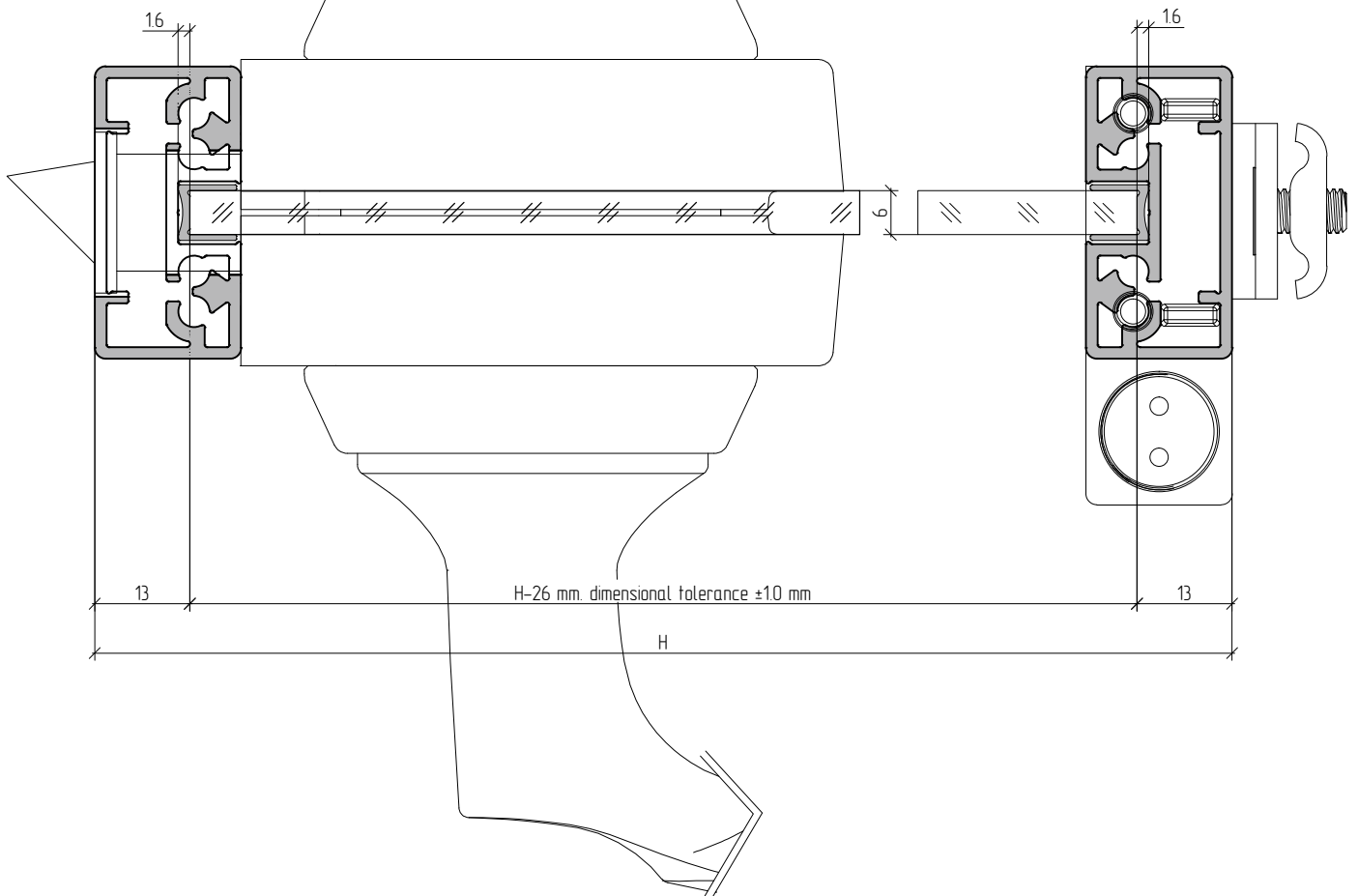
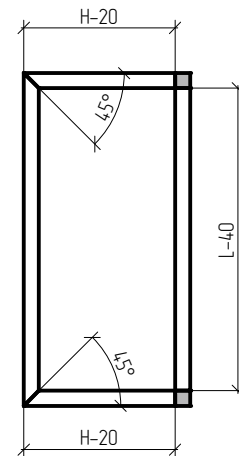



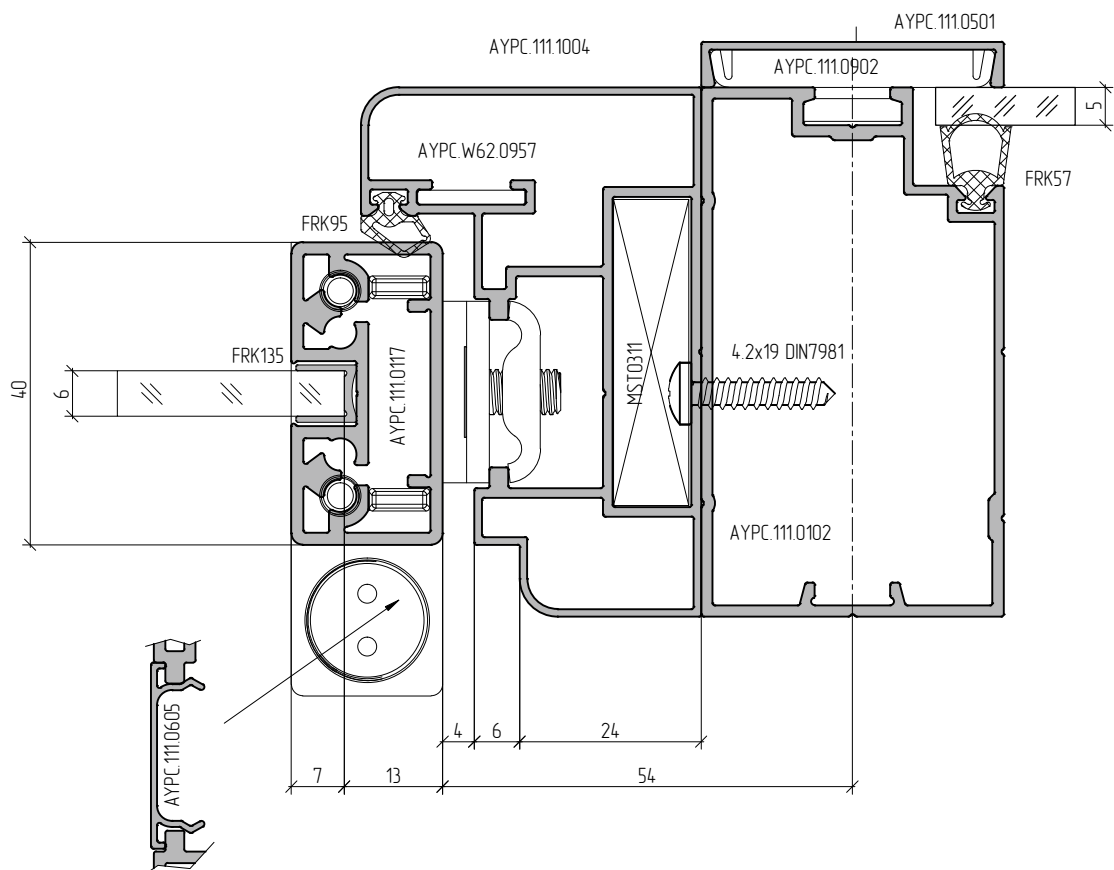
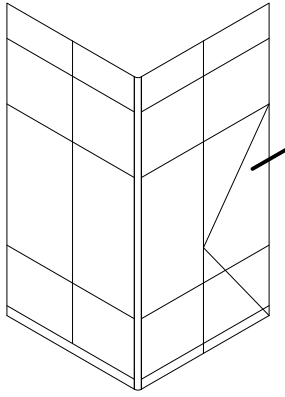

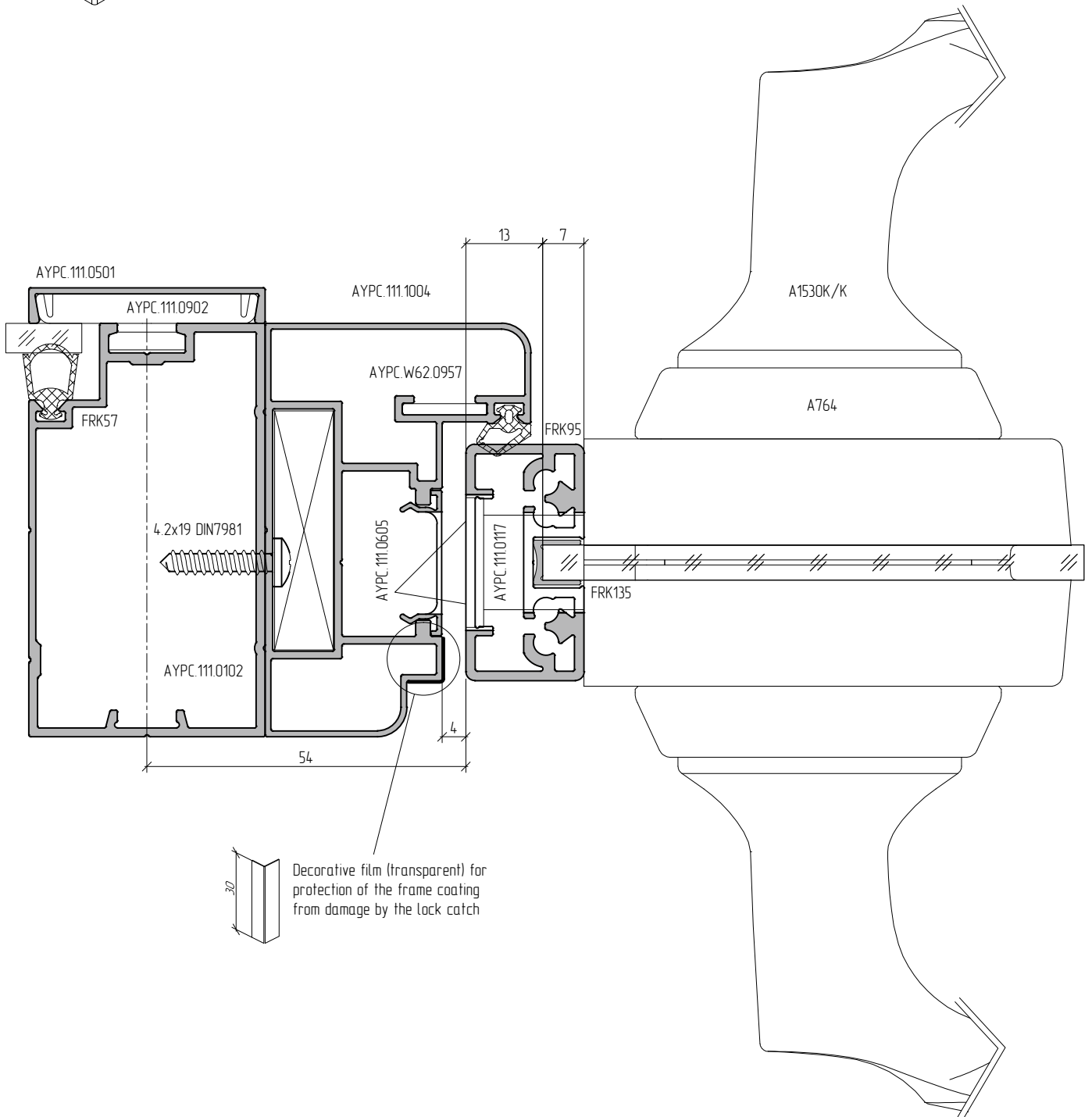
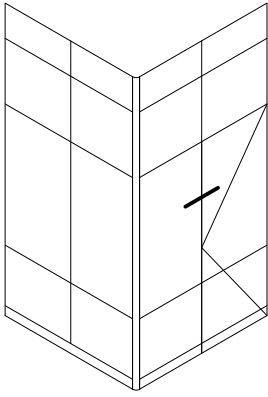

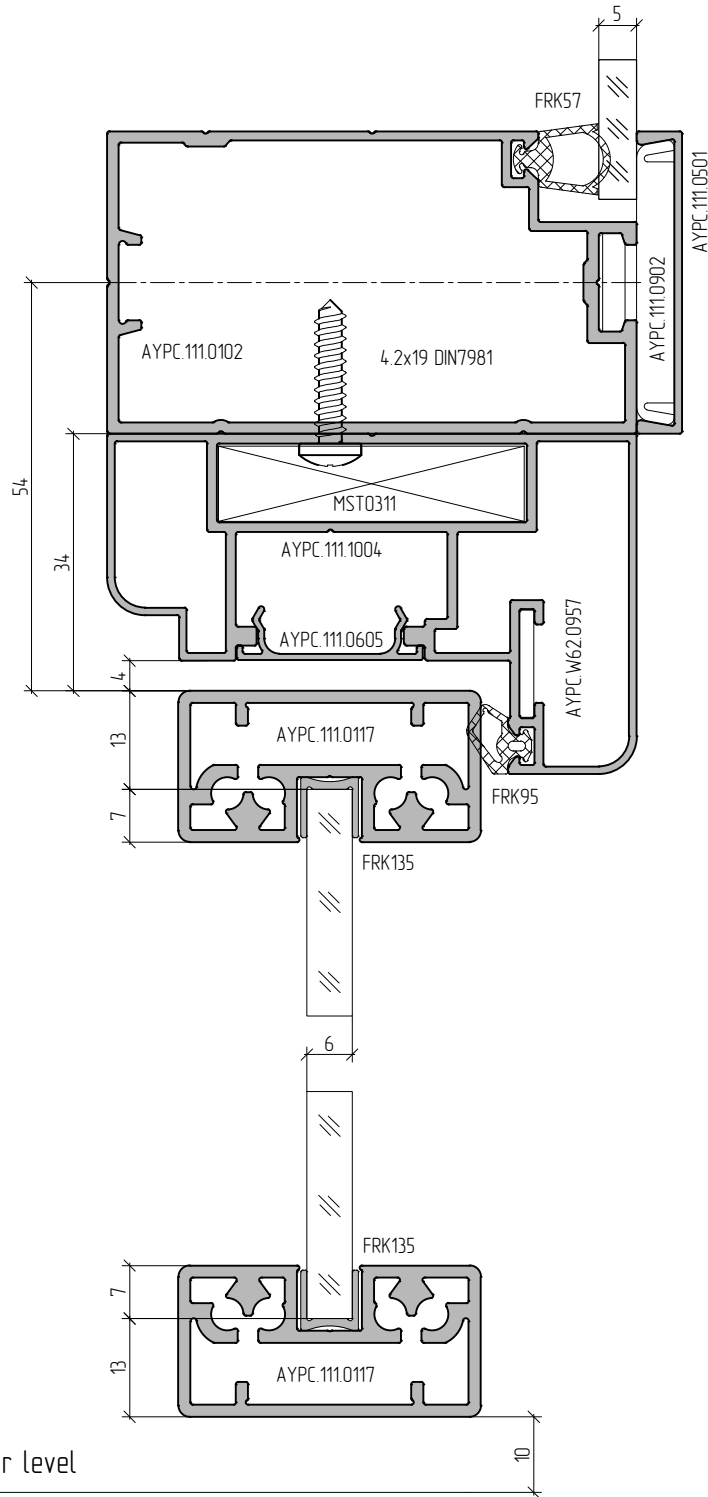
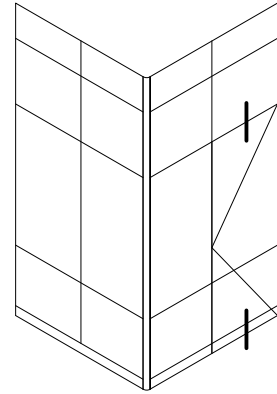

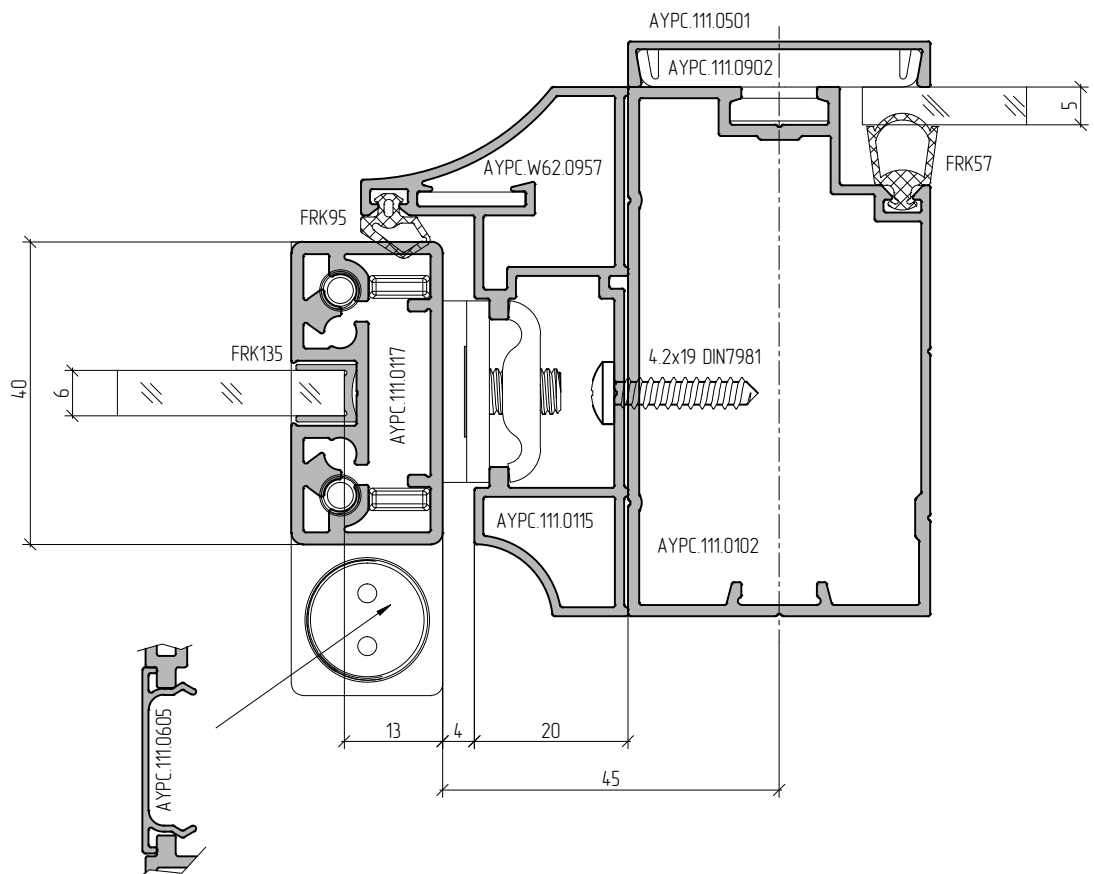
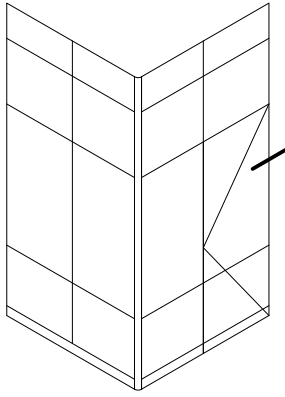

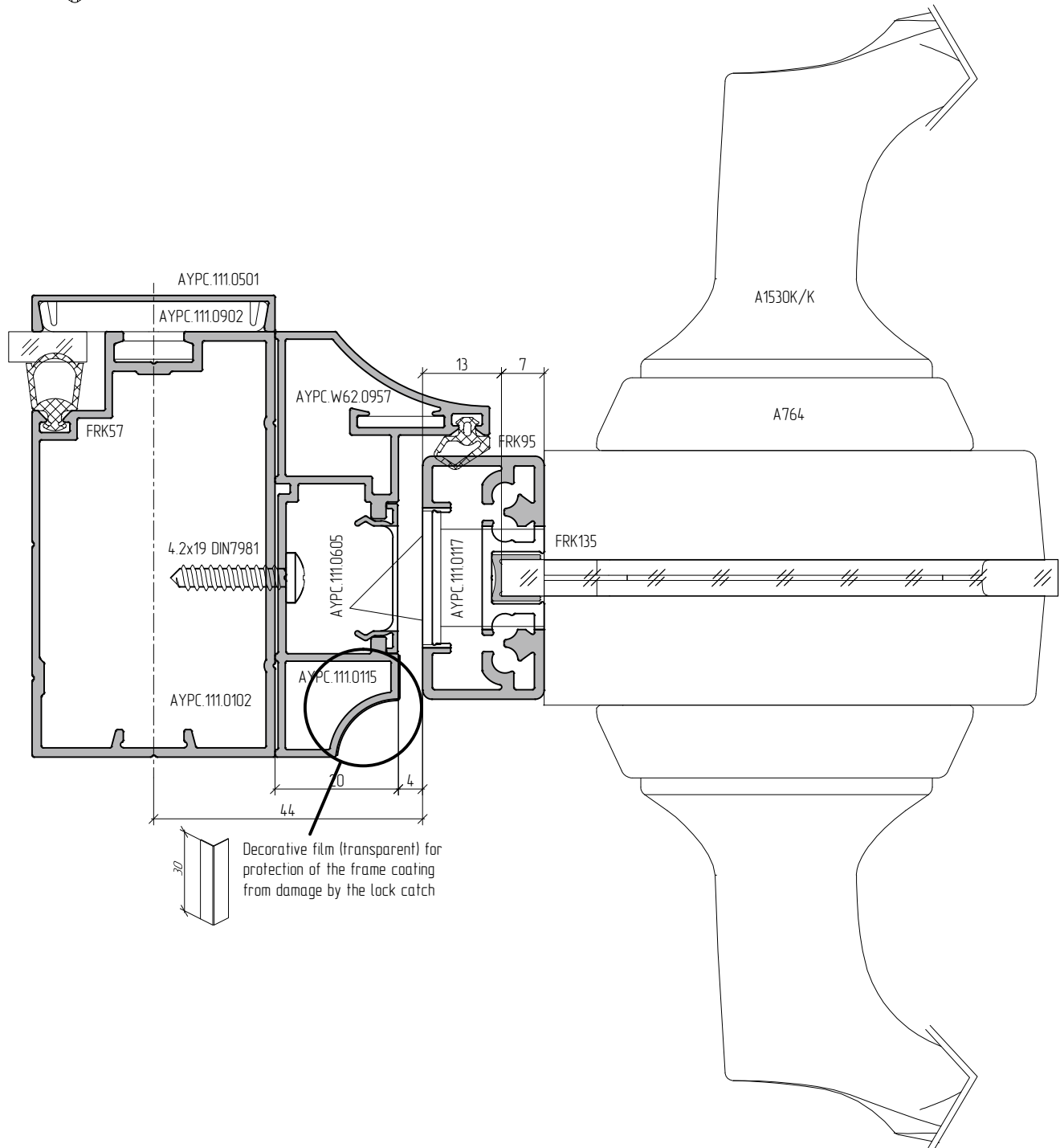
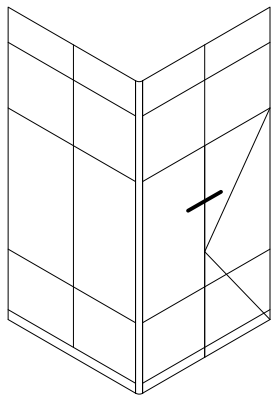

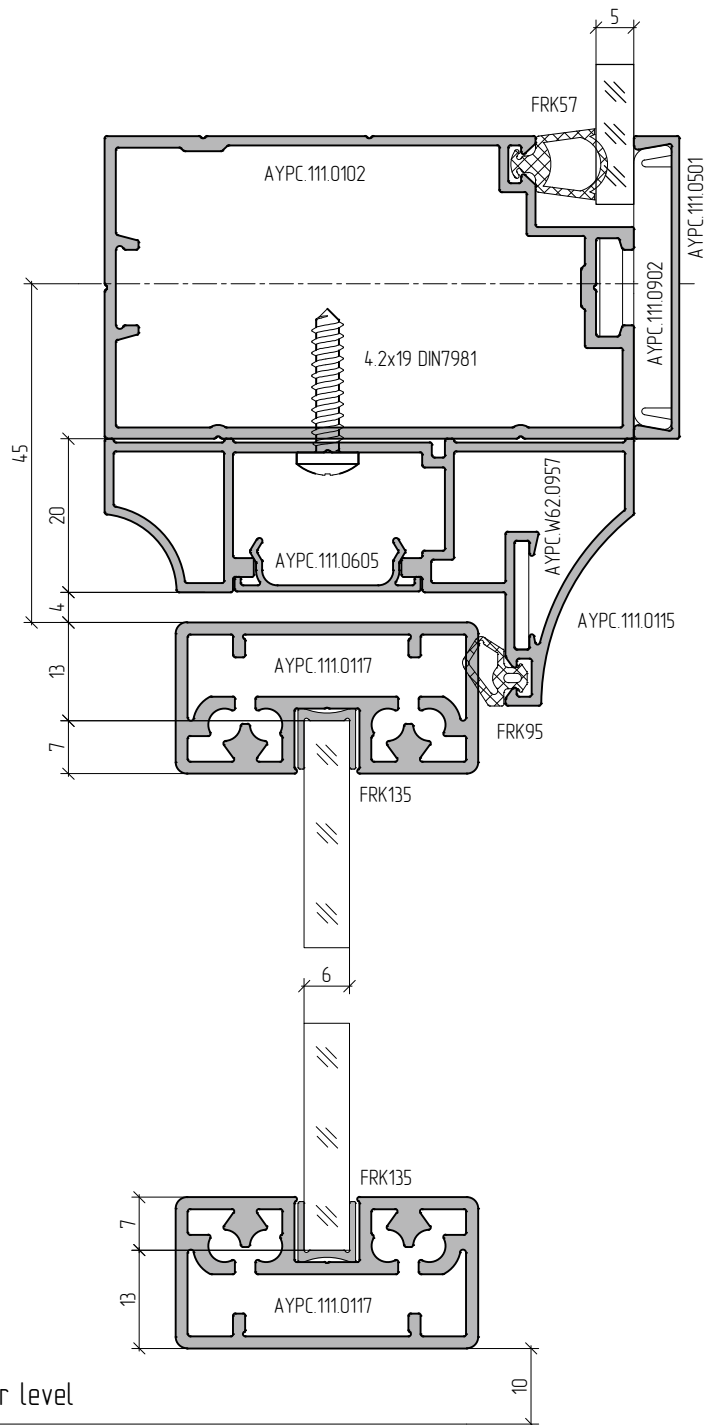
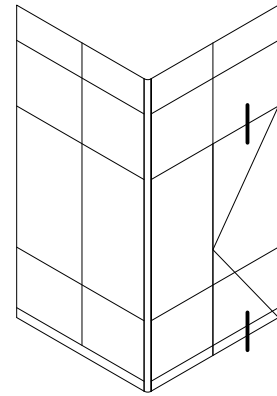

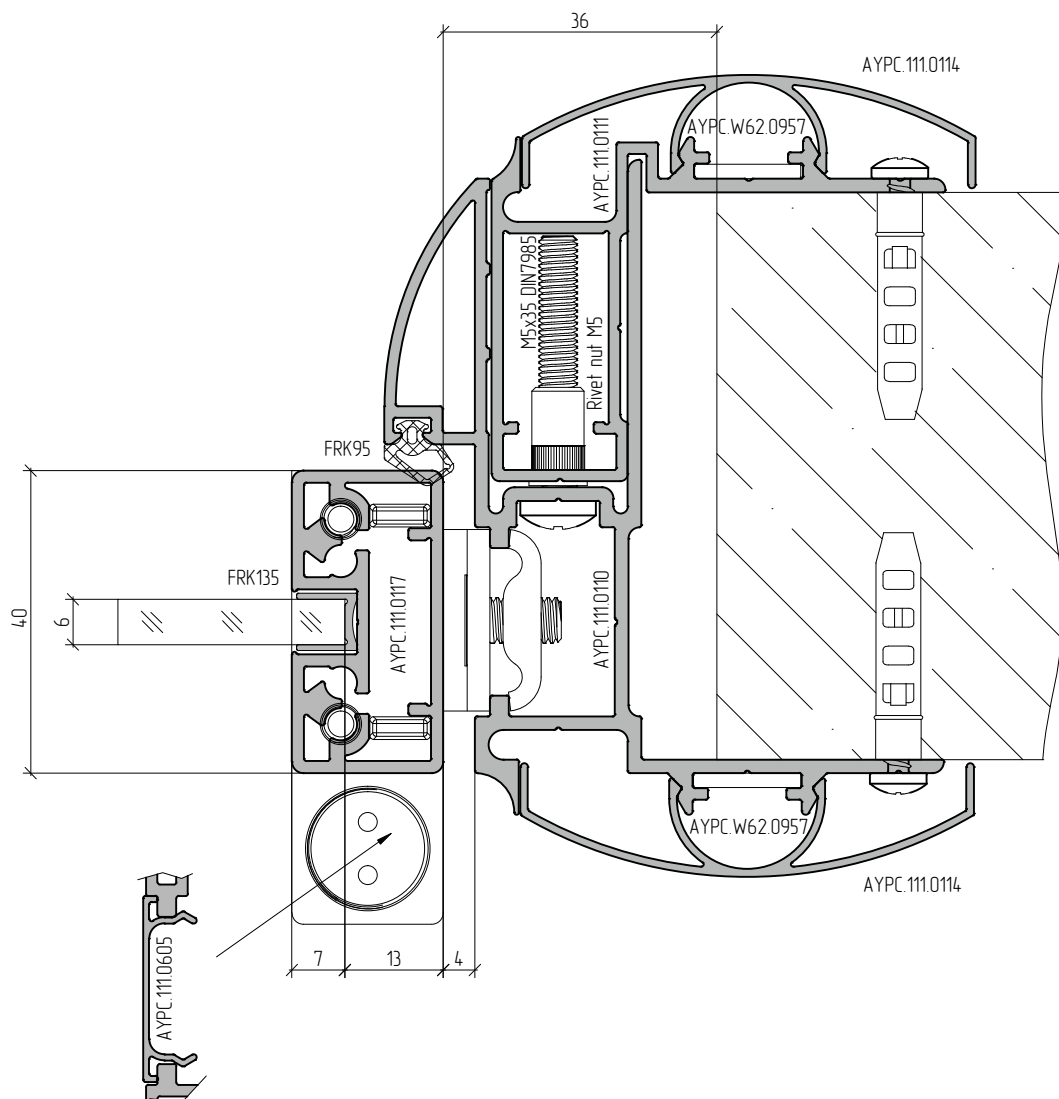
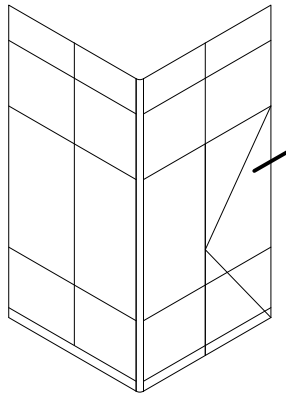

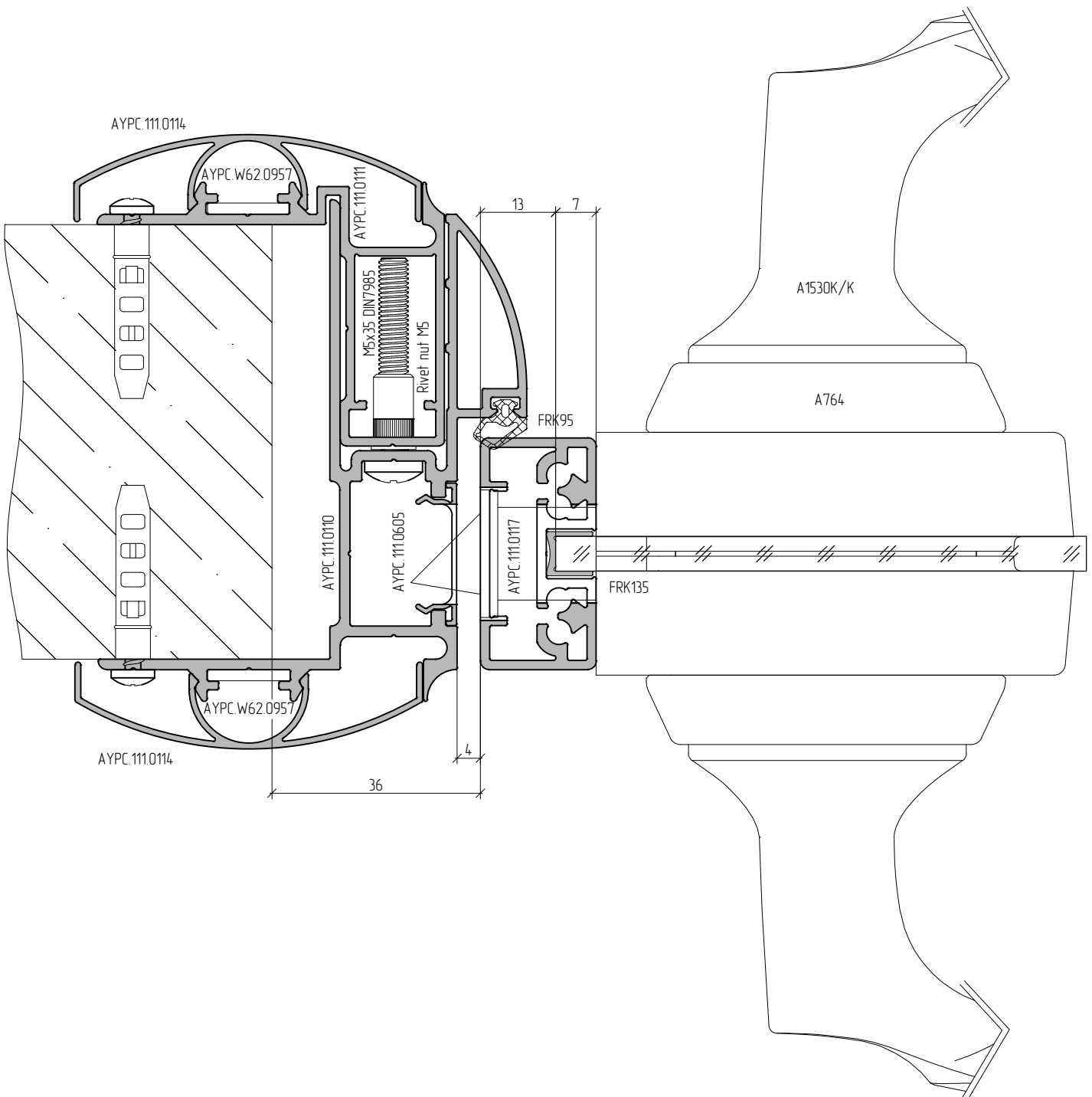
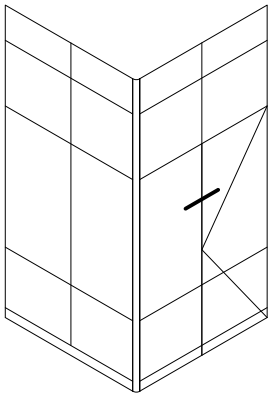



- 01
- 02
- 03
- 04
- 05
- 06
- 07
- 08
- 09
- 10
- 11
- 12
- 13
- 14

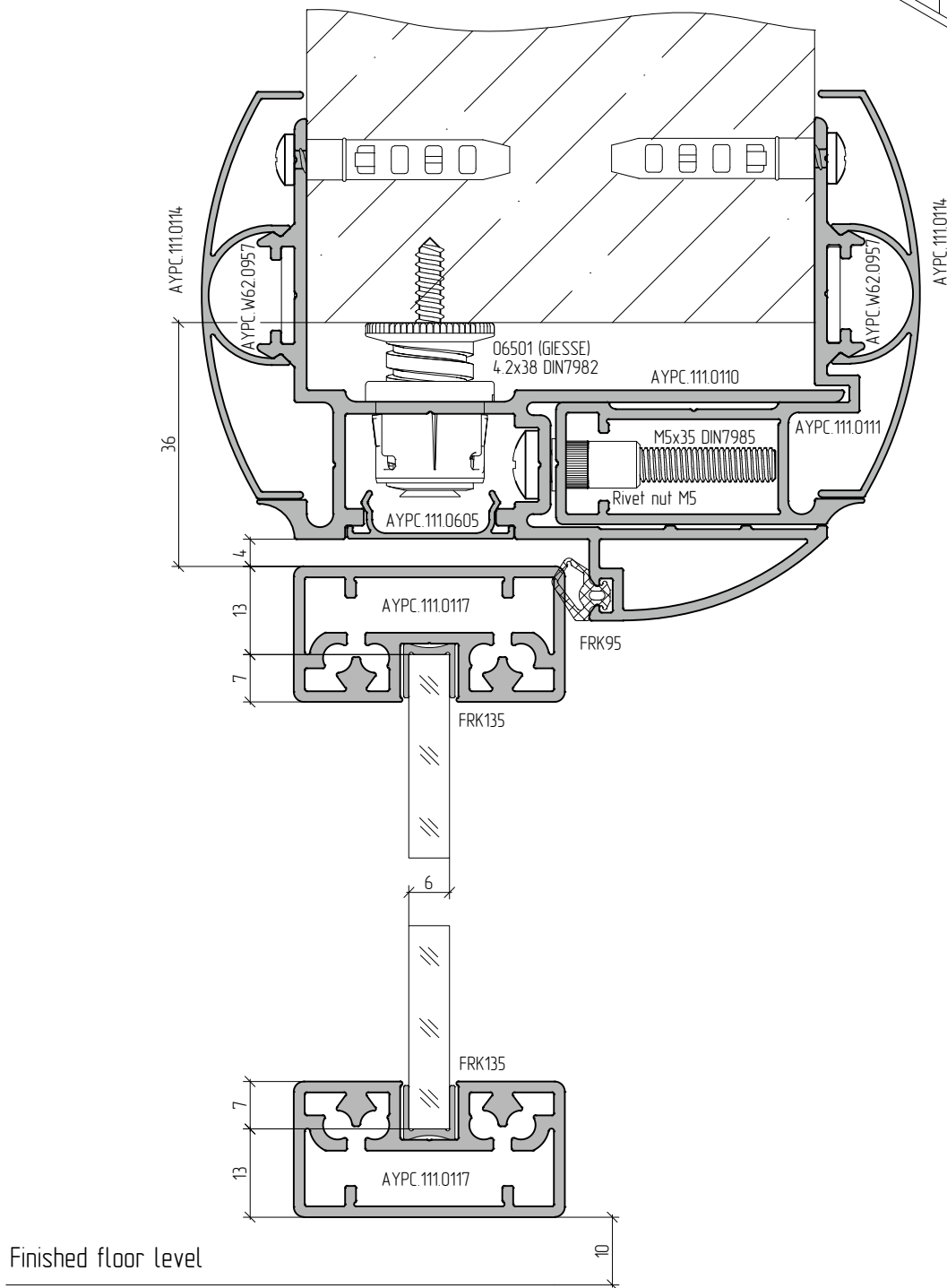
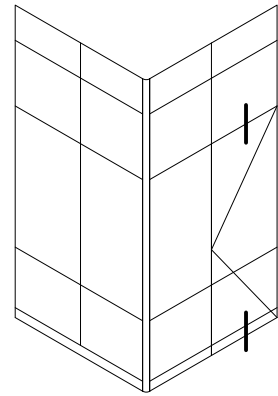

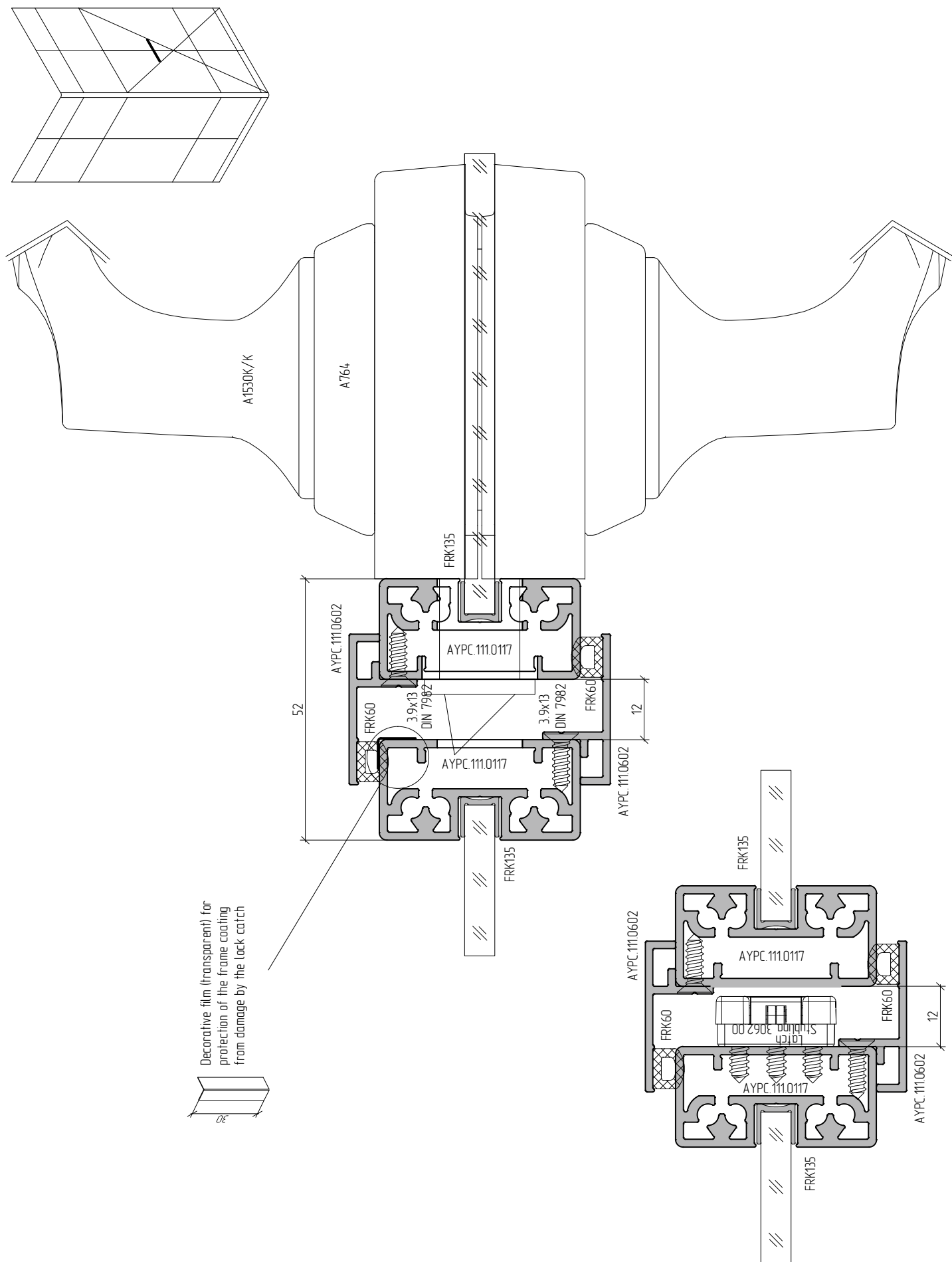



AYPC.111.0117 profile corner connection

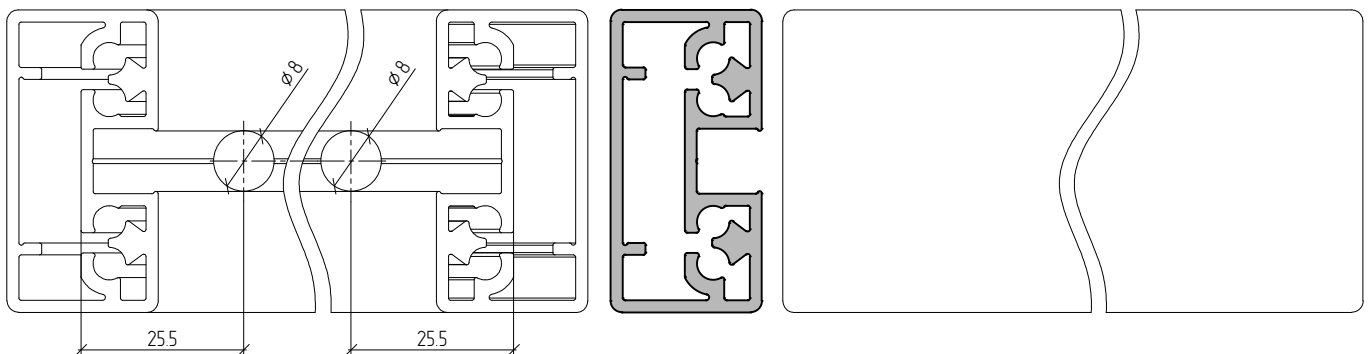
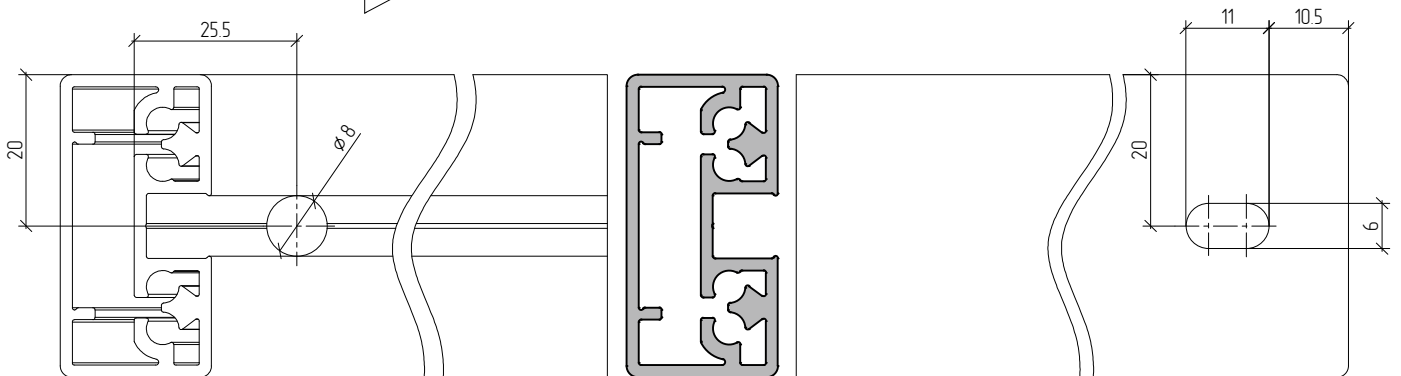
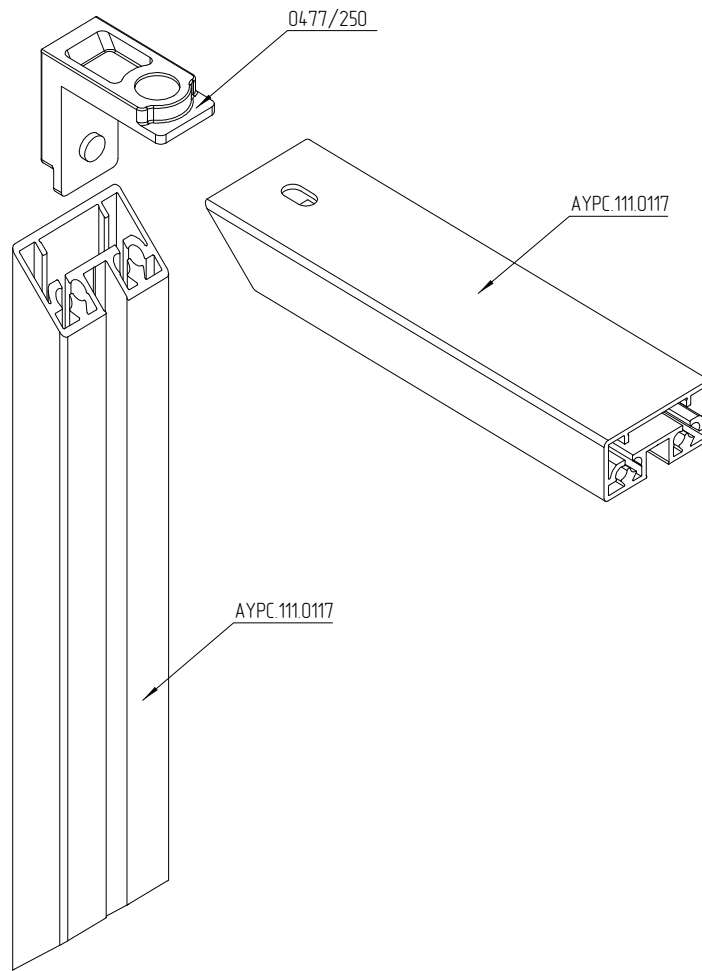

AYPC.111.0117 profile corner connection

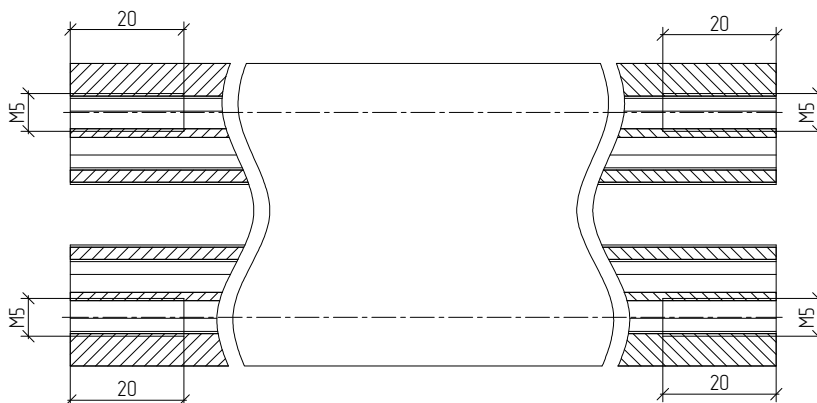
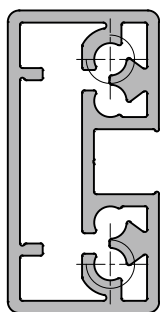
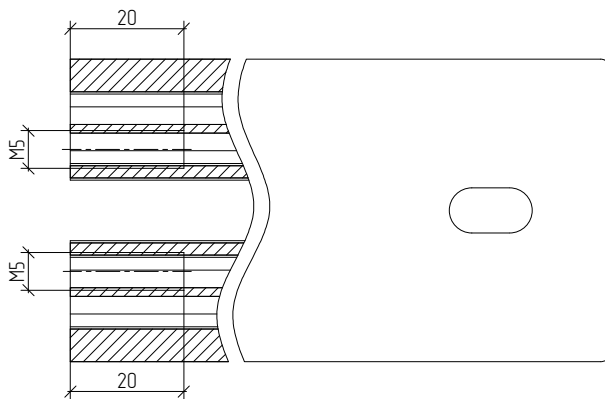
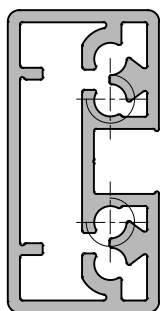
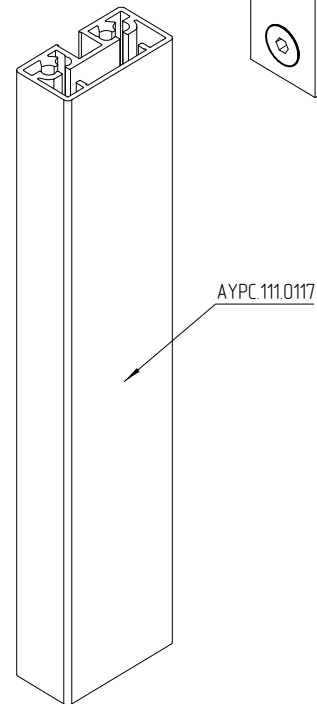
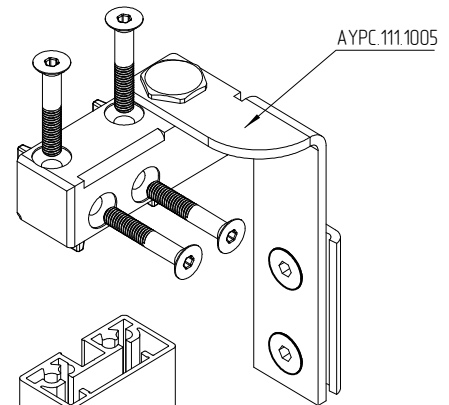
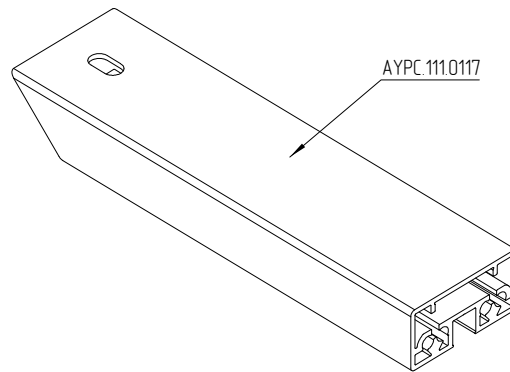

Profile and glass processing for A1530K/K lock installation

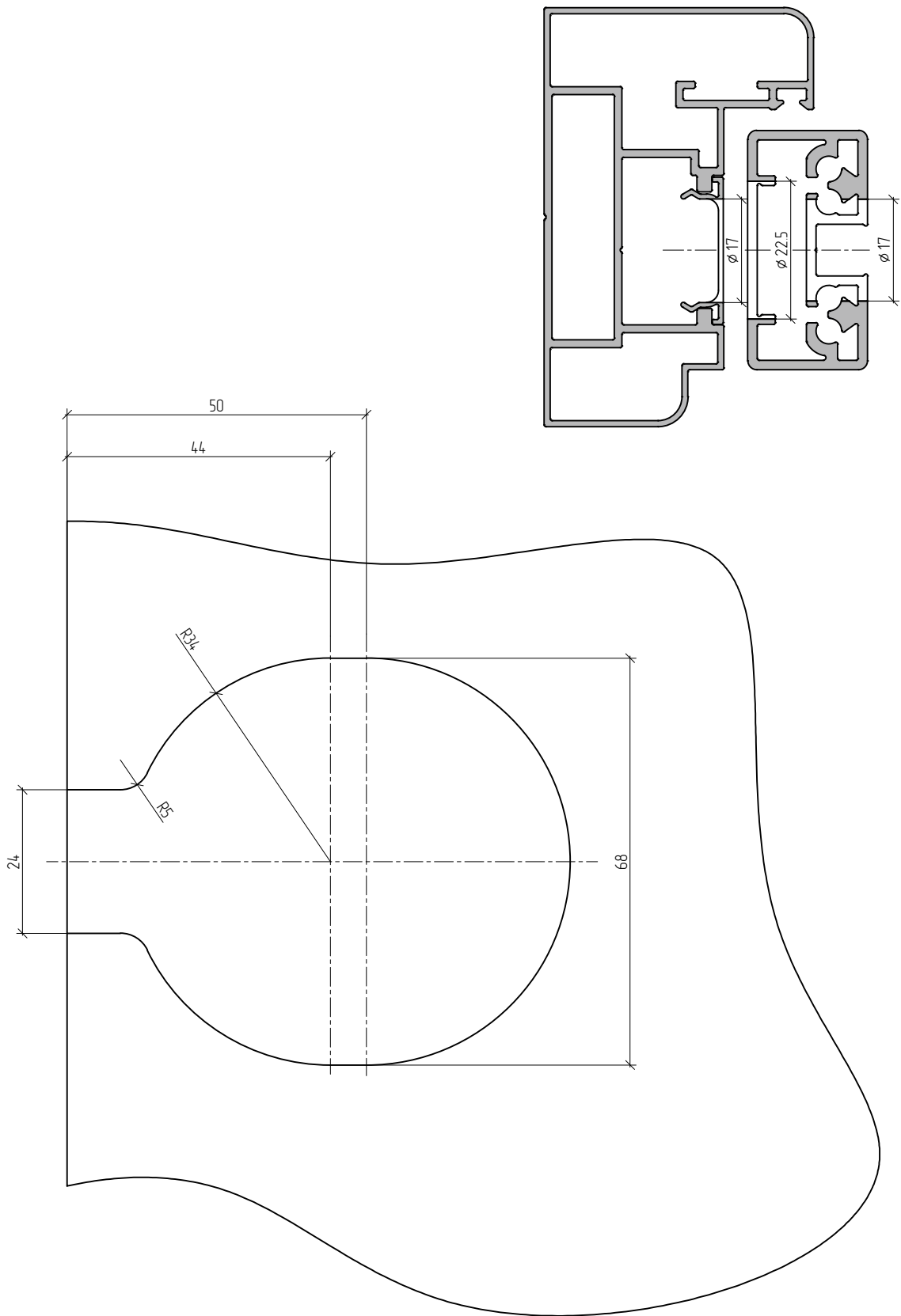

AYPC.111.1005 hinge components

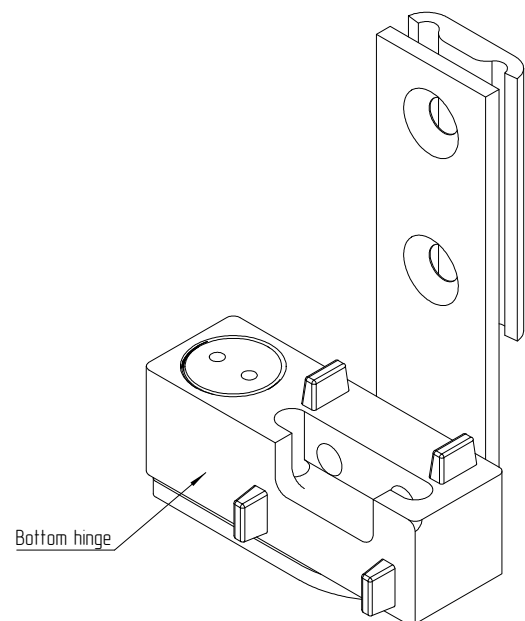
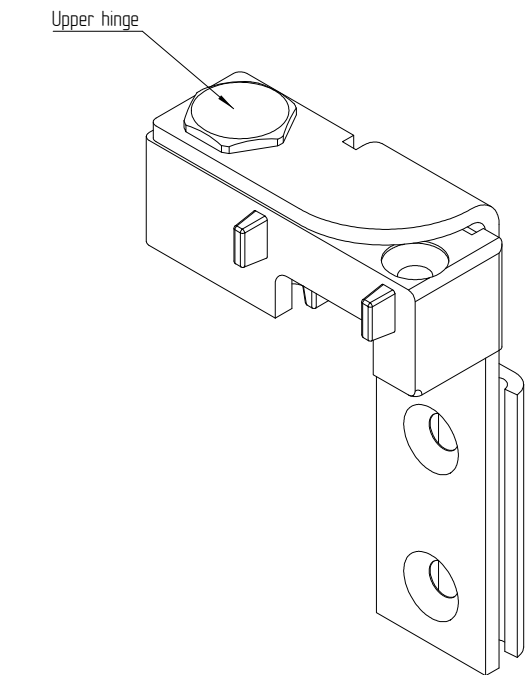
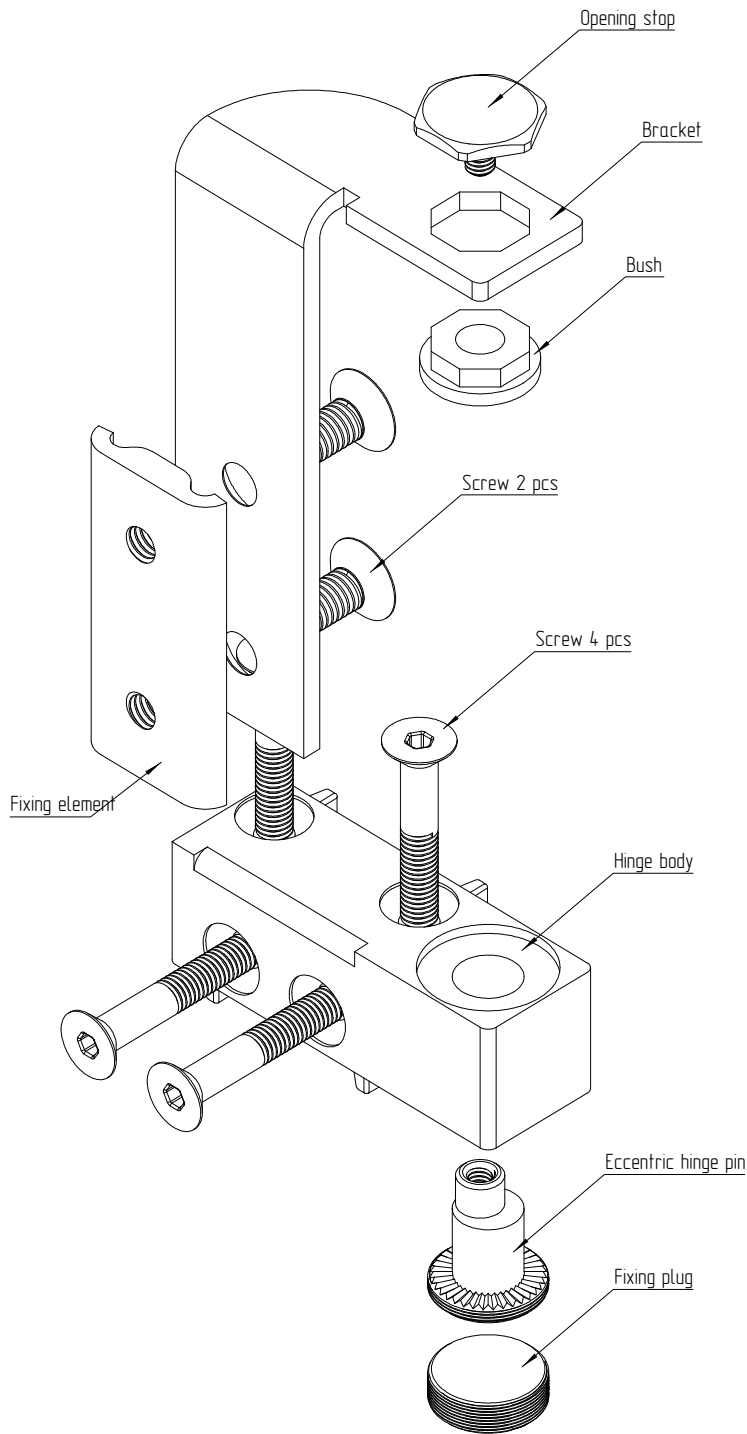

Upper and bottom hinge bodies as well as brackets are installed in inversed manner.

Reinforced double-glazed door

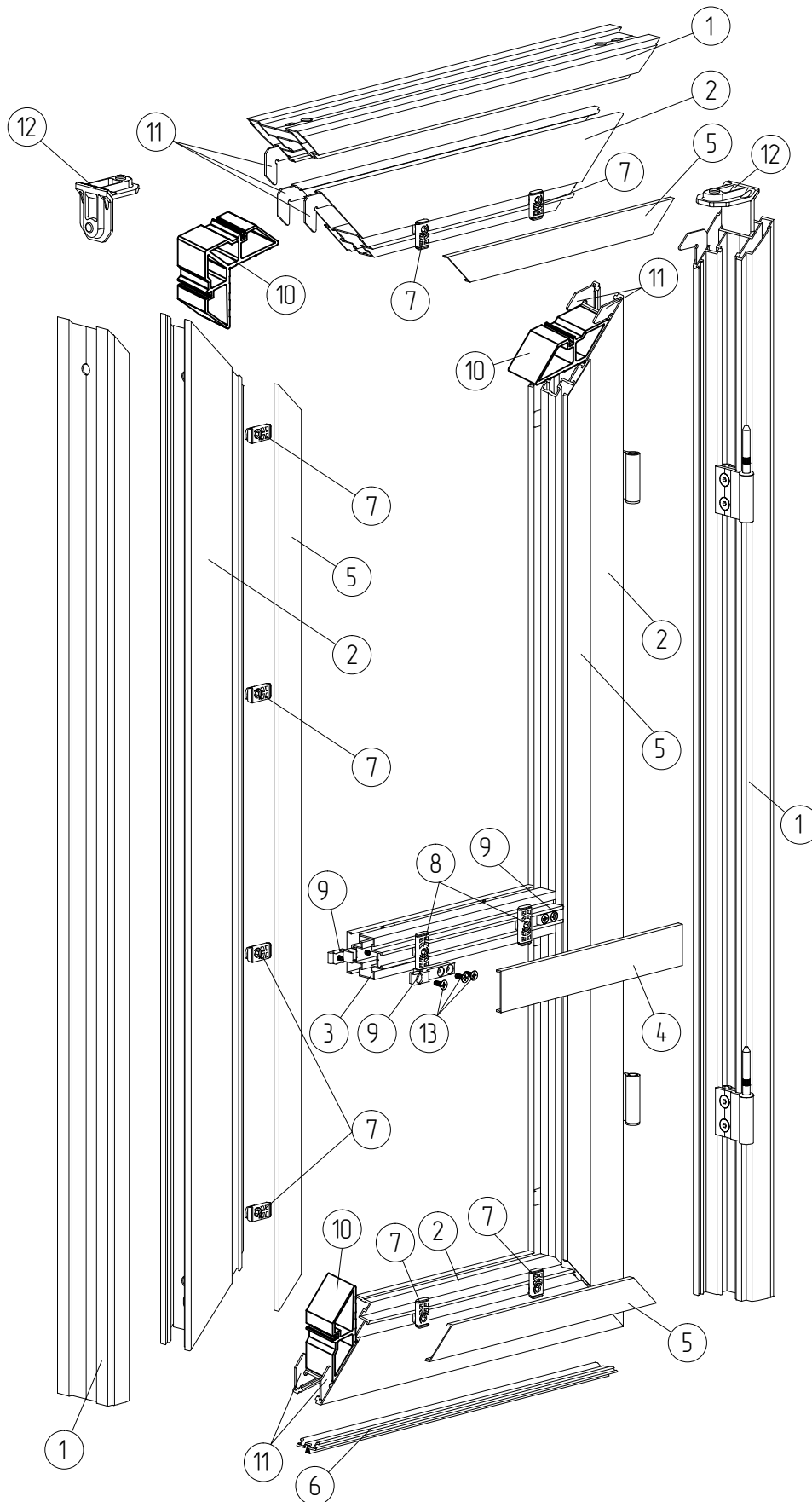

- 1 - AYPC.111.0107 door frame
- 2 - AYPC.111.0106M door leaf
- 3 - AYPC.111.0203 door transom
- 4 - AYPC.111.0501 cover profile
- 5 - AYPC.111.0502 cover profile
- 6 - AYPC.111.0601 door holder
- 7 - AYPC.111.0901 clamp
- 8 - AYPC.111.0902 clamp
- 9 - AYPC.111.0952 bracket
- 10 - AYPC.111.0958 clamping corner
- 11 - AYPC.W62.0957 leveling corner
- 12 - MST0311 connection corner
- 13 - 4.2x13 DIN7982 self-tapping screw



AYPC.111.0106M leaves corner connection on pins

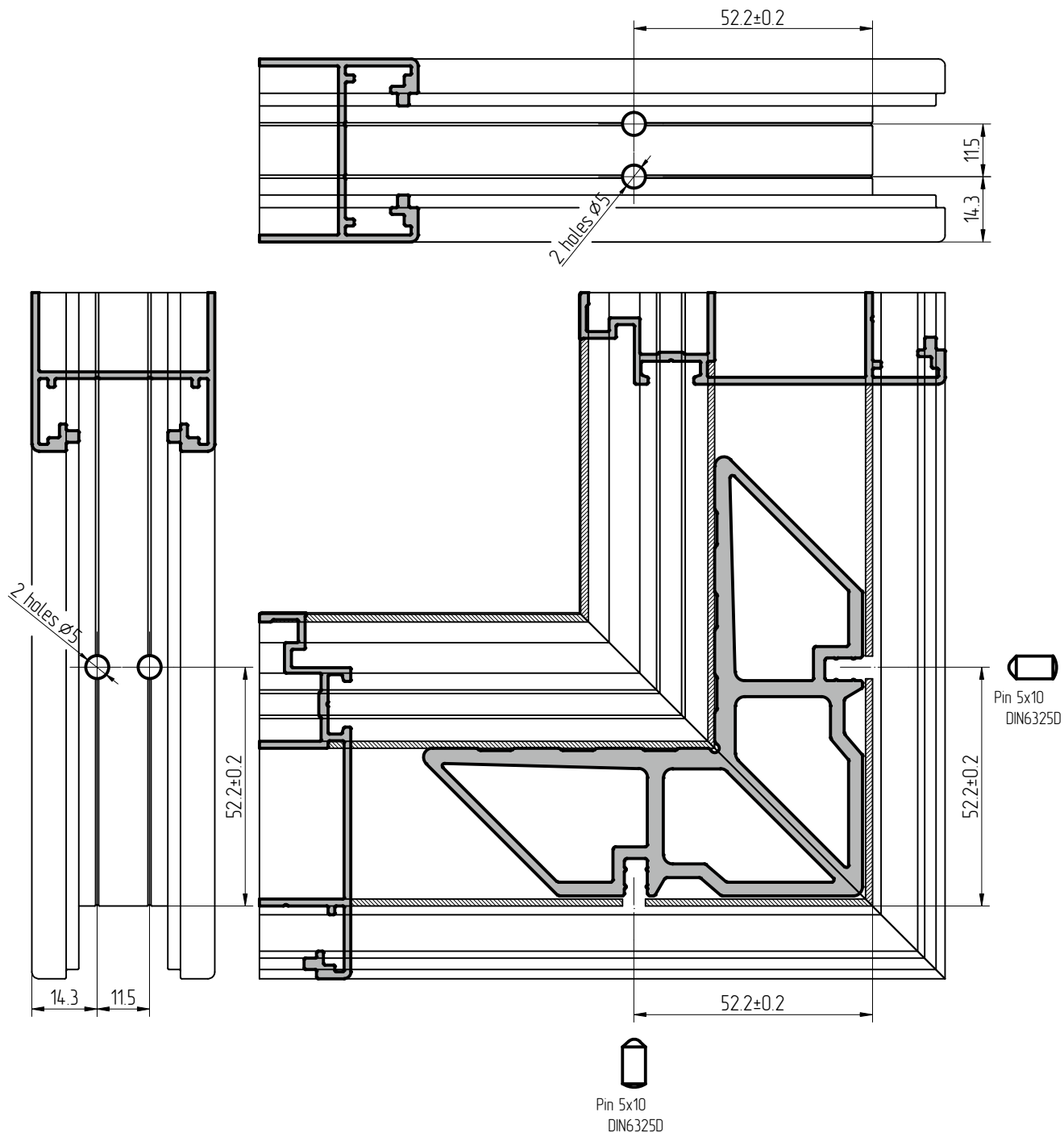

Fill the profile chamber with the glue before clamping corner installation.  
Apply the glue to clamping corner surface as well.





**ALUTECH ALT 111**  
Interior partition system

# Top hung sliding door

01

02

03

04

05

06

07

08

09

10

**11**

12

13

14



## TOP HUNG SLIDING DOOR

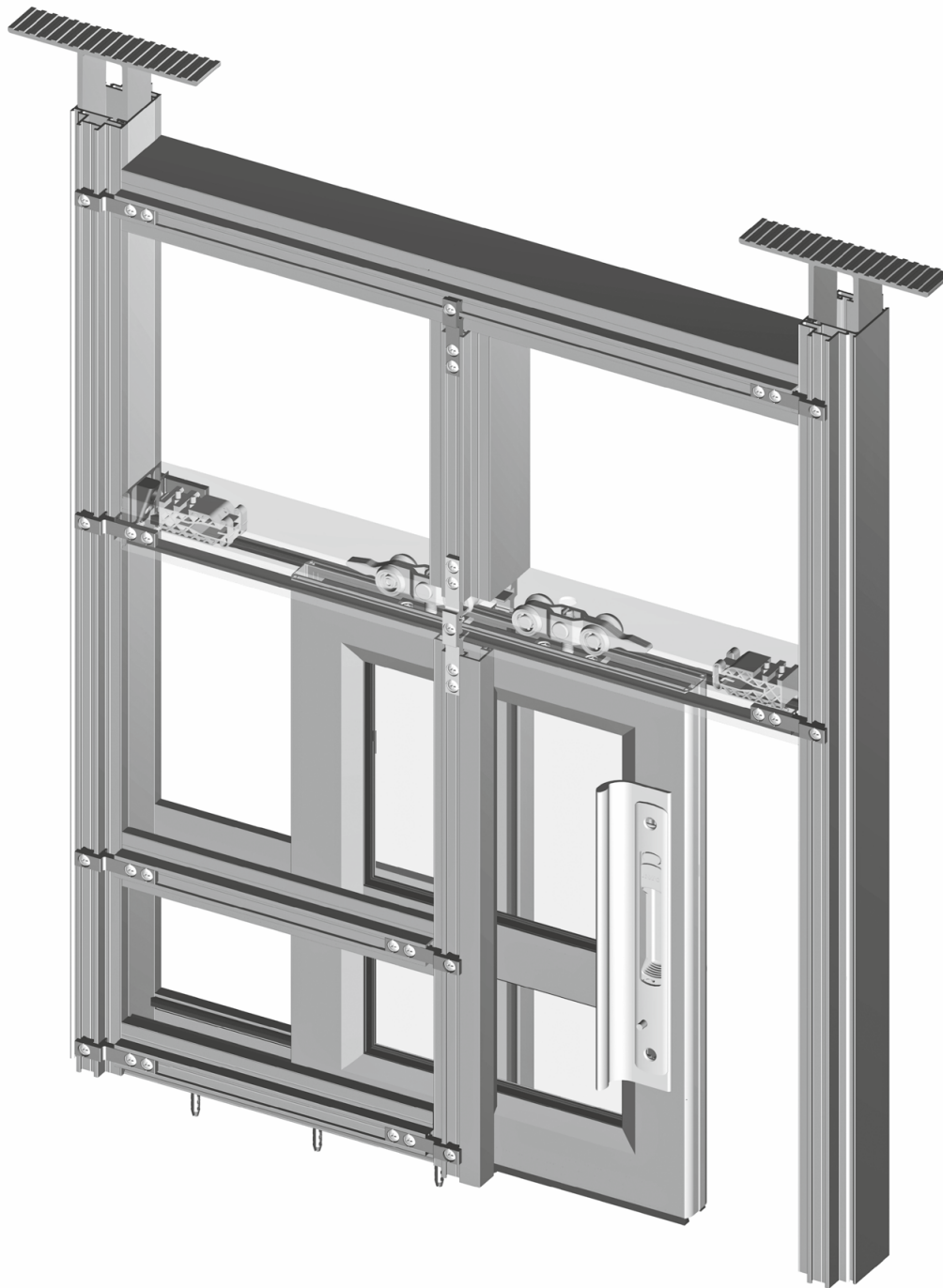

Fig.1

The sliding door is designed as part of the ALT111 interior partition system. The system design allows the top hung door to slide inside of the partition between two panes of glass.

Special mullions and transoms of the same appearance with ALT111 profiles are creating the framework for sliding door installation and have the groove for brackets and glass fixing elements installation.

## Framework assembly for sliding door installation

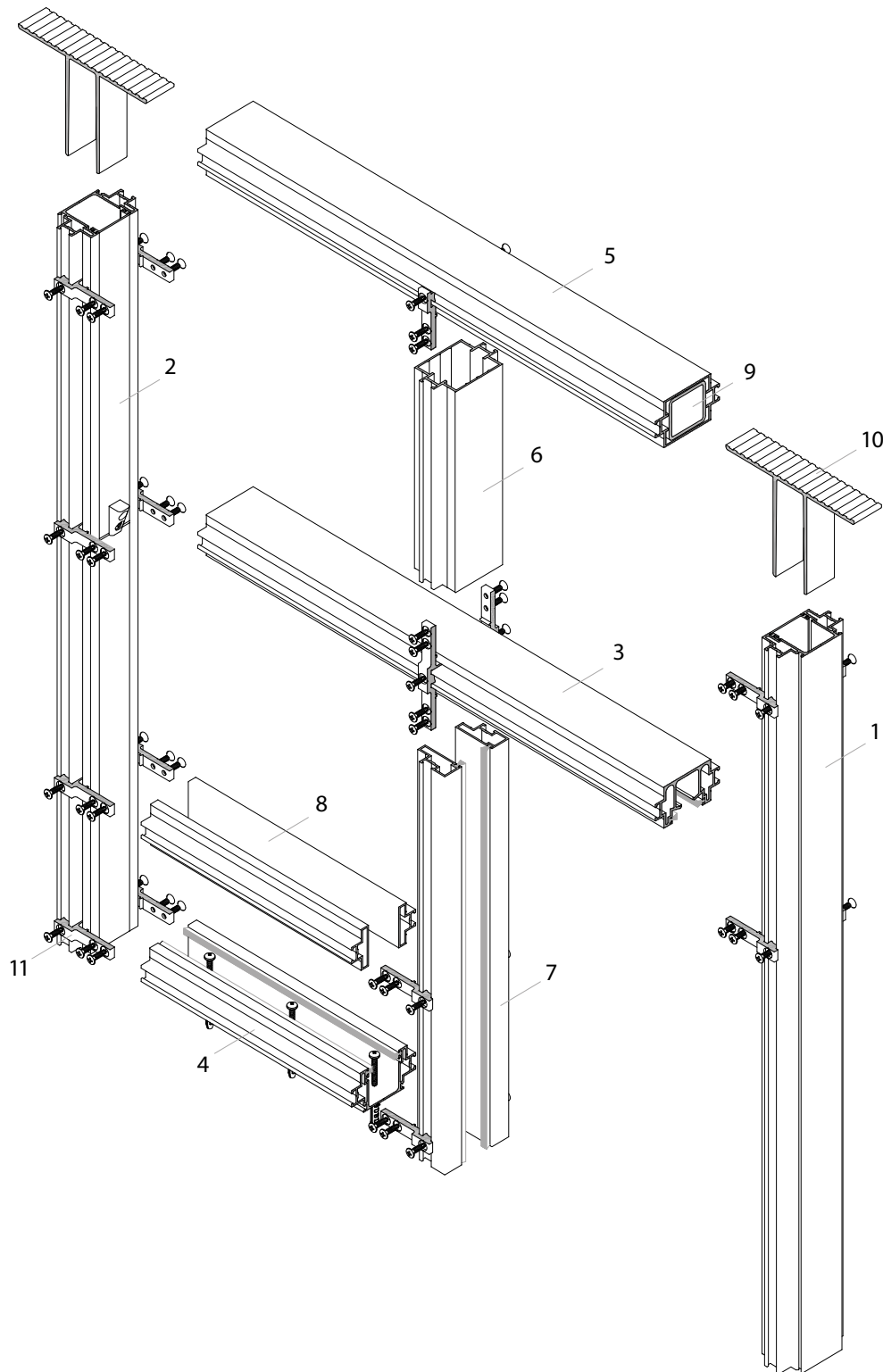

Fig.2

The sliding door framework is created by the combined vertical mullions Pos. 1 and 2 on Fig. 2. The mullions can be fixed to the upper slab through joining elements (Pos. 10) creating a movable bearing together with the inner chamber of the mullion profile. This movable bearing allows to compensate the thermal expansion of the aluminium profile and deflection of the upper floor slab.

The combined mullions are assembled in advance according to the measurements made (Fig. 3). Left mullion on Fig. 3 is the Pos. 2 on Fig. 2, right mullion on Fig. 3 is the Pos. 1 on Fig. 2.

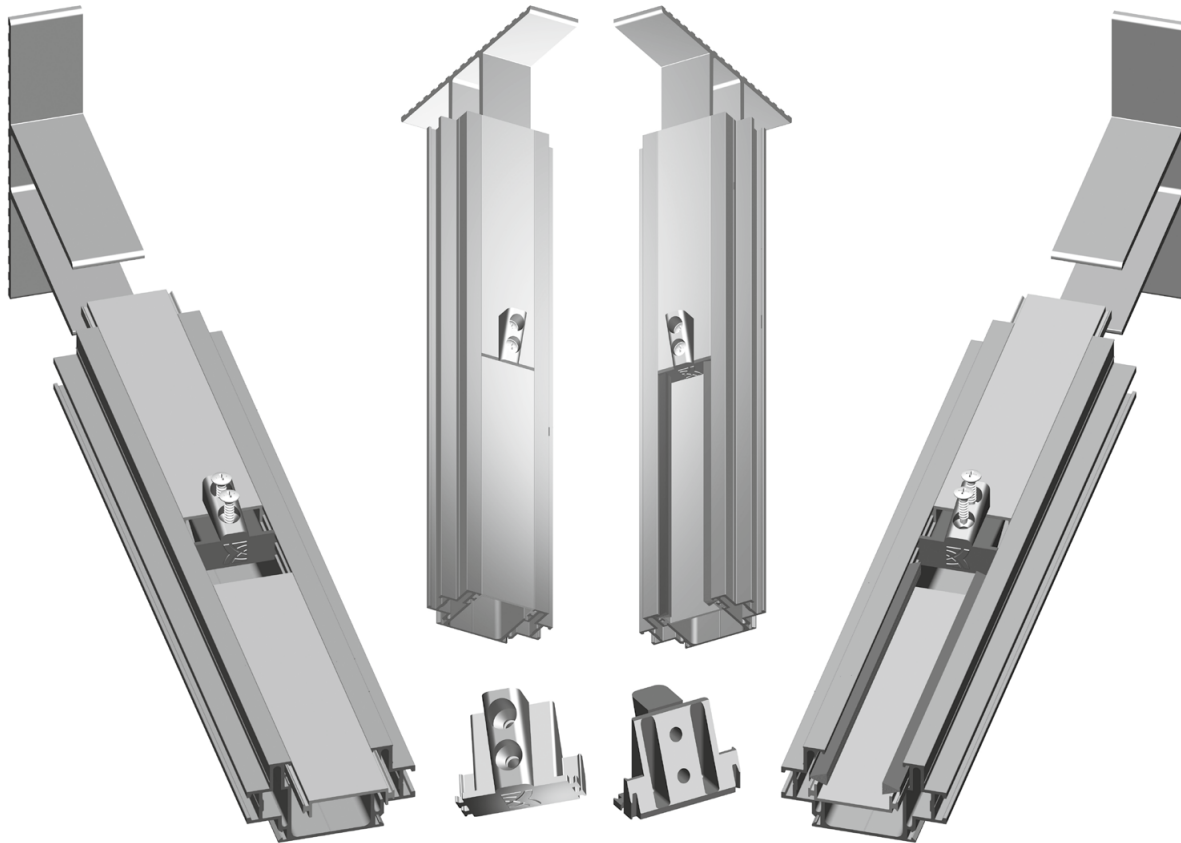

Fig.3

The main mullion profile is the profile *a*) on Fig. 4. The auxiliary profile *b*) is installed into this profile depending on the functionality required.

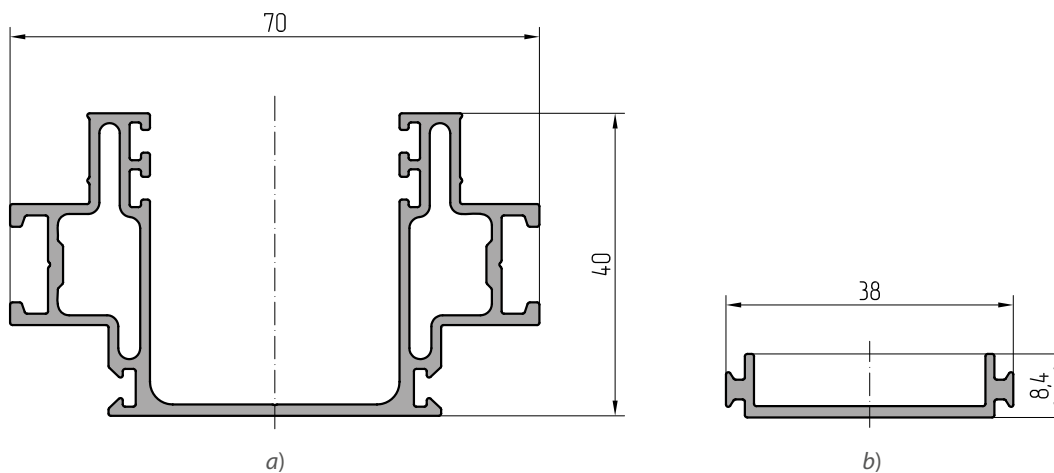

Fig.4

The right mullion is used as a catch in the door installation area, and it repeats the external geometry of other ALT111 profiles in the area of glass installation. This is achieved by the auxiliary profile segments which are placed into the mullion from both sides turned around 180° to each other. The gap between the profiles is covered with a plastic plug as shown on Fig. 3.

The left mullion consists of the initial profile and auxiliary profile segments joined with the same plastic plug.

The plug also performs a function of a bearing support for guide transom installation (Fig. 5).

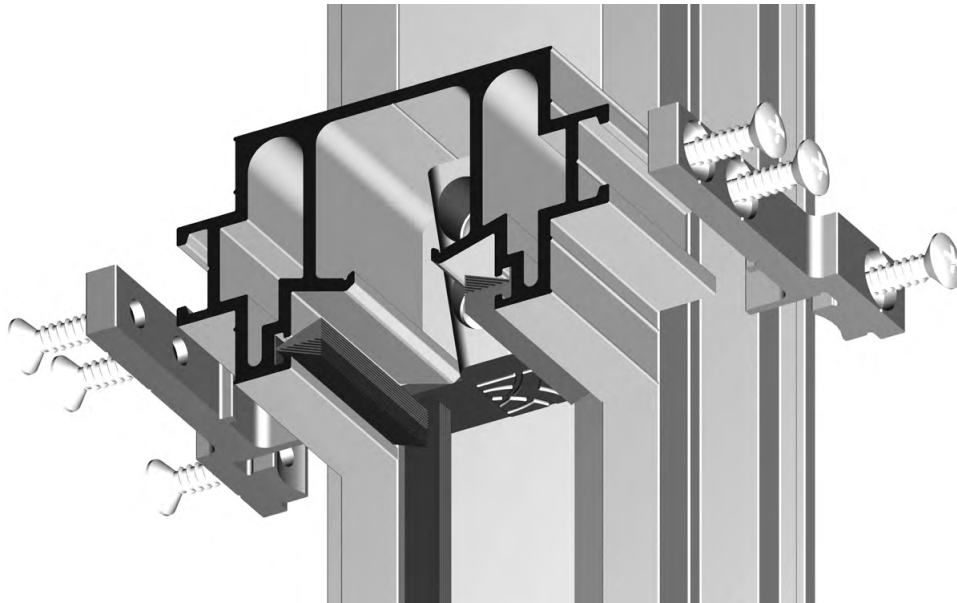

Fig.5

The guide transom (Pos. 3 on Fig. 2) is shown on Fig. 6. It has a shape allowing to put rollers and door stops. The felt sealants between the guide transom and the door leaf are hiding the gap and protecting the hardware from dust penetration.

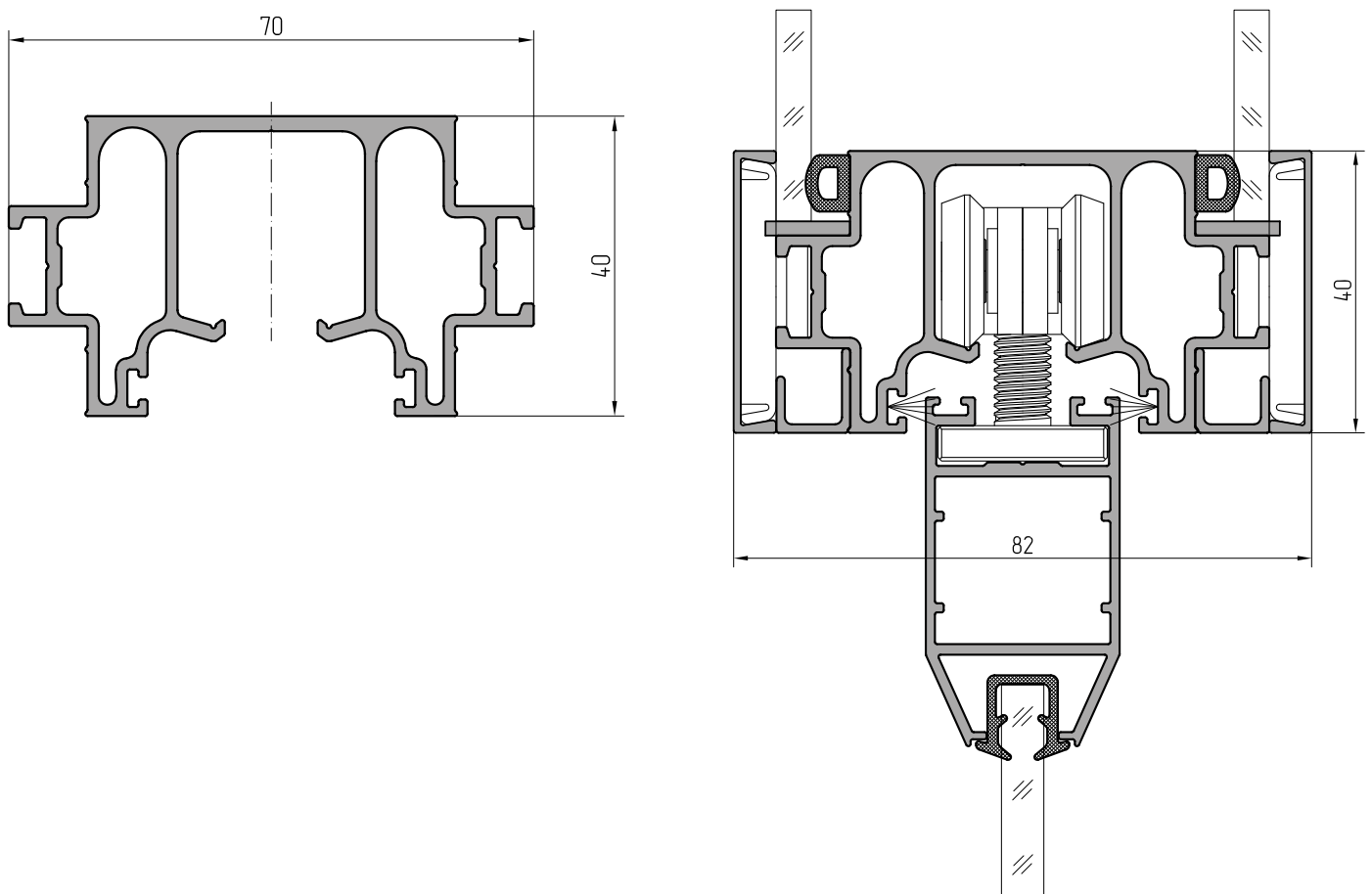

Fig.6

Bottom guide profile (Pos. 4 on Fig. 2) is the same shape than the side door frames. The felt sealant on the bottom guide is hiding the gap between the door leaf and the aluminium profile (Fig. 7). The bottom guide is fixed to the floor.



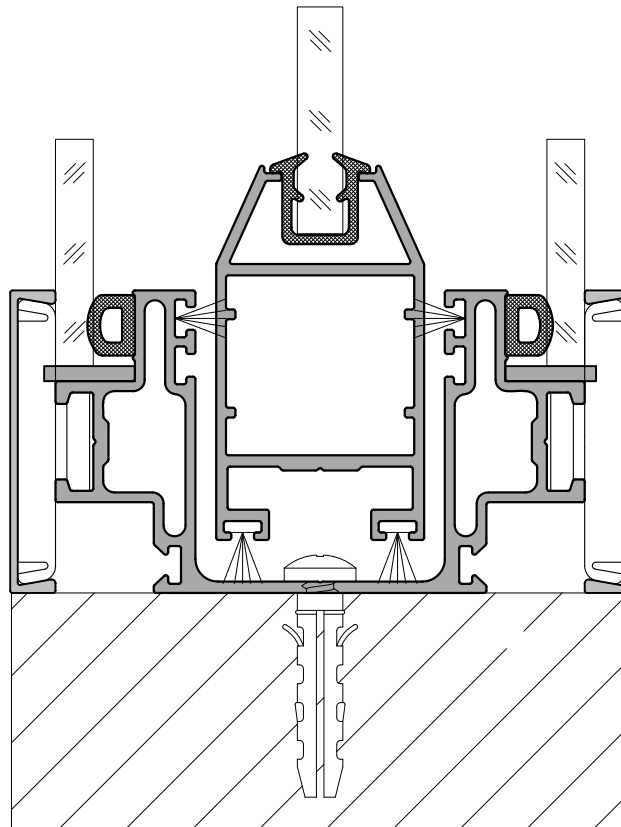

Fig.7

The upper reinforced transom bar is shown on Fig. 2 (Pos. 5). It can be reinforced depending on the opening width and the door leaf weight by 40×40 mm steel tube (Fig. 2, Pos. 9) with wall thickness of 3 mm (Fig. 8).

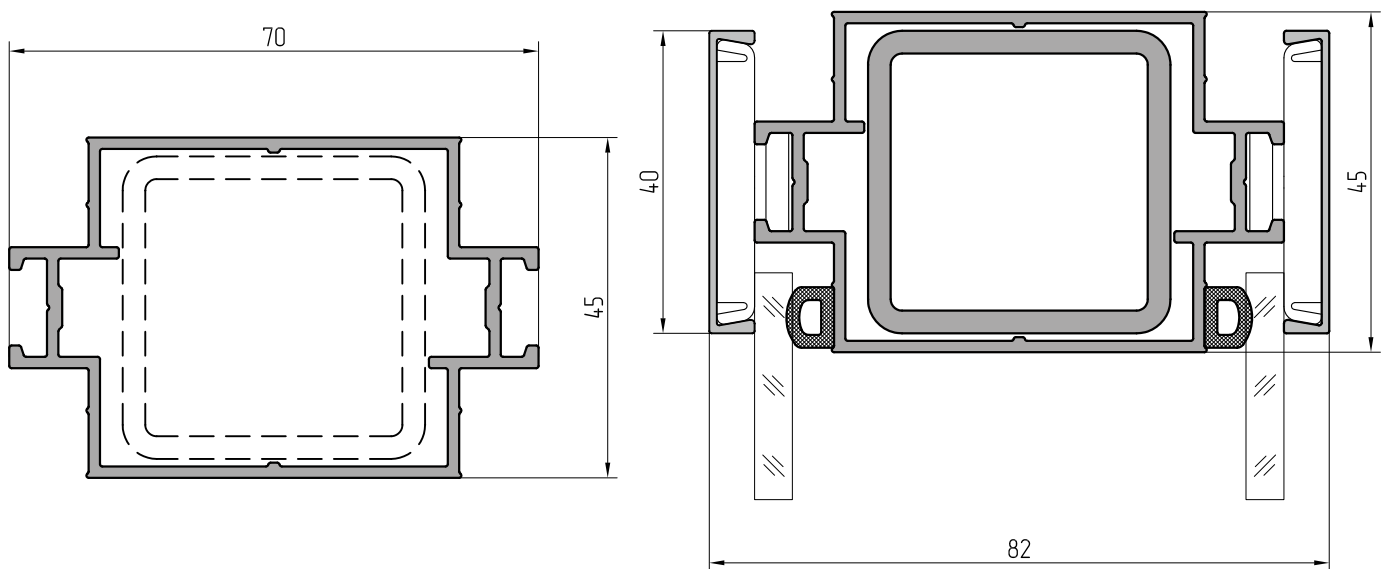
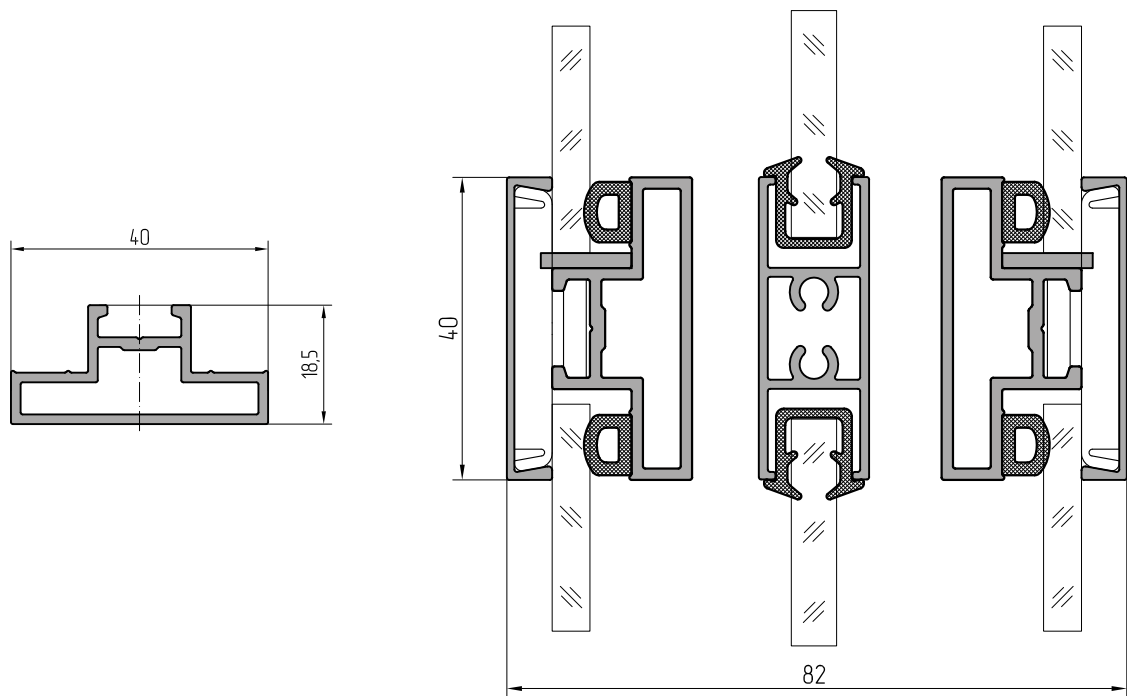
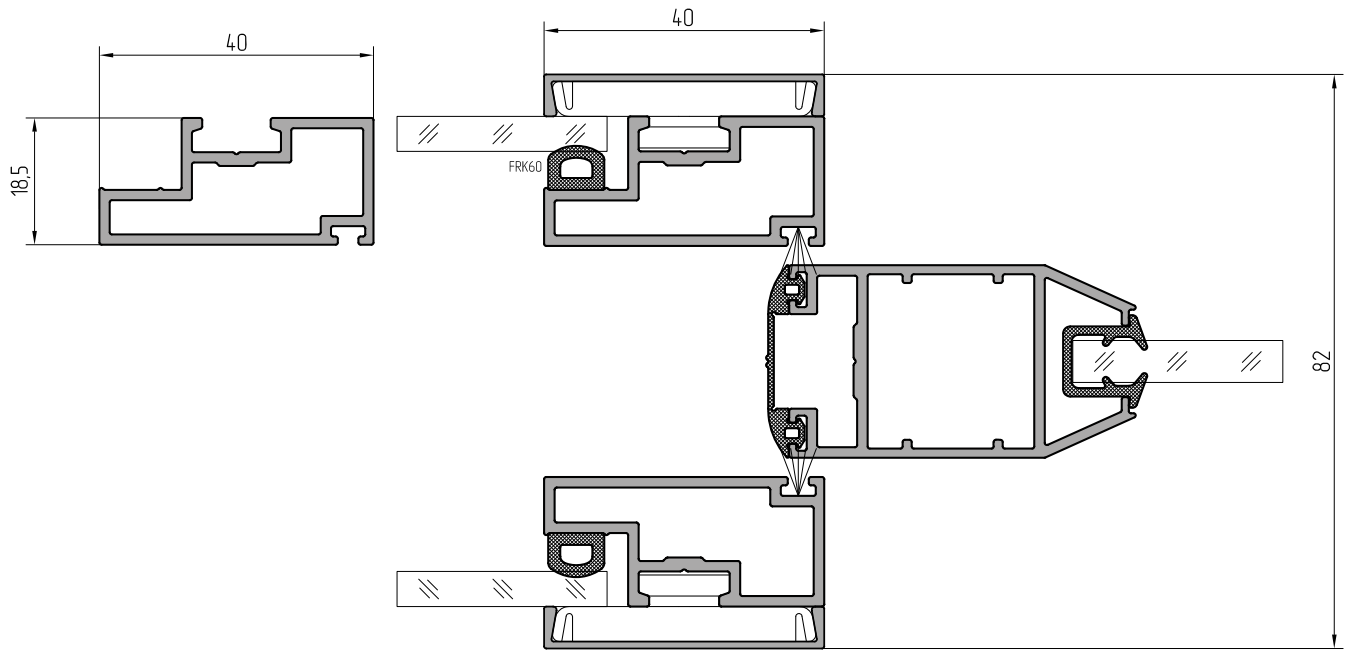

Fig.8

The second level transom Fig. 2 (6) gives an additional support to the guide rail transom. Initial profile for the second level transom is the same as for the reinforced profile. The quantity of the second level transom bars differs depending on the project.

Pos. 7 on Fig. 2 is the half-mullion (Fig. 9) serving as a frame of the door opening, Pos. 8 is the half-transom (Fig. 10) that is project specific.



## Door assembly

The door leaf profile on Fig. 11 (a) is cut at 45 angle on segments forming the contour of the door Fig.12 (1, 2). The contour of the door is assembled at the corners Fig.12 (6). The profile b on Fig.11, which is fixed by self-tapping screws Fig.12 (3, 10) is used as a transom.

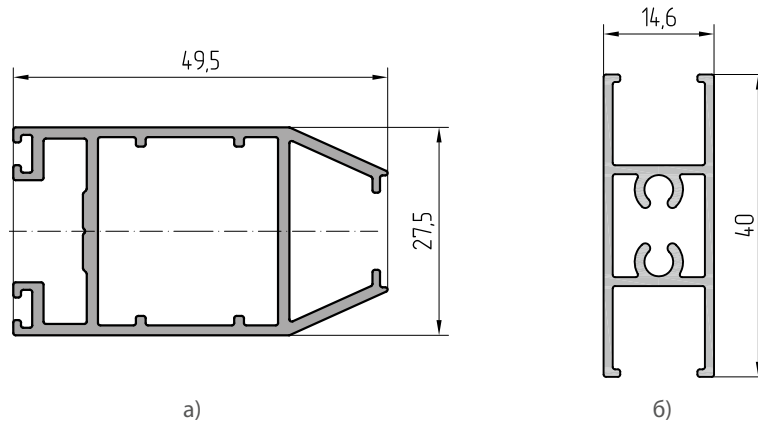

Fig.11

The brackets (7) are installed into the upper profile groove in advance. They are spaced apart from the edges of the profile and fixed with self-tapping screws. The felt seal (9) is also installed into the lower profile grooves in advance. The edges of the vertical profiles of the assembled door are covered by the seal (4). Finally, the rollers (8) are fixed with the use of threaded studs. The rollers can be adjusted relating to the surface of the upper profile and are guided to opposite directions of the door movement.

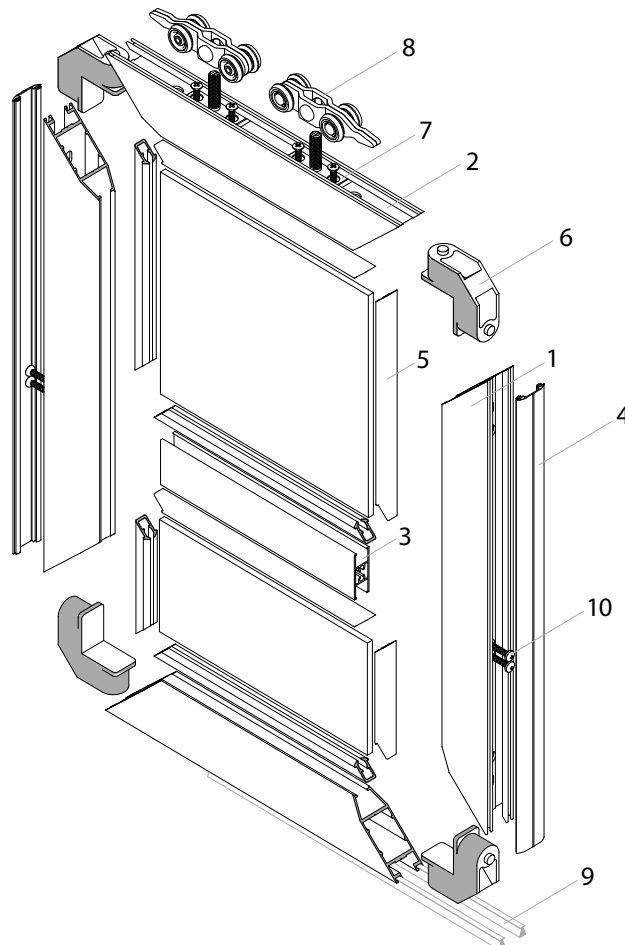

Fig.12

## Hardware

Rollers and door stops (Fig. 13).

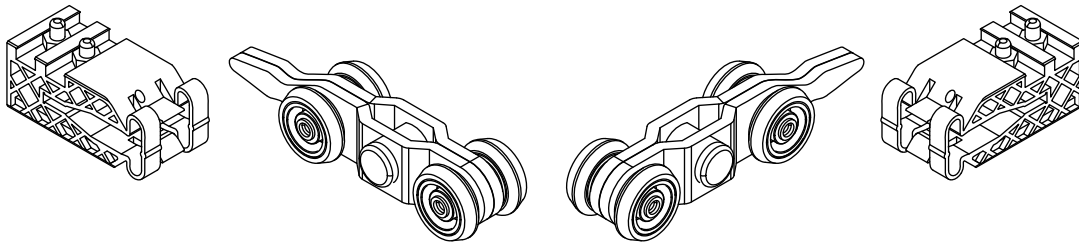

Fig.13

The brackets for the rollers installation to the door leaf (Fig. 14) are made taking into account the geometry of the groove and peculiarities of the rollers installation and adjustment.

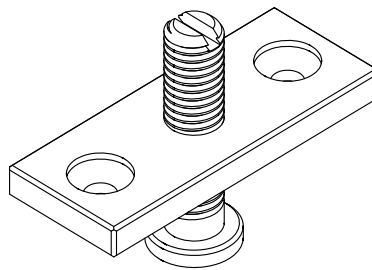

Fig.14

Special door hardware with ergonomic handles is used (Fig. 15).

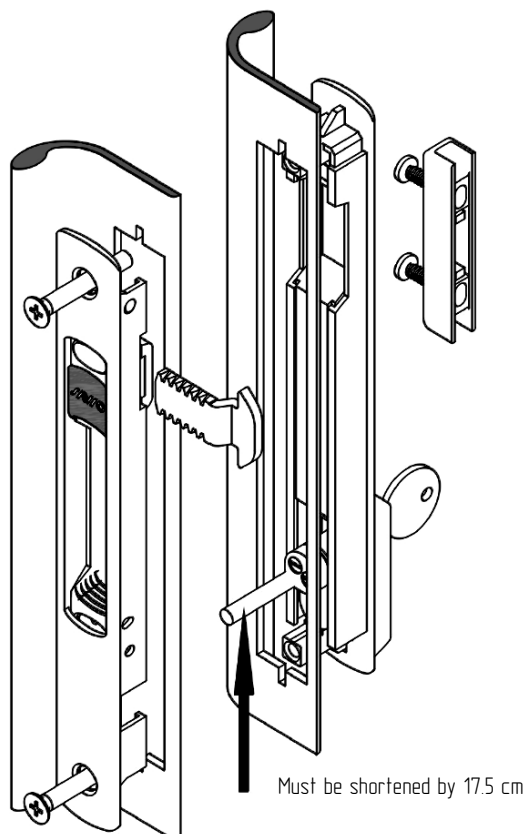
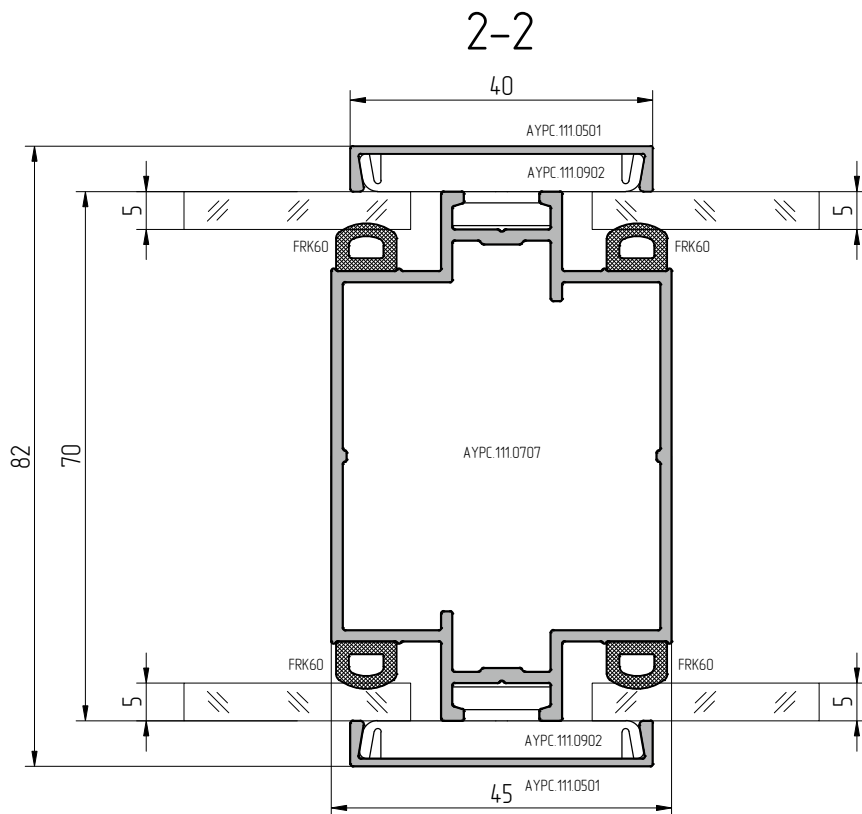
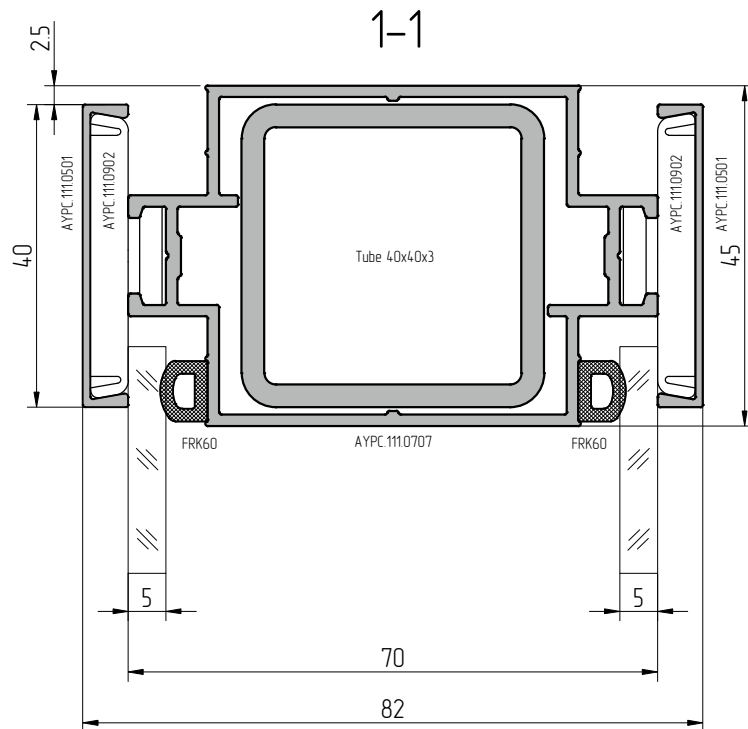
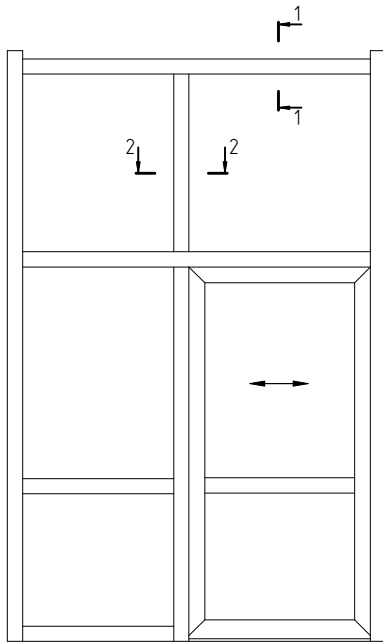
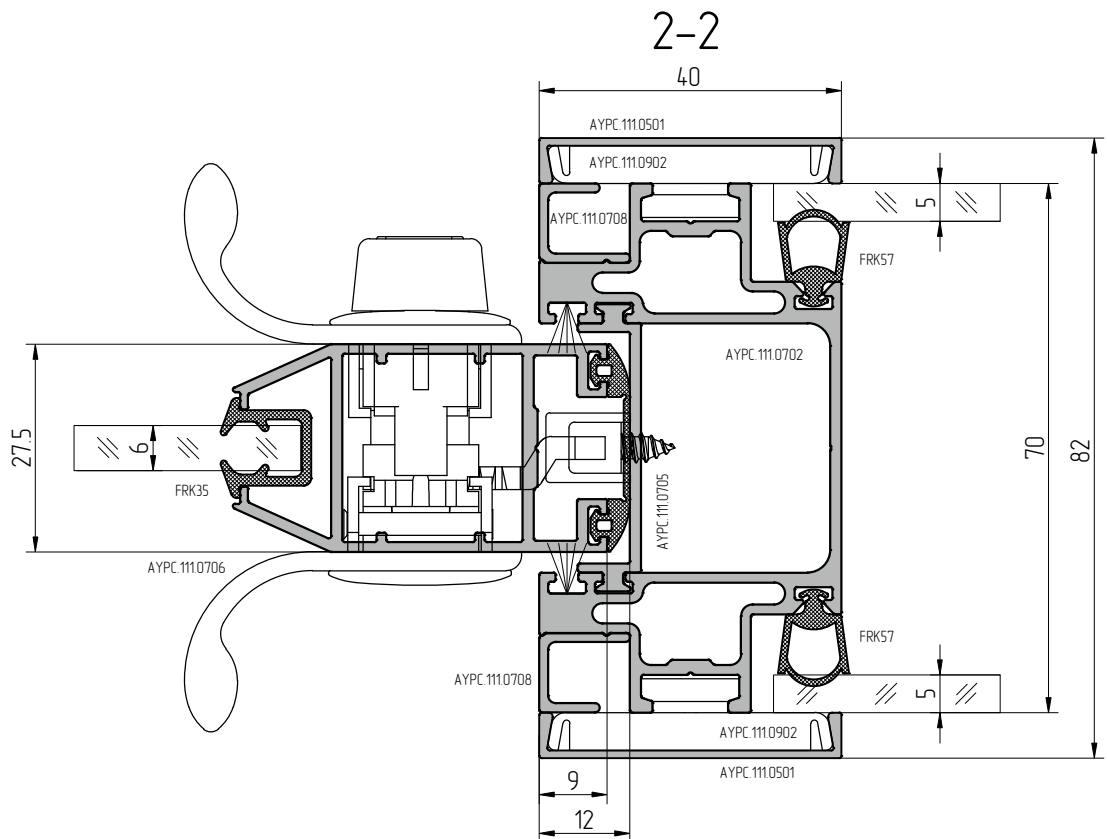
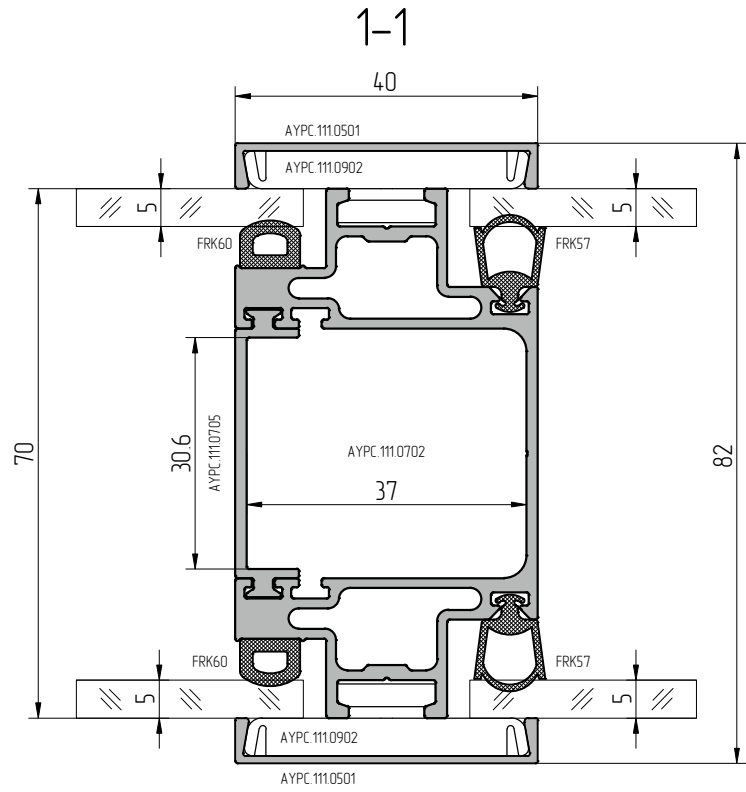
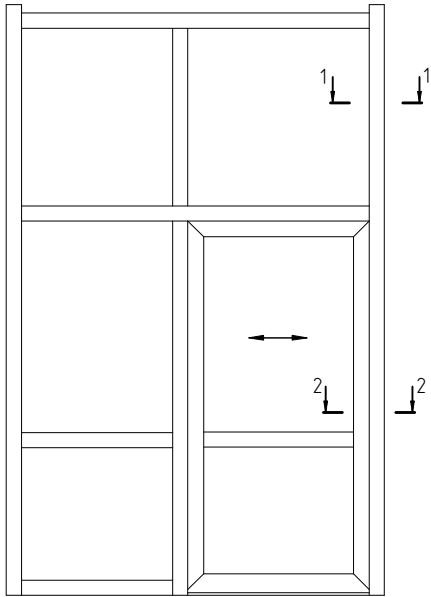
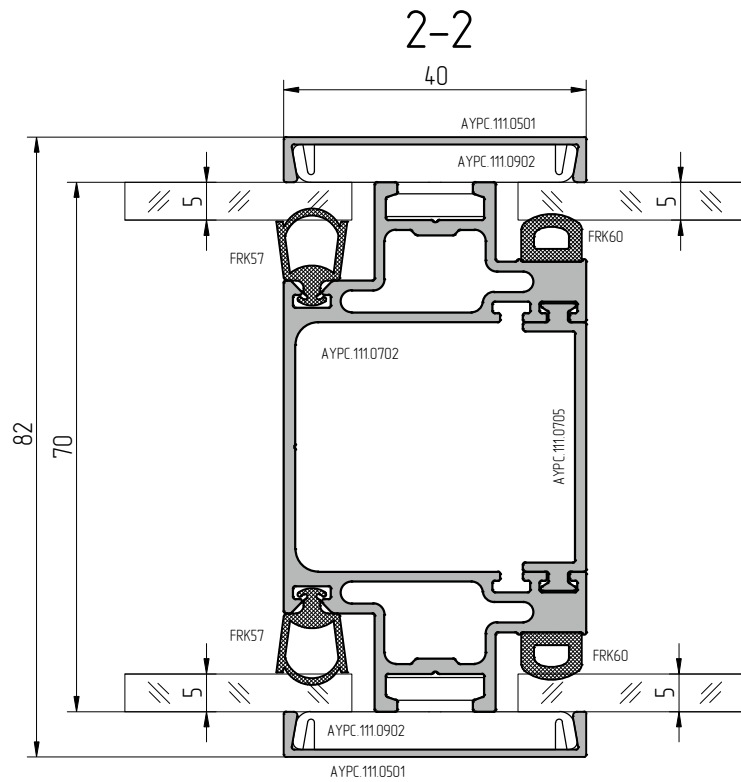
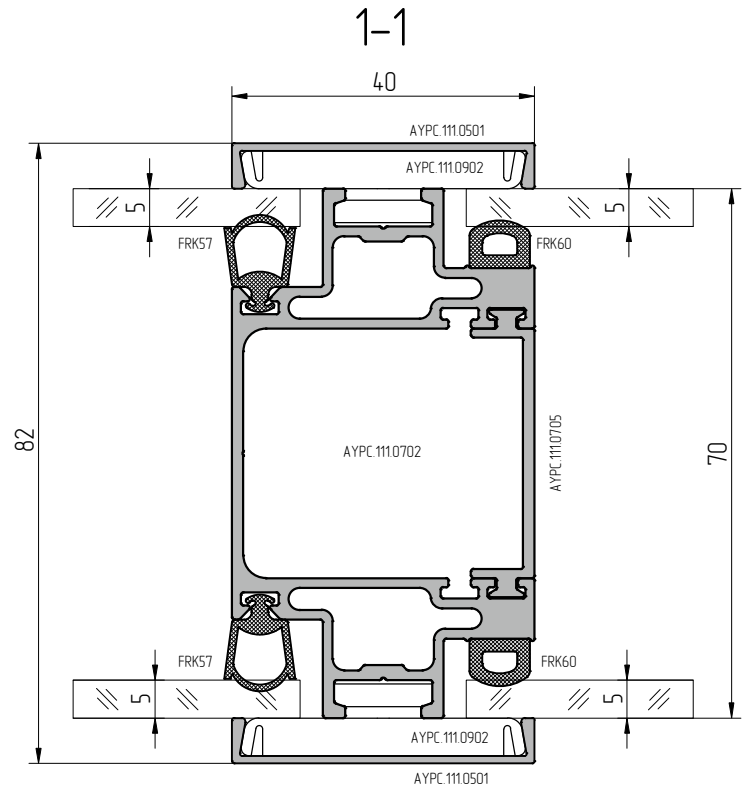
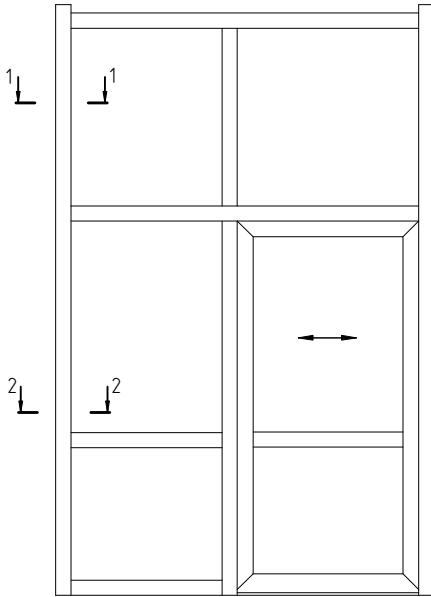
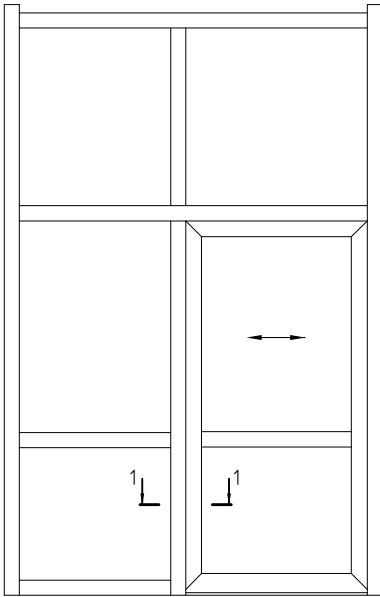

Fig.15









1-1

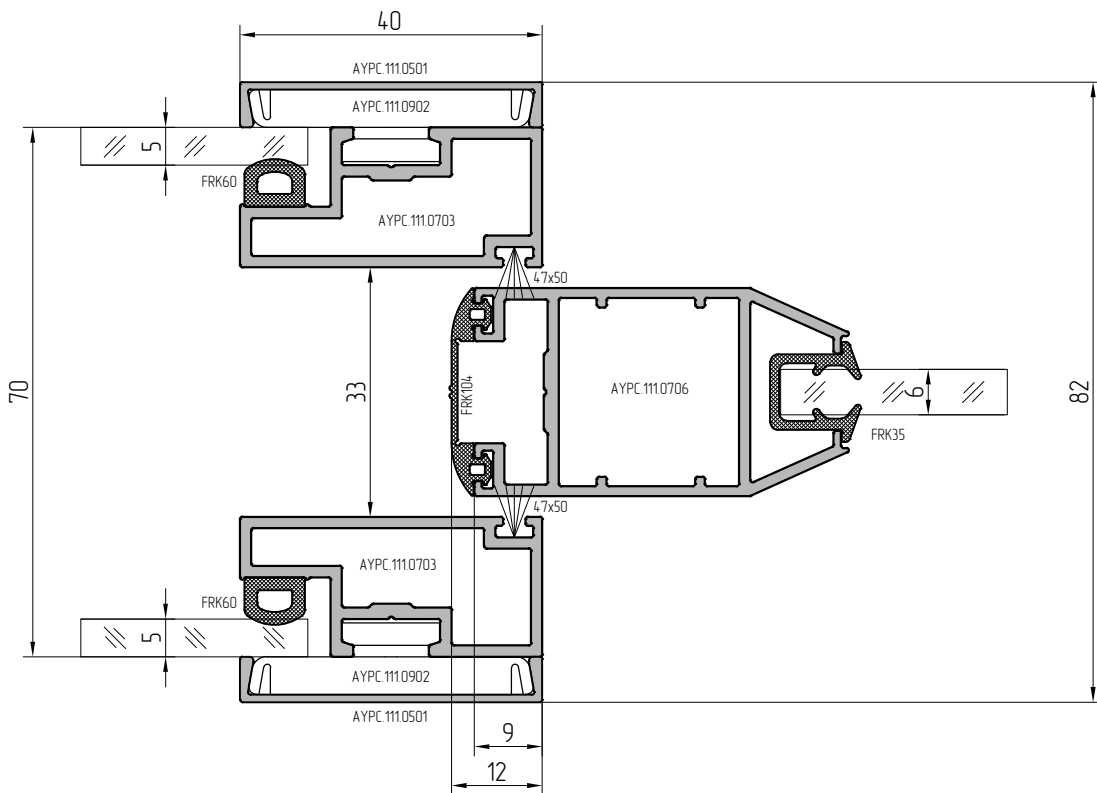





Option with opened door

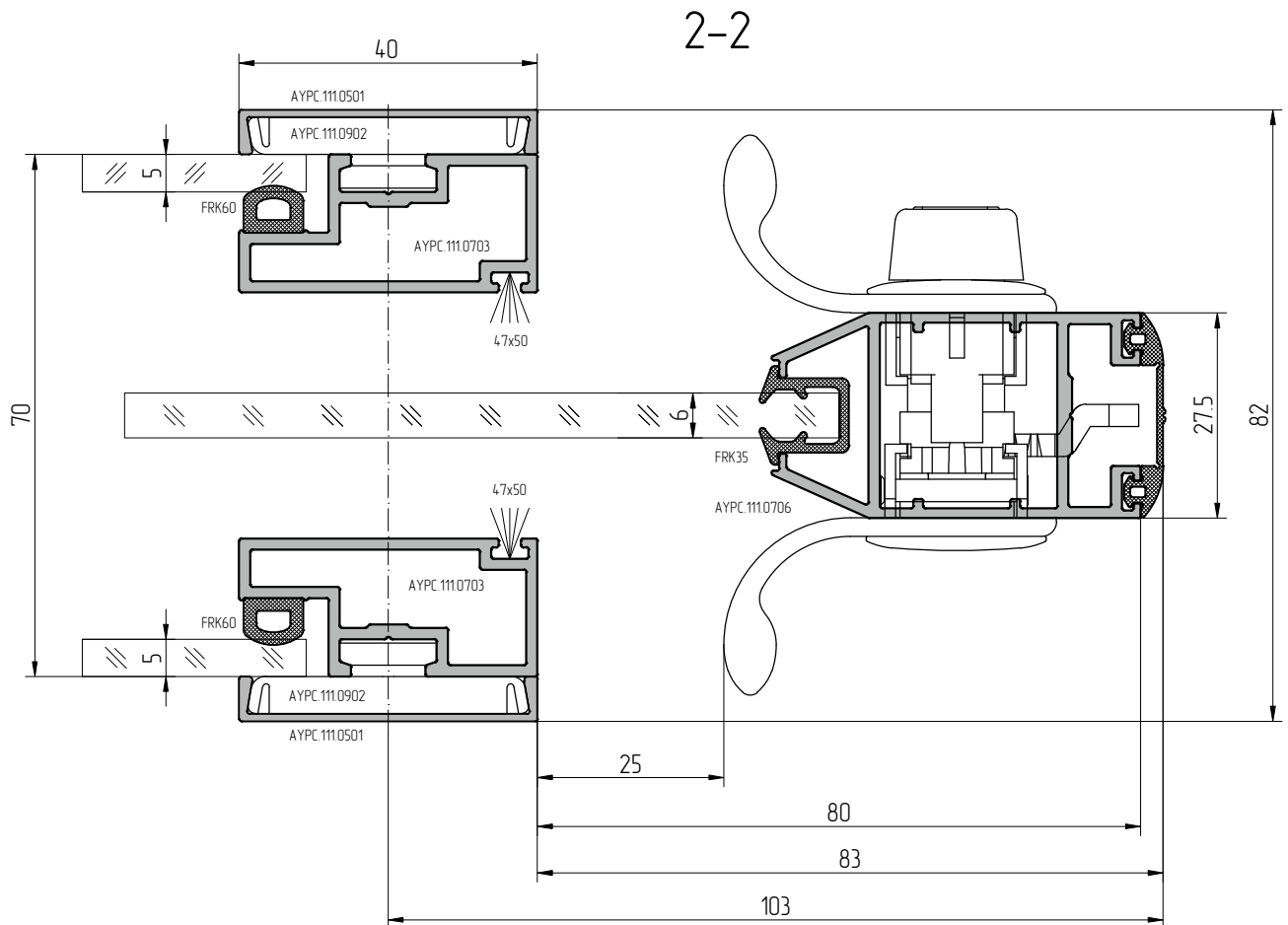
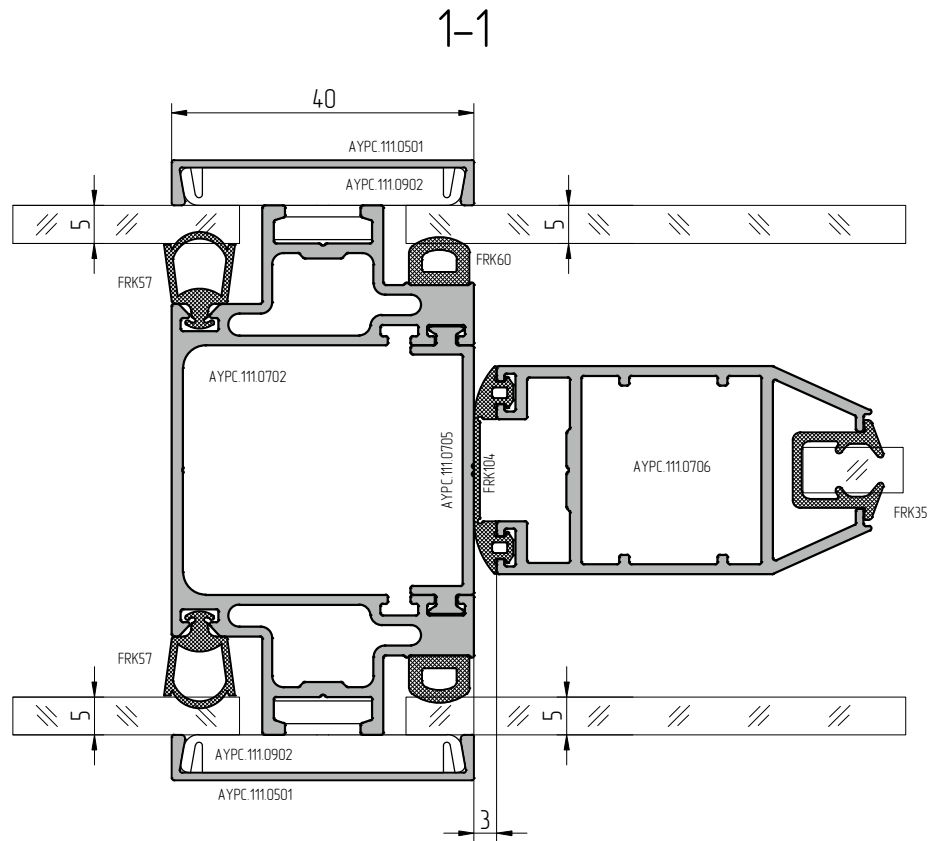
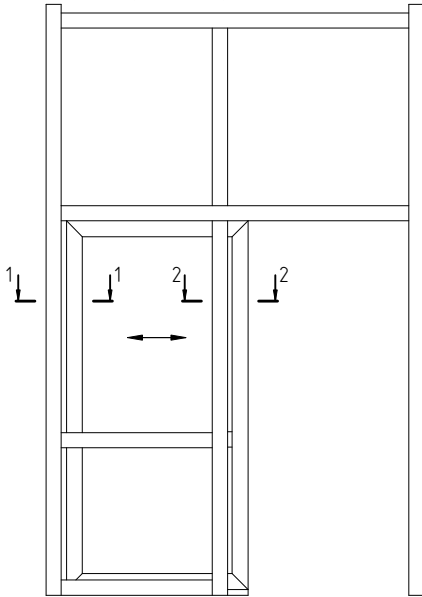

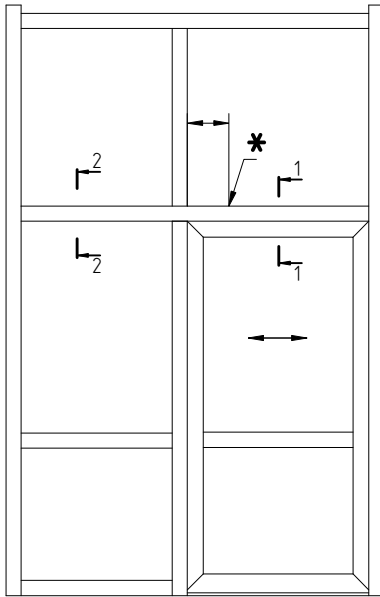

\* The best location of  $\varnothing 12$  mm hole should be defined depending on its purpose.  
For the example shown, the hole should be spaced 100 mm from the mullion edge which allows to drive both rollers to the adjustment hole.

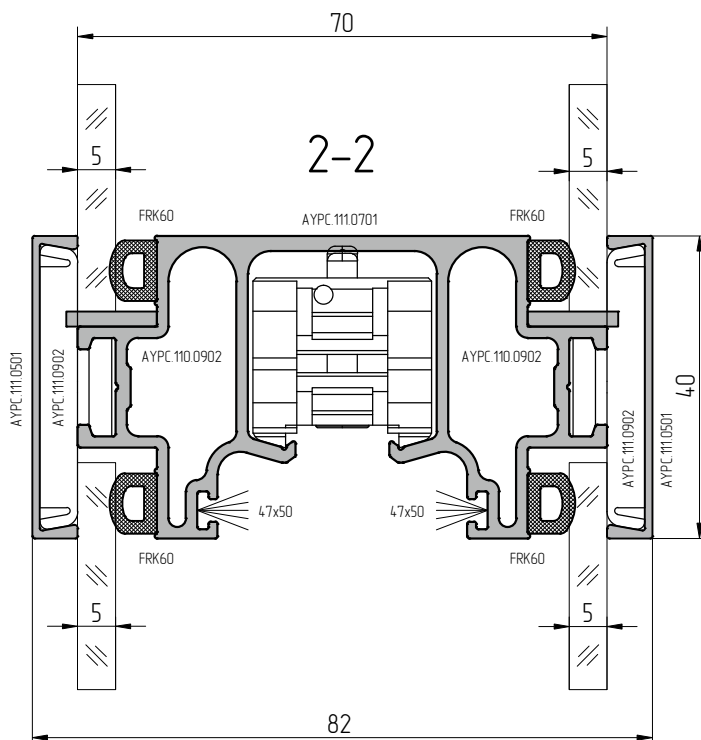
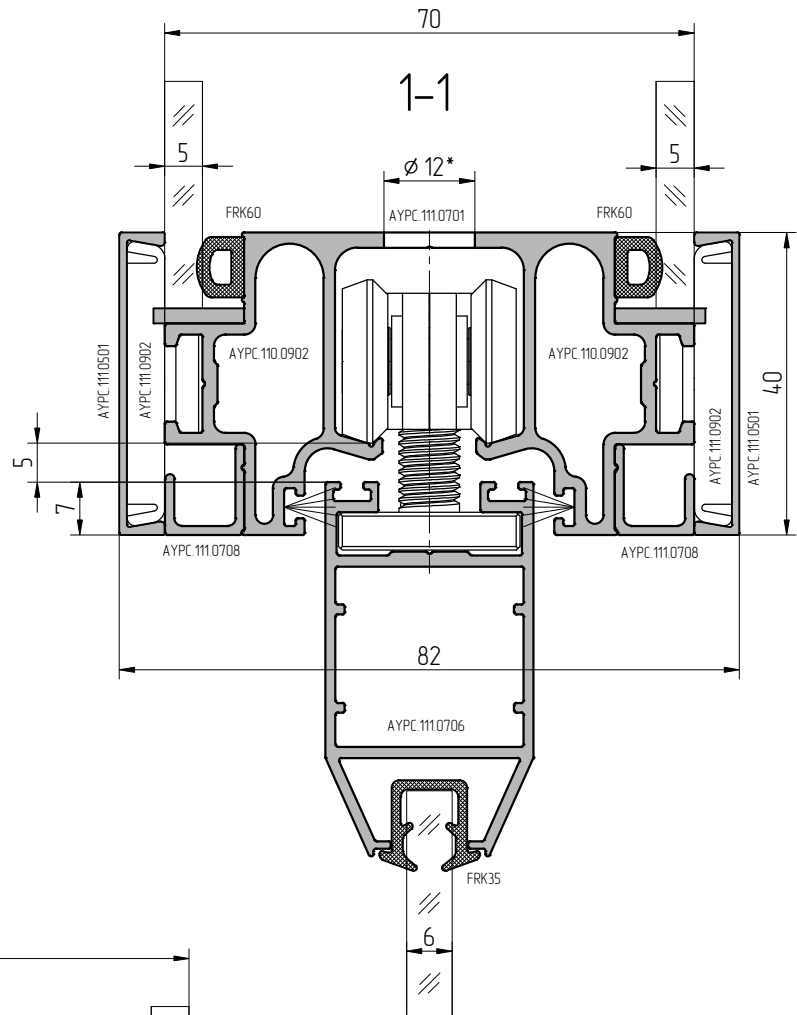

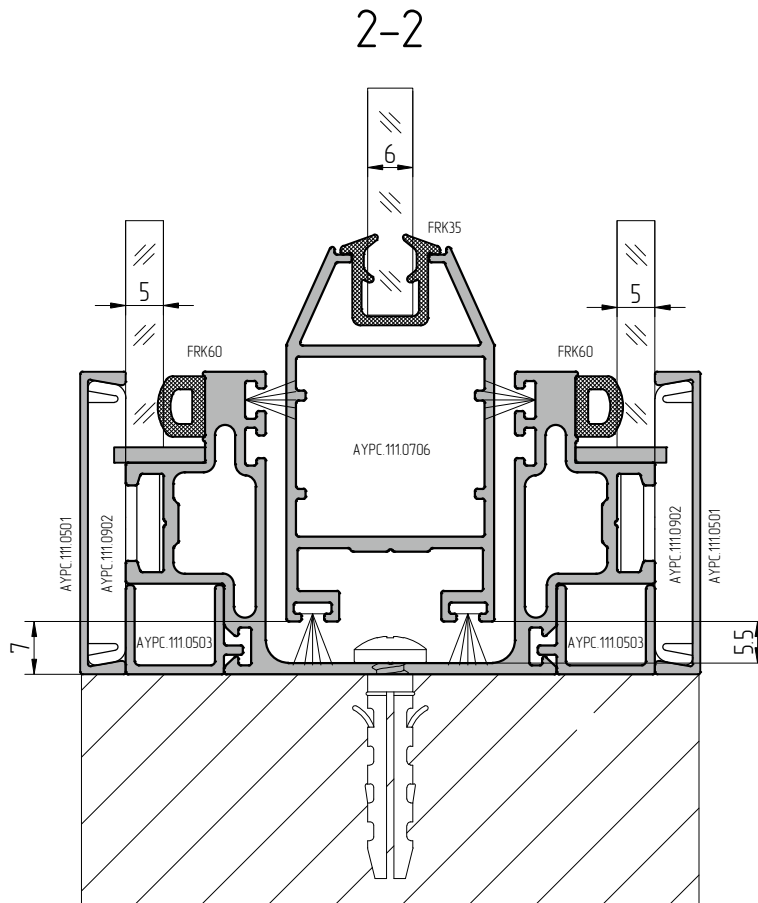
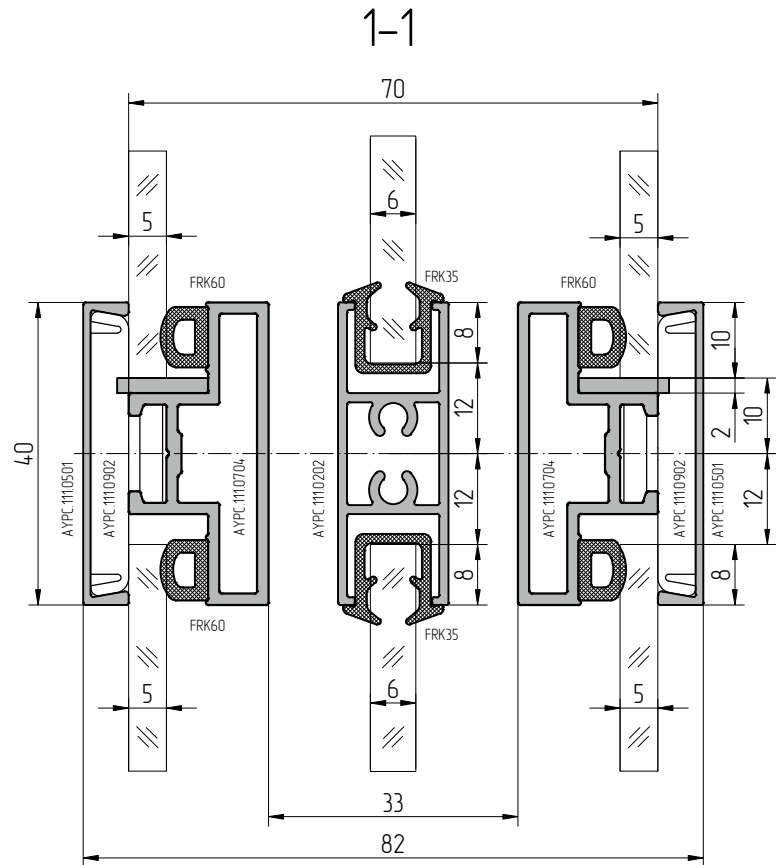
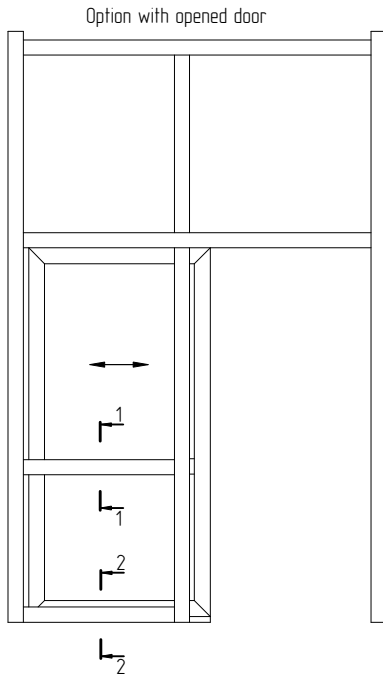

Only modified AYPC.111.0951M and AYPC.111.0952M brackets should be used for sliding door framework assembly.

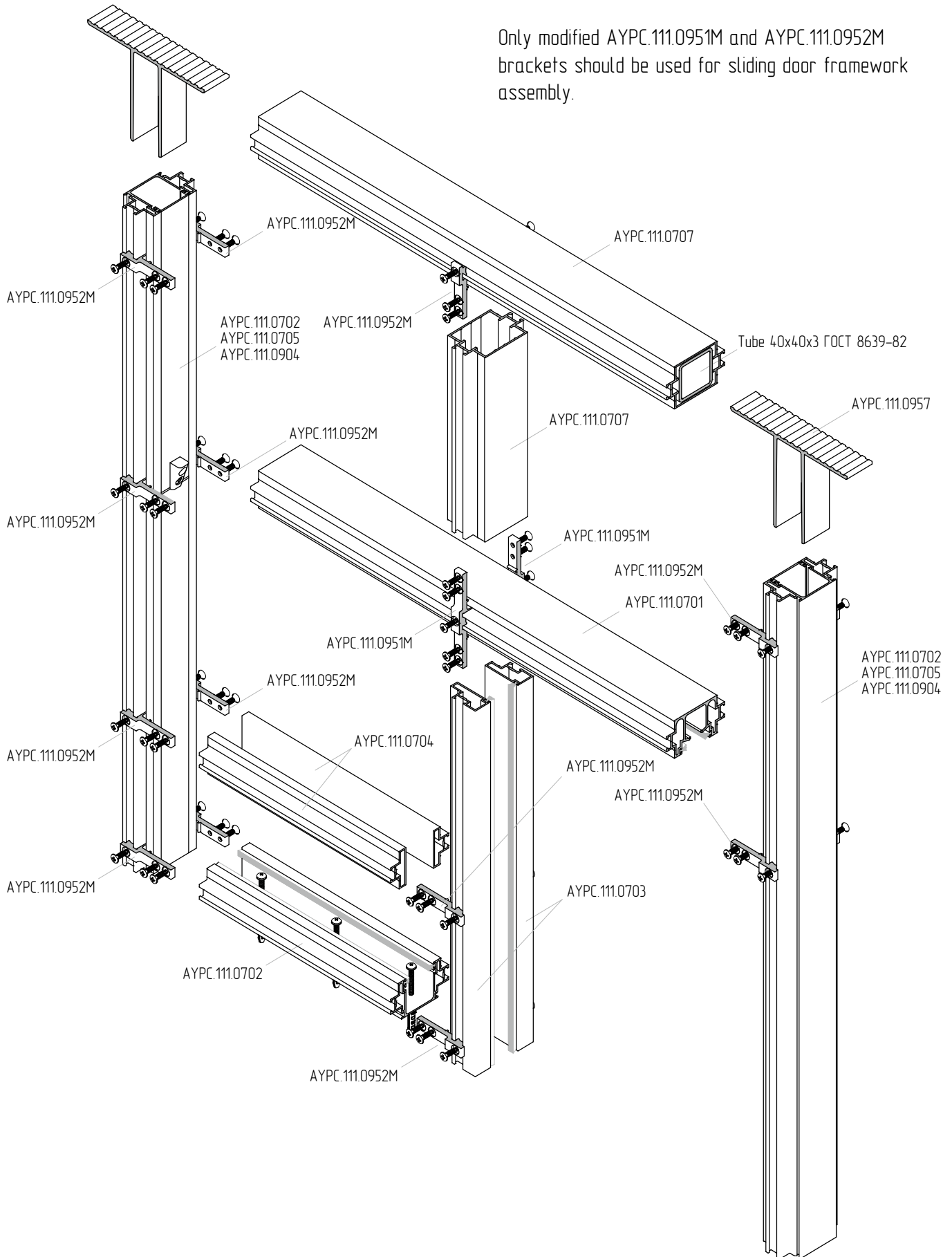

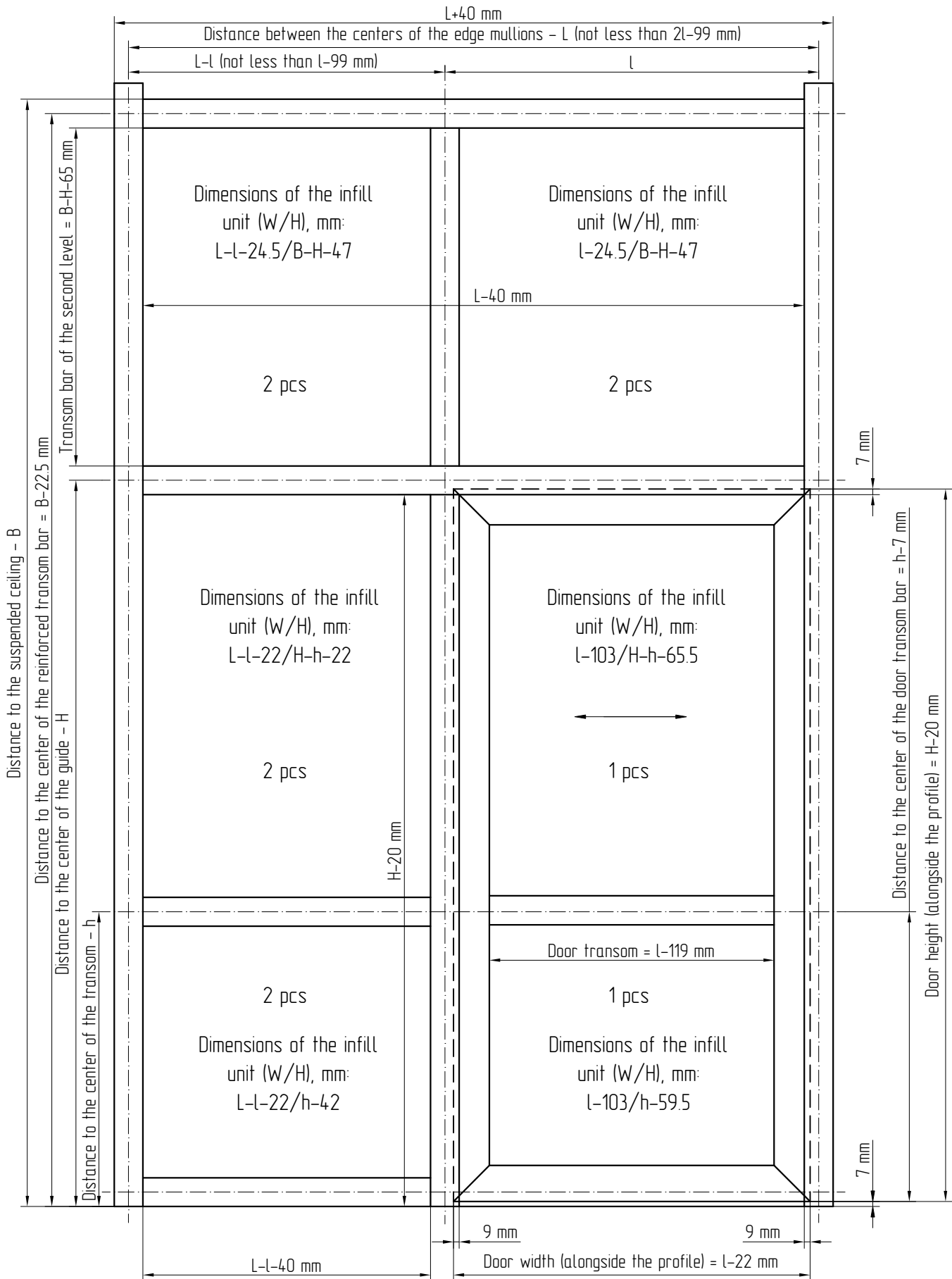

Dimensions of the door opening (Height/Width) =  $H-20$  mm/ $L-123$  mm

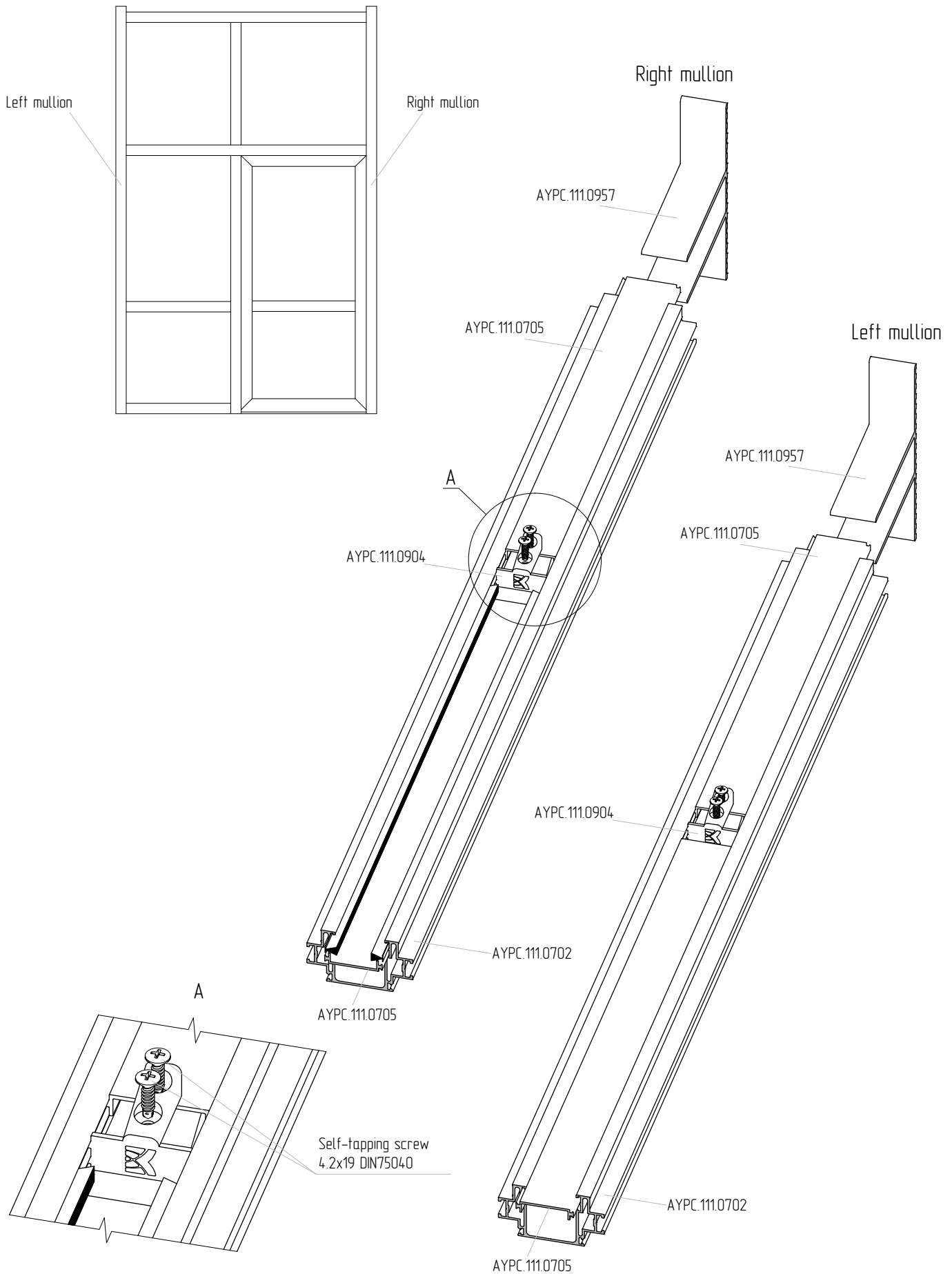

The image shows the dimensioning of the AYPC.111.0705 auxiliary profile segments as a part of mullions. If there is a floor slope between mullions, it must be measured and taken into account when dimensioning the AYPC.111.0705 bottom profile segments, as it ensures the horizontal position of the guide.

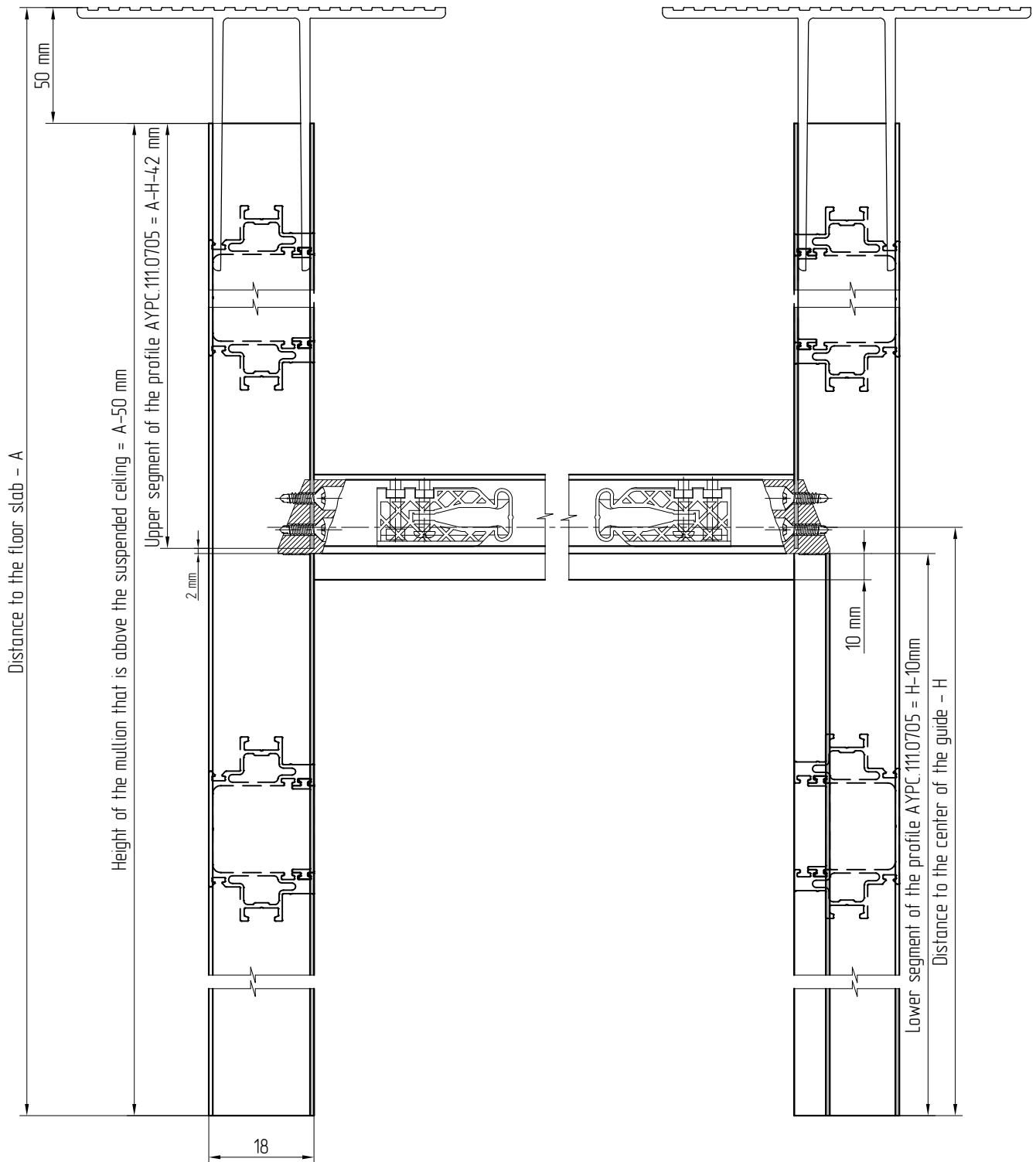



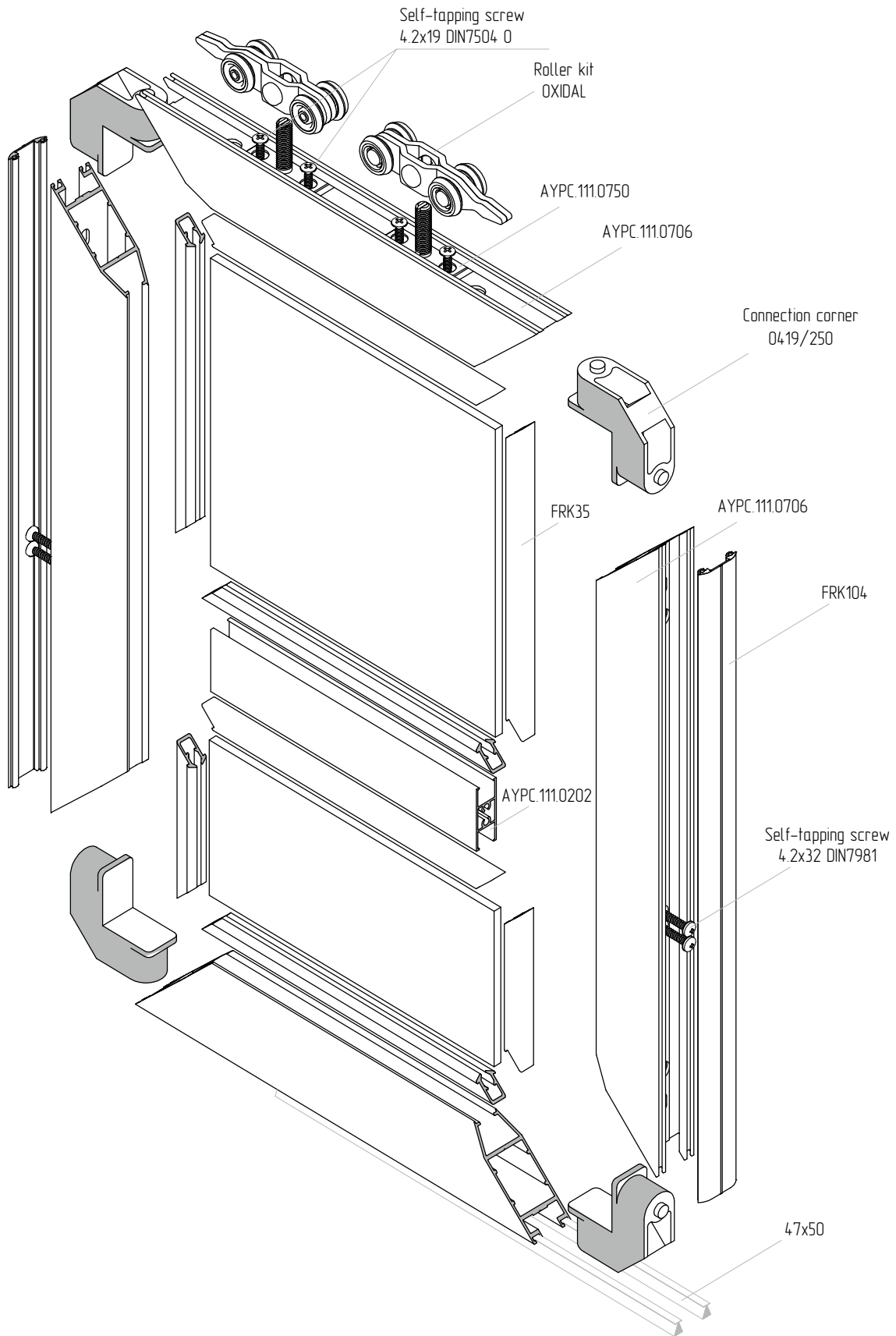

The distance between the roller bearing surface and the upper end of the horizontal door leaf profile must be 5 mm. For proper roller positioning, as an alternative, it is recommended to use leveling support 5 mm thick.

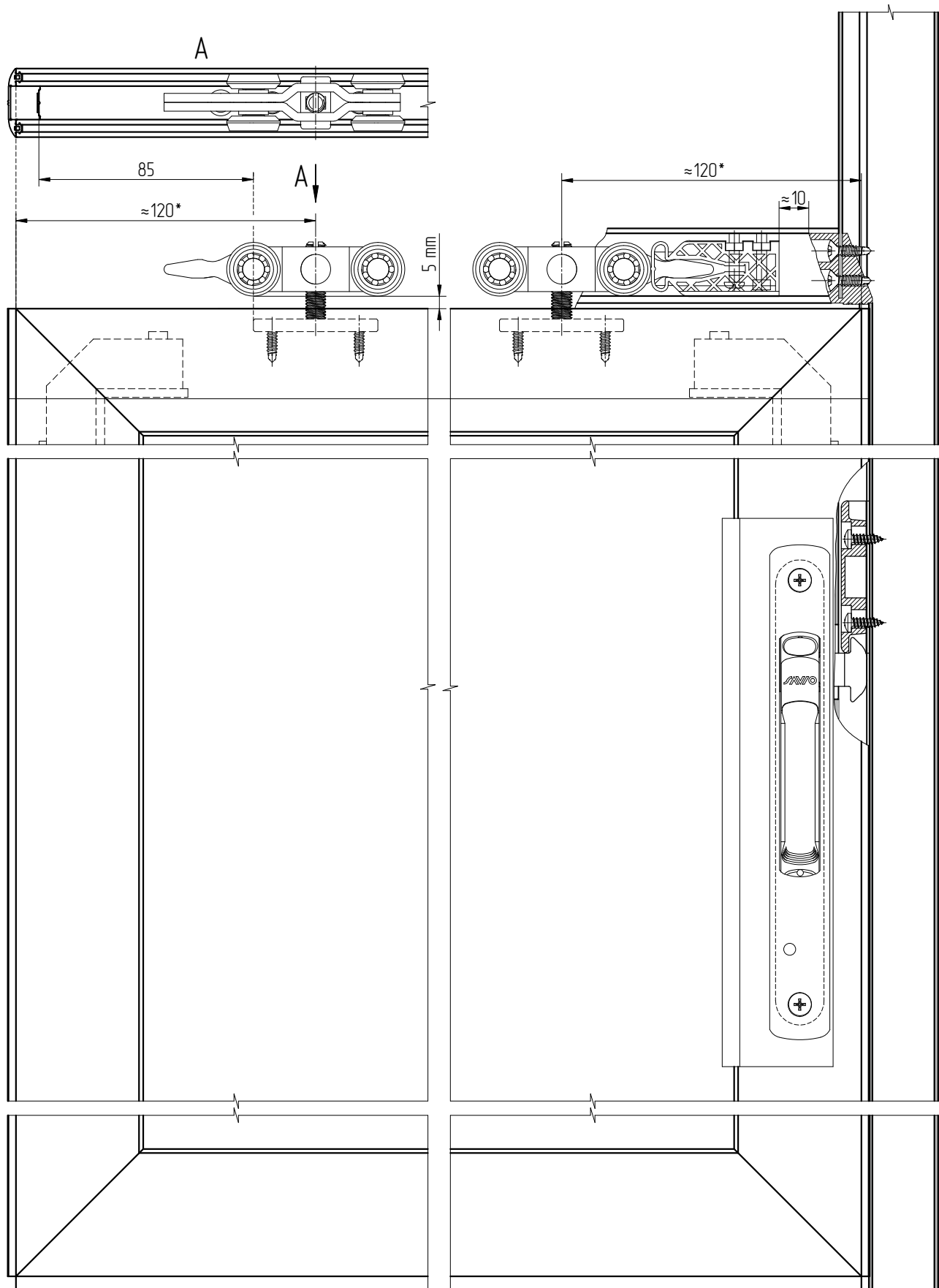

1

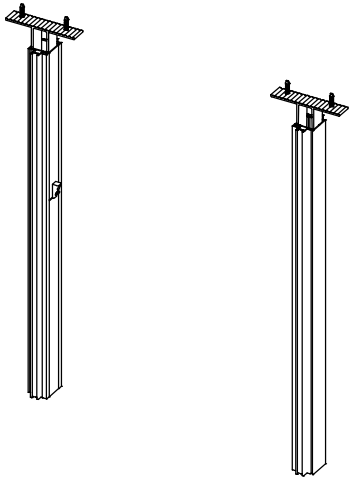

2

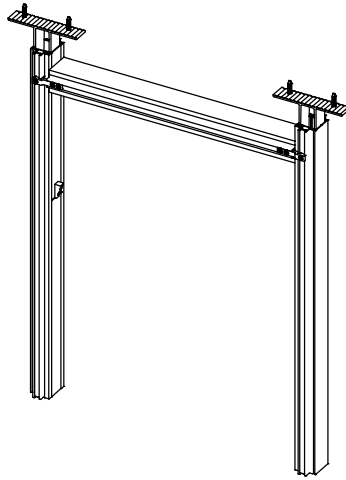

3

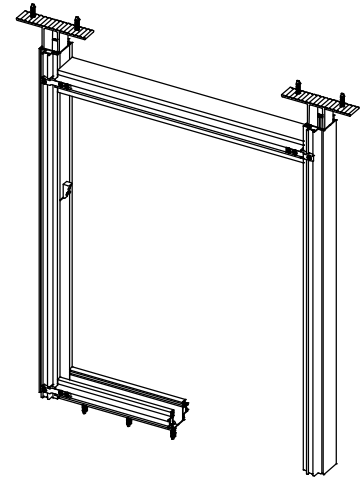

4

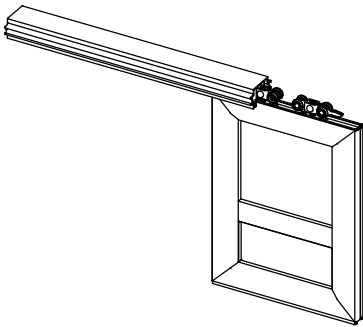

The stops are installed into the guide simultaneously

5

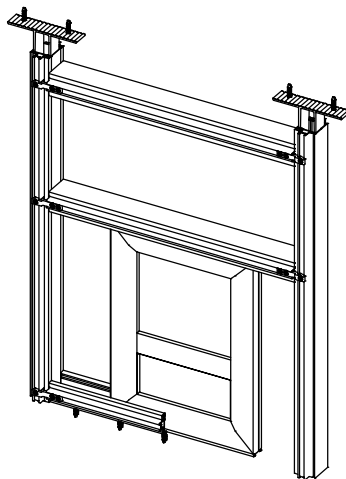

6

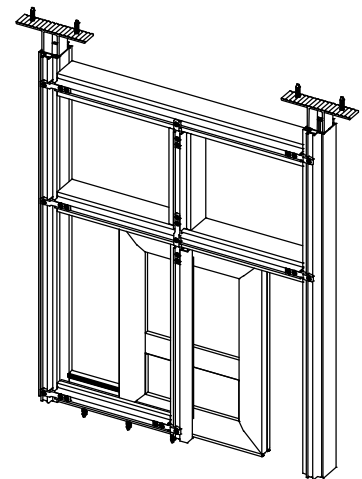

7

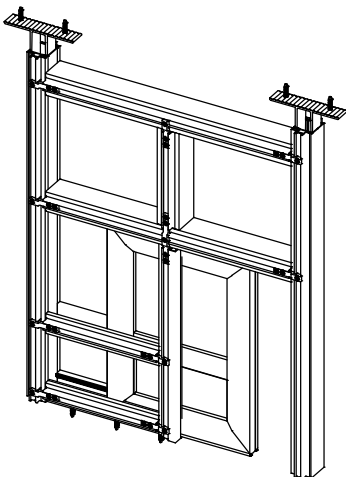

8

Then the infill unit is installed in fixed zone, fixed with AYPC.111.0901 and AYPC.111.0902 clamps, which are covered by the decorative caps

Profile corner connection

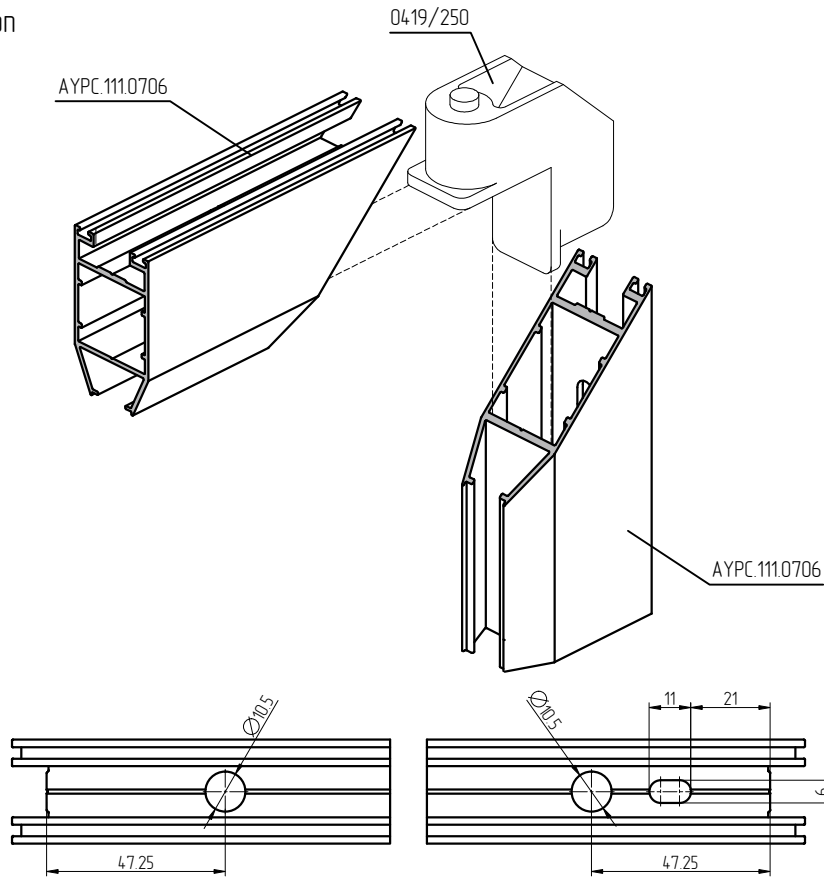

Profile processing for hardware installation

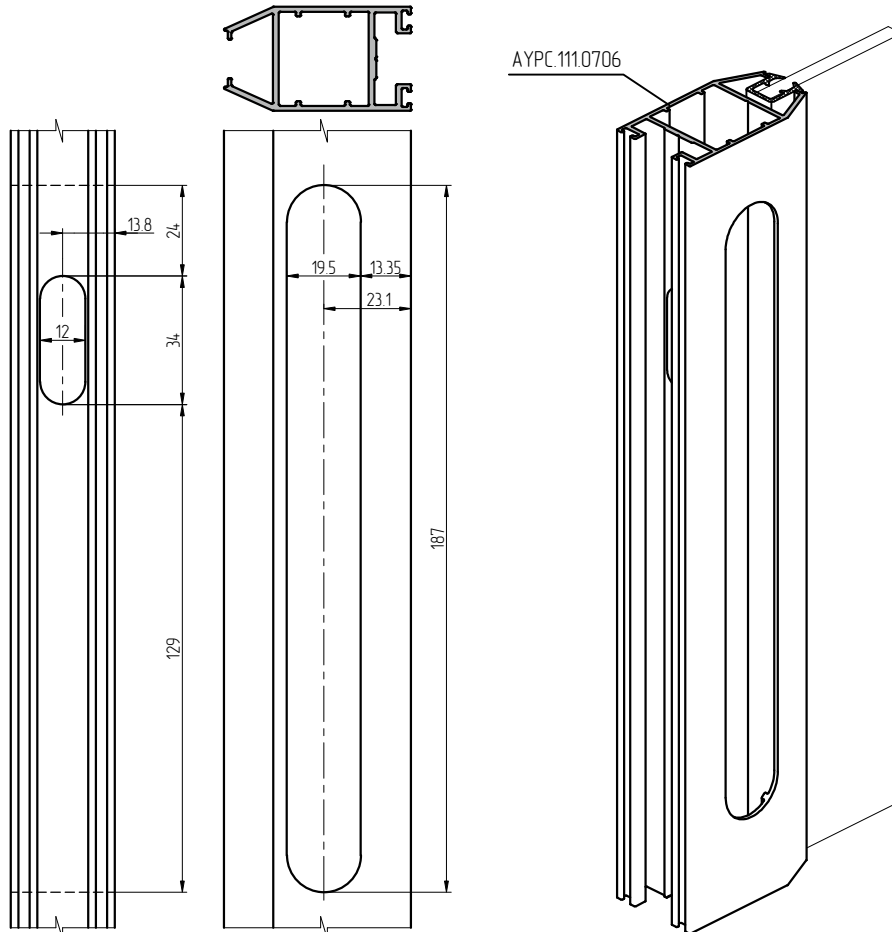

Gasket processing

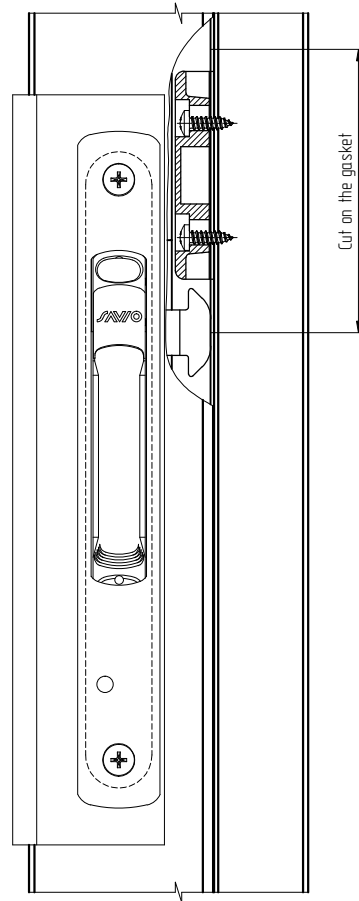
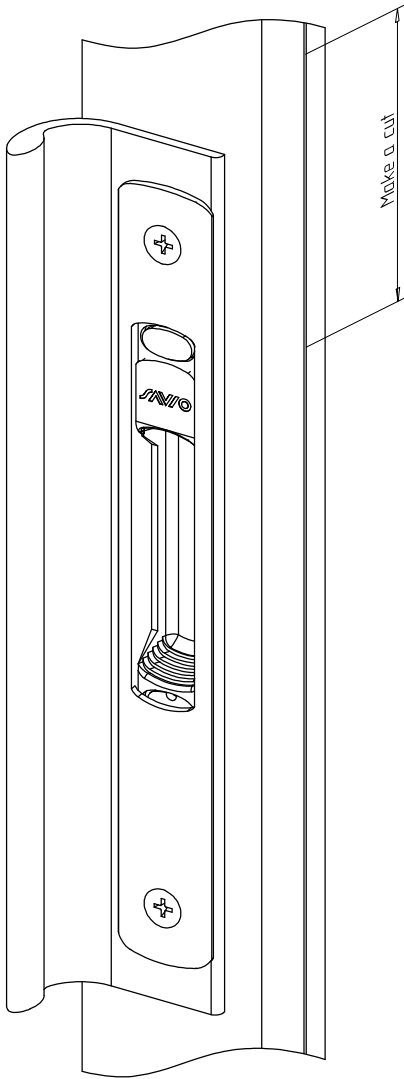

Perform a cut in the center of the gasket (the cut should be 10-15 mm longer than the strike plate) as shown on the figure.

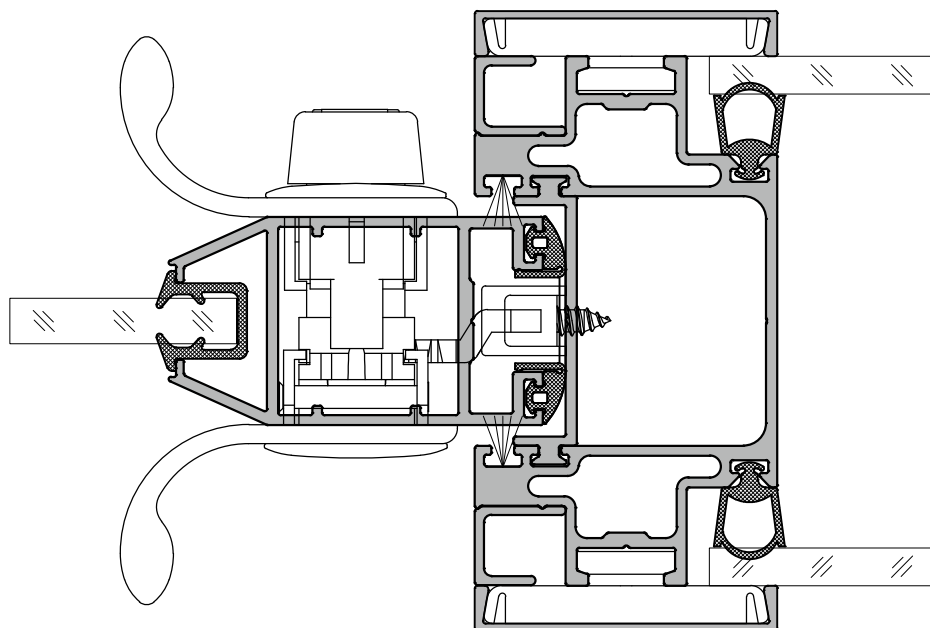

Before the infill unit installation it is necessary to make the final roller adjustment through the hole with a diameter of 12 mm in the upper wall of the AYPC.111.0701 transom guide. The hole should be placed in such a way that both rollers can be adjusted.

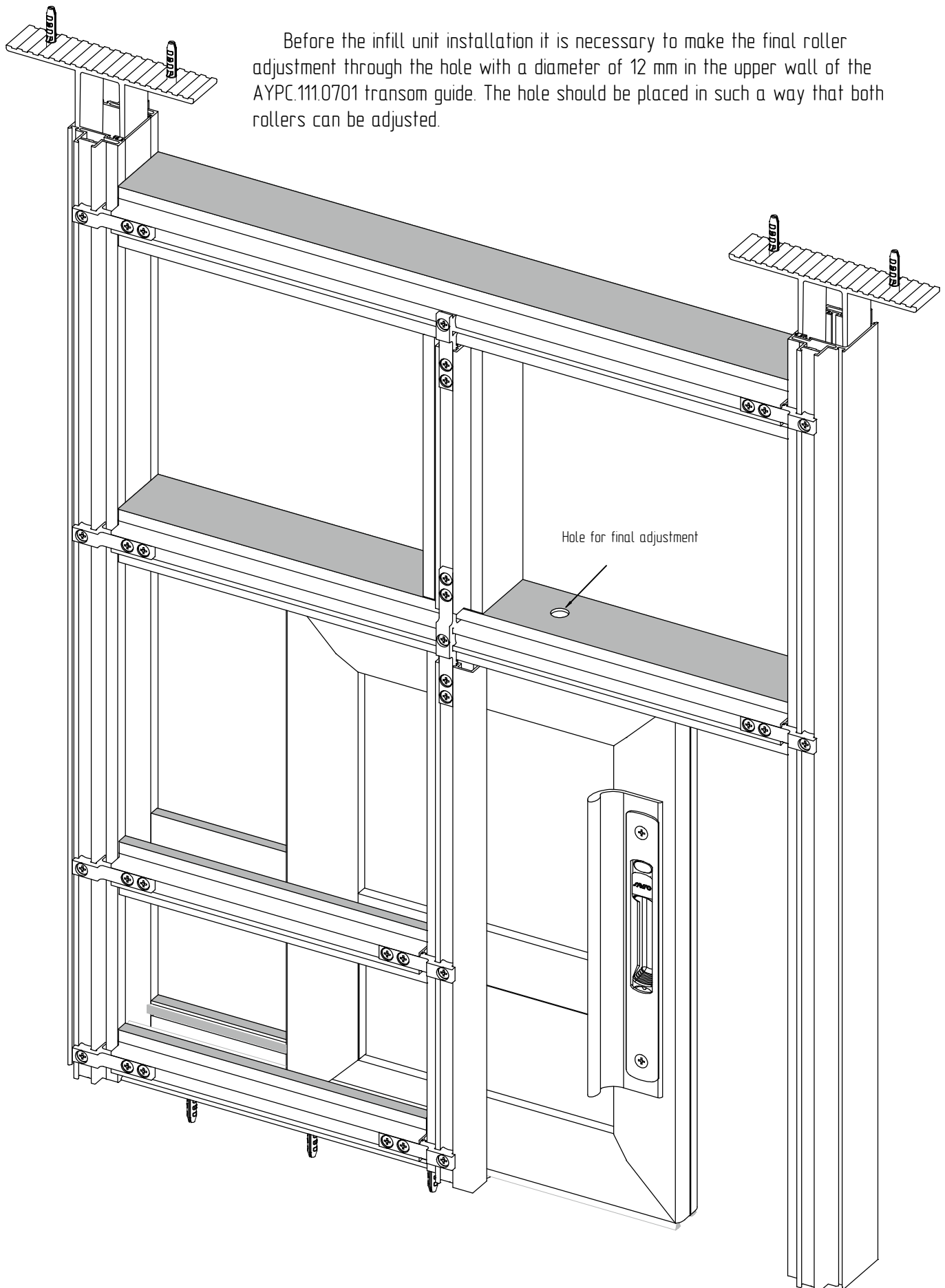

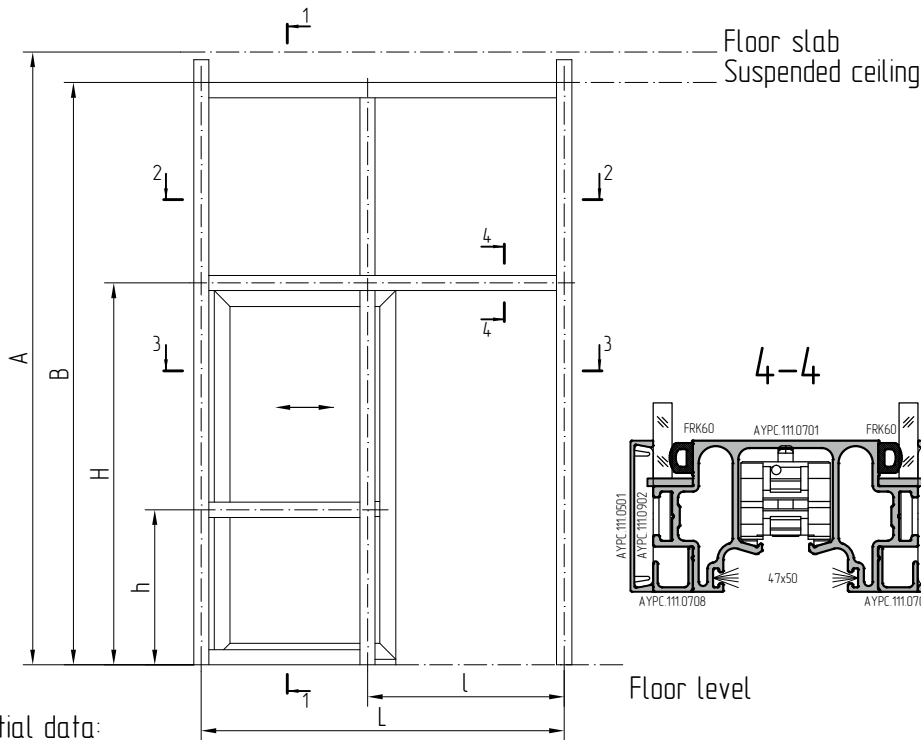

Initial data:

- distance between floor and floor slab - A mm;
- distance between floor and suspended ceiling - B mm;
- distance between floor and guide center - H mm;
- distance between floor and transom center - h mm;
- distance between central axes of the edge mullions - L mm;
- distance between central axes of the doormullions - l mm.

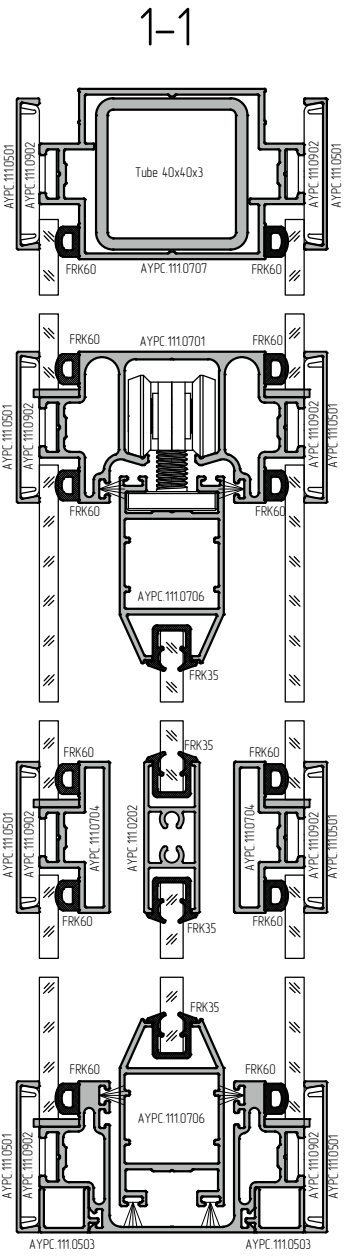

2-2

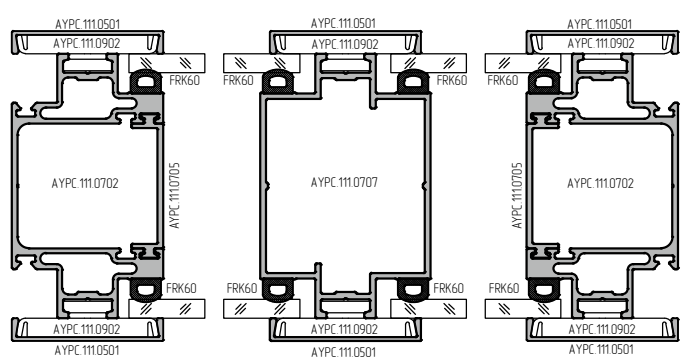

3-3

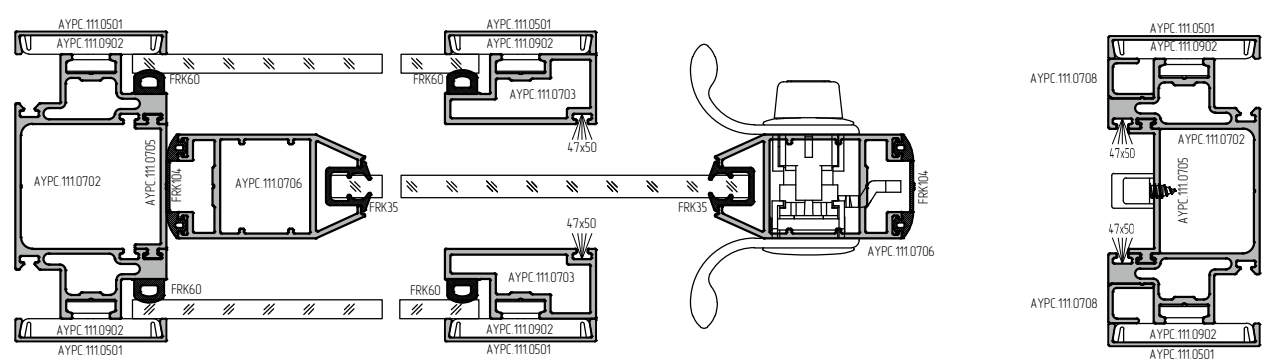











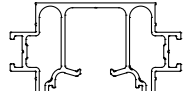

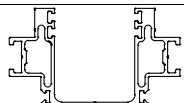
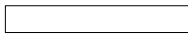







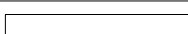









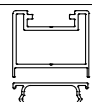

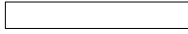

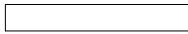

Article	Image	Size, mm	Qty, pcs	
AYPC.111.0701			L-40	1
AYPC.111.0702			A-50	2
			L-L-40	1
AYPC.111.0703			H-20	2
AYPC.111.0704			L-L-40	2
AYPC.111.0705			A-H-42	2
			H-10	2
AYPC.111.0706			L-22	2
			H-20	2
AYPC.111.0707			B-H-65	1
			L-40	1
AYPC.111.0708			H-8	2
			L-33	2
AYPC.111.0709			B	2
AYPC.111.0605			B	2
AYPC.111.0202			L-119	1
AYPC.111.0501			A-50	4
			B-H-65	2
			H-20	2
			L-40	4
AYPC.111.0503			L-L-40	2
Tube 40x40x3 GOST 8639-82			L-40	1
Gaskets and accessories				
FRK35		Rubber gasket	2H+4L-634	
FRK60		Rubber gasket	14L-6L+2A+6B-4H-1090	
FRK104		Rubber gasket	H-20	2
47x50		Felt seal	4H+4L-288	
AYPC.111.0750		Bracket		2
AYPC.111.0902		Clamp	(2A+B+4L-2L-345)/150	
AYPC.111.0904		Plug		2
AYPC.111.0951M		Bracket		2
AYPC.111.0952M		Bracket		18
AYPC.111.0957		Joining element		2
0419/250		Corner connector		4
R460		Roller kit		1
111SL06 (111SL16, 111SLE6)		Handle kit		1
4.2x19 mm		Self-tapping screw 4.2x19 DIN7504 0		72
4.2x32 mm		Self-tapping screw 4.2x32 DIN7981		4

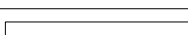
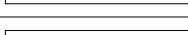

Chart for determining the maximum allowable weight of the door leaf depending on the dimensions and door design

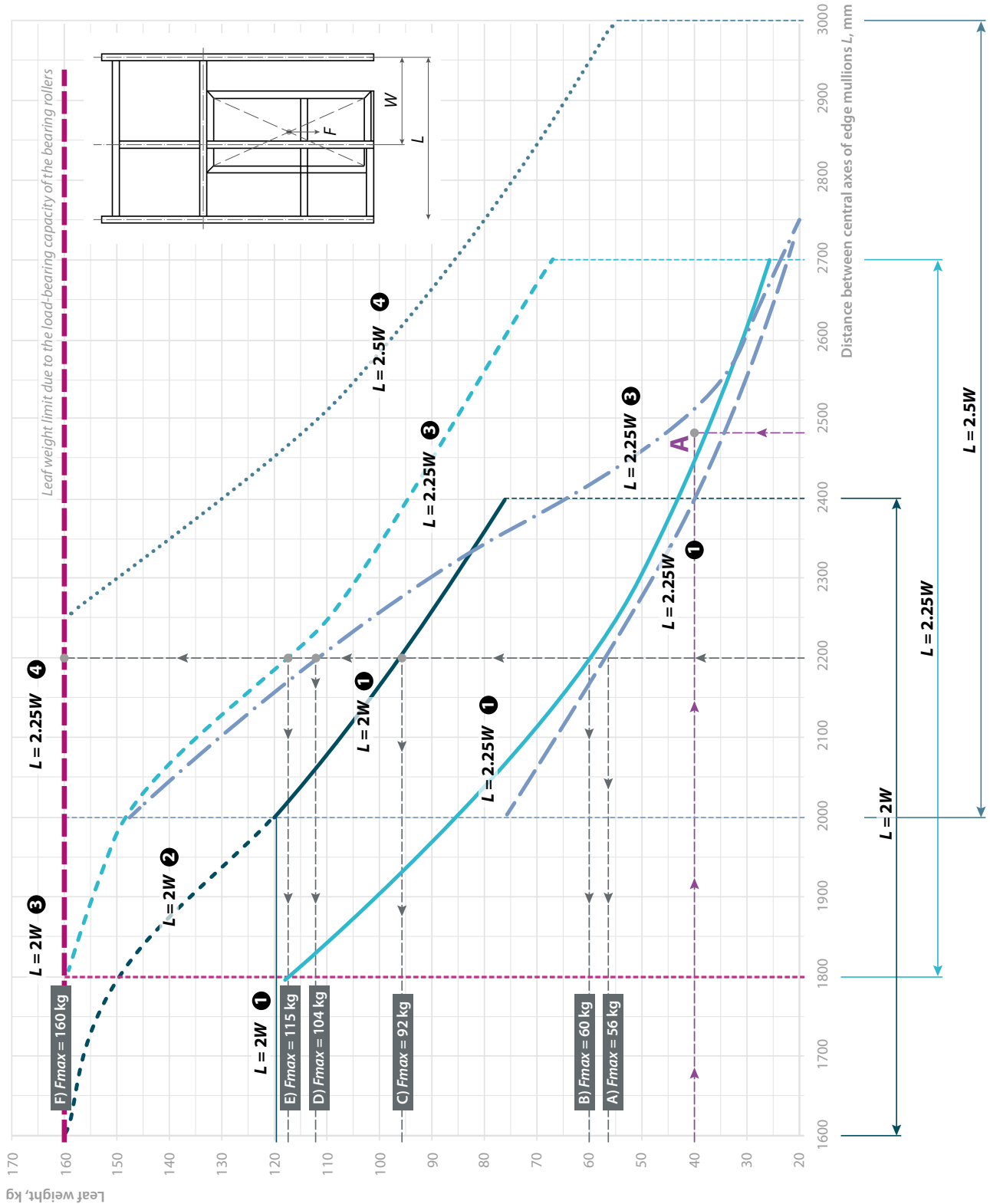

## Instructions on the practical use

### Initial data

- $L$  (x-axis on the diagram, mm) is a project distance between the central axes of the edge mullions.
- The required door opening width is defined as the distance between the central axes of the door opening mullions minus the visible mullion width ( $W - 40$  mm,  $W_{calc.} = 800 - 1200$  mm).

On the diagram each line is lettered in accordance with the  $L/W$  ratio.  $L = 2W$  (symmetrical design),  $L = 2.25W$  and  $L = 2.5W$ . In practice, the  $L/W$  ratio will be at any value within the range of [1.7–3.0], but these graphs are enough for approximate estimations of the system loading and, if necessary, for a proper solution for reinforcing.

### System solutions

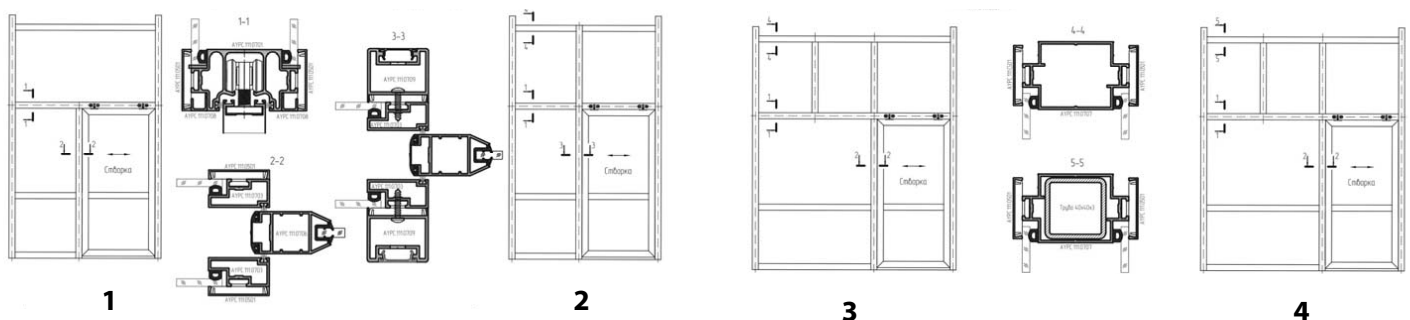

1. The system is not reinforced, the guiding transom bar has three bearing supports.
2. It differs from the solution 1 as to prevent buckling or bending deformation, the central mullion is substantially reinforced with the additional profile which also connects the guiding transom bar with the upper transom. This solution is used when the door mullion weight is more than 120 kg or in case of excessive vibration amplitude of the half mullion according to the customer request.
3. It differs from the solution 1 as the guiding transom bar is attached to the upper reinforced transom bar with the additional mullions. The number of mullions and their location are determined individually, but for systems  $L / \text{edge } W > 2.2$ , the min. recommended amount is 2; one of them should be located as close as possible to the center of the door opening between the central mullion and the edge mullion (see Figure above). If the door leaf weight exceeds 120 kg, it is recommended to reinforce the central mullion with the additional profile just as in solution 2.
4. It differs from solution 3 as the upper transom bar is reinforced with the steel tube 40×40×3. If the door leaf weight exceeds 120 kg, it is recommended to reinforce the central mullion with the additional profile just as in solution 2.

### Intended load

- Weight of the door leaf.
- Weight of the upper infill unit.

During calculation there was determined such a door leaf weight that its impact together with the upper infill unit force to the guiding transom bar could cause its maximum deflection, but not more than 2 mm at different positions of the door leaf (door closed, opened, intermediate position). So, the desired parameter is maximum allowed weight, the calculation stop criterion is the maximum deflection of the guiding transom bar. At the same time the load from the upper infill unit considered to be known value that depends on the initial parameter  $L$  and its distribution depends on the chosen unit option (Finfilling =  $30 L$  [kg] with infill unit on both sides with the glass of 6 mm thick).

## Examples

1. It is necessary to determine the best solution for the system with the project distance between the central axes of the edge mullions equal to  $L = 2480$  mm. The desired width of the door opening is 900 mm, the approximate weight of the door leaf is 40 kg.

The distance between the central axes of the door opening mullions is determined as follows:

$$W = 900 + 40 = 940 \text{ mm.}$$

$$\text{The ratio } L/W = 2480/940 = 2.64.$$

Then we draw the corresponding line on the chart at the intersection point A. We analyze its position in relation to the blue lines lettered  $L = 2.5W$  (the closest variant) and see that the point lies above the line ' $L = 2.5W$  / Solution 1' but below the line ' $L = 2.5W$  / Solution 3'. This means that without reinforcing elements the system is not acceptable. For the proper system functioning it is necessary to use solution 3, connecting the guiding transom bar with the upper additional mullions. The minimum number of extra mullions is 2. One mullion may be the continuation of the central mullion, the other mullion should be located in the middle of the opening, in accordance with the recommendations above.

However, the calculated ratio  $L/W = 2.63 > 2.5$ . By referring to the chart, it can be concluded that the line  $L/W = 2.63$  will lie slightly below the line  $L/W = 2.5$ , respectively, there is a probability that the point A will lie above the line  $L/W = 2.63$ .

In this case, to ensure system reliability it is necessary to apply solution 4 with the upper transom bar reinforced with a steel tube.

2. It is necessary to define the maximum possible weight of the door leaf for a variety of solutions with the given distance between the central axes of the edge mullions  $L = 2200$  mm.

We draw a vertical line through the given value of  $L$ , which crosses the chart line at certain points. Standard system solutions:

- A—with the door opening width of 840 mm, the unit option 1, the maximum permissible weight of the door leaf is 56 kg;
- B—with the door opening width of 940 mm, the unit option 1, the maximum permissible weight of the door leaf is 60 kg;
- C—with the door opening width of 1060 mm, the unit option 1, the maximum permissible weight of the door leaf is 92 kg;
- D—with the door opening width of 840 mm, the unit option 3, the maximum permissible weight of the door leaf is 104 kg;
- E—with the door opening width of 940 mm, the unit option 3, the maximum permissible weight of the door leaf is 115 kg;
- F—with the door opening width of 840 mm, the unit option 4, the maximum permissible weight of the door leaf is 160 kg. This weight is limited by the loading capacity of the bearing rollers.





**ALUTECH ALT 111**  
Interior partition system

# Roller shutters. Installation. Sections

01

02

03

04

05

06

07

08

09

10

11

**12**

13

14



Roller shutters assemblage

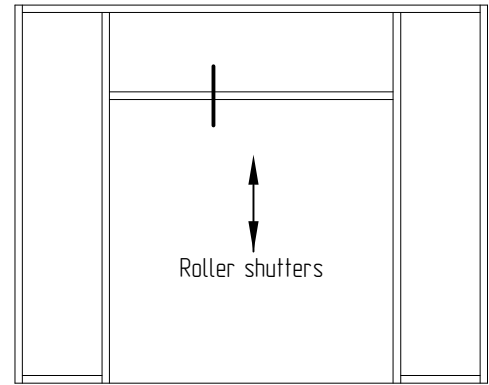
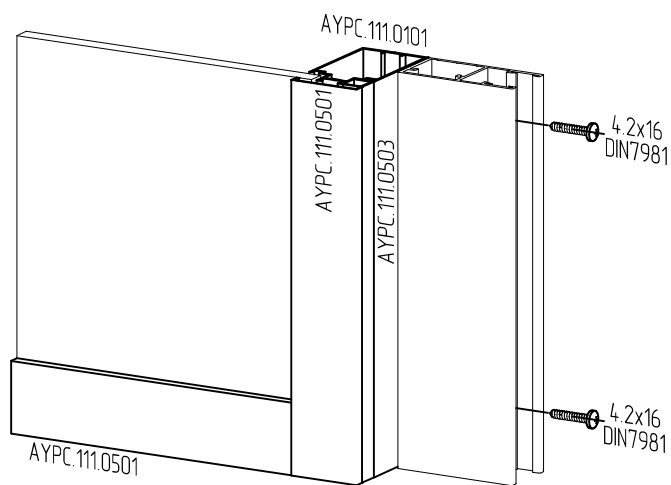
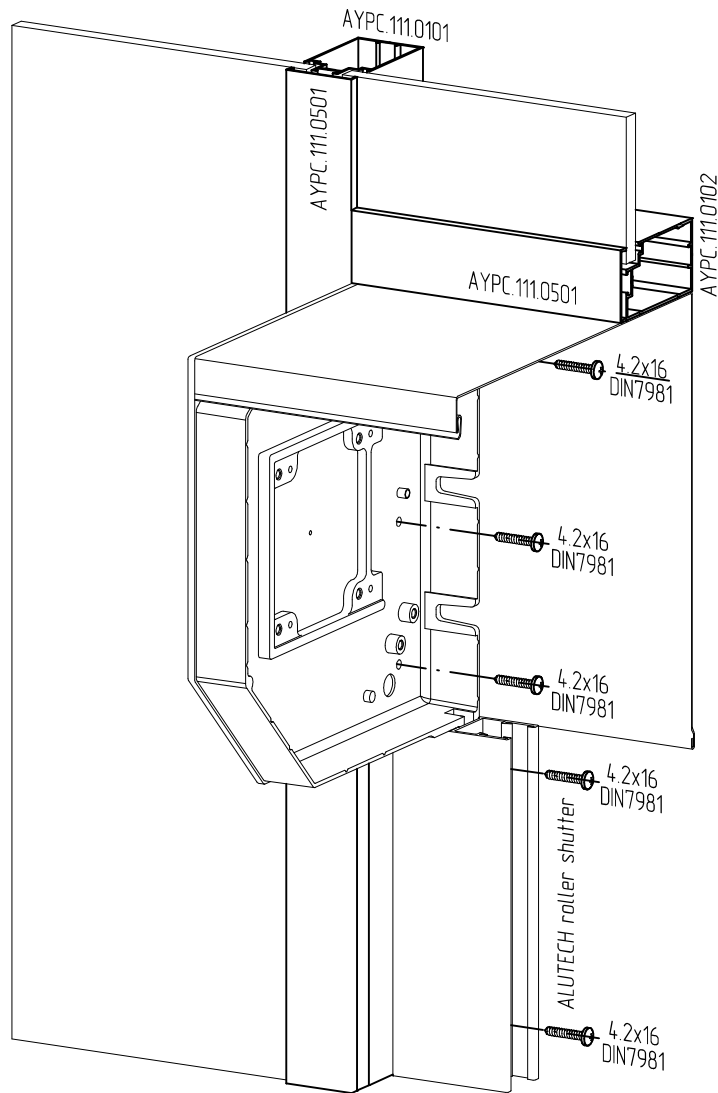

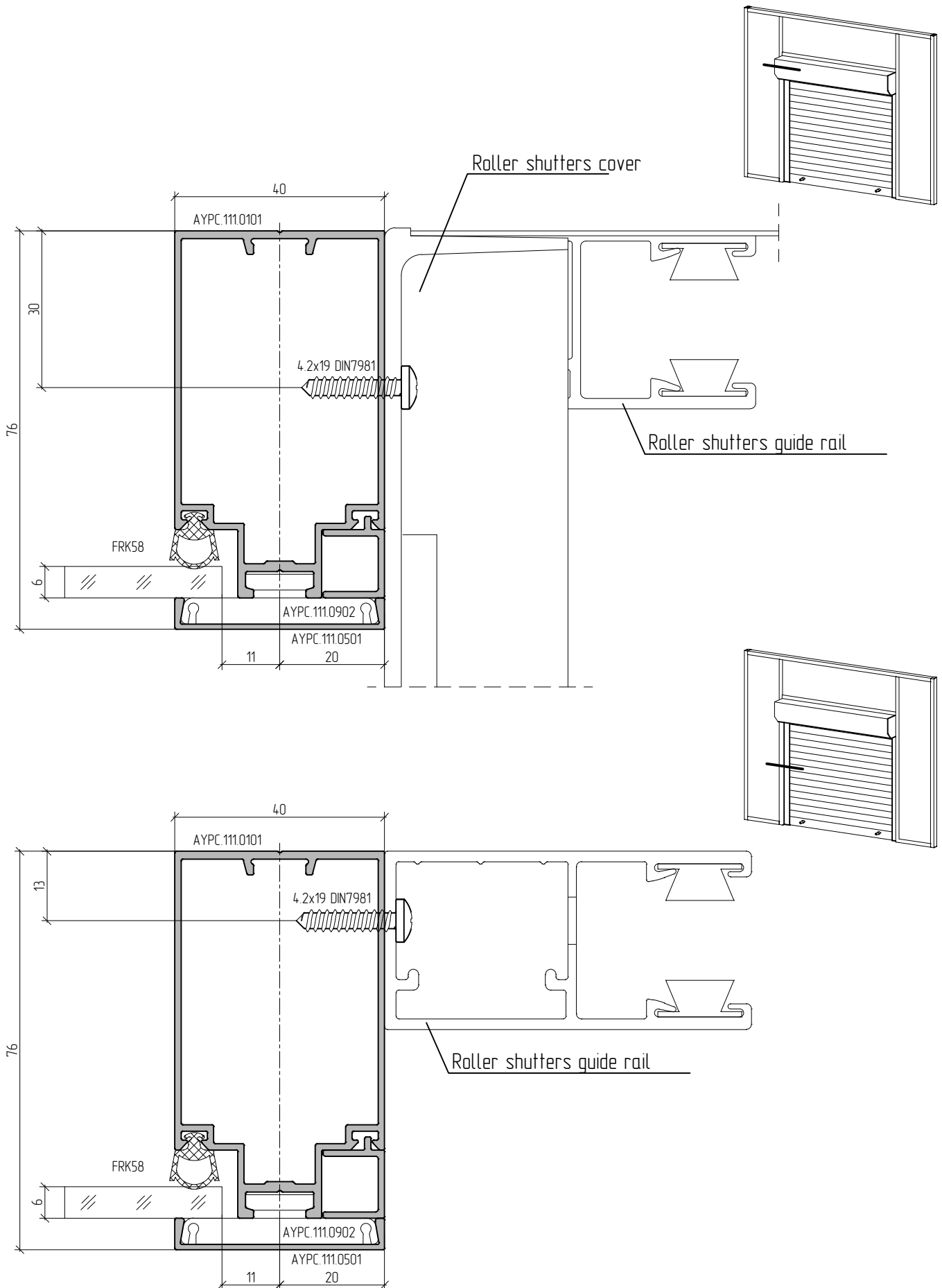





**ALUTECH ALT 111**  
Interior partition system

# Window blind. Installation

01

02

03

04

05

06

07

08

09

10

11

12

**13**

14









**ALUTECH ALT 111**  
Interior partition system

# Statics



The height of partition mullion depending on the distance between them (standard wind pressure of 0.001 kg/cm<sup>2</sup>)

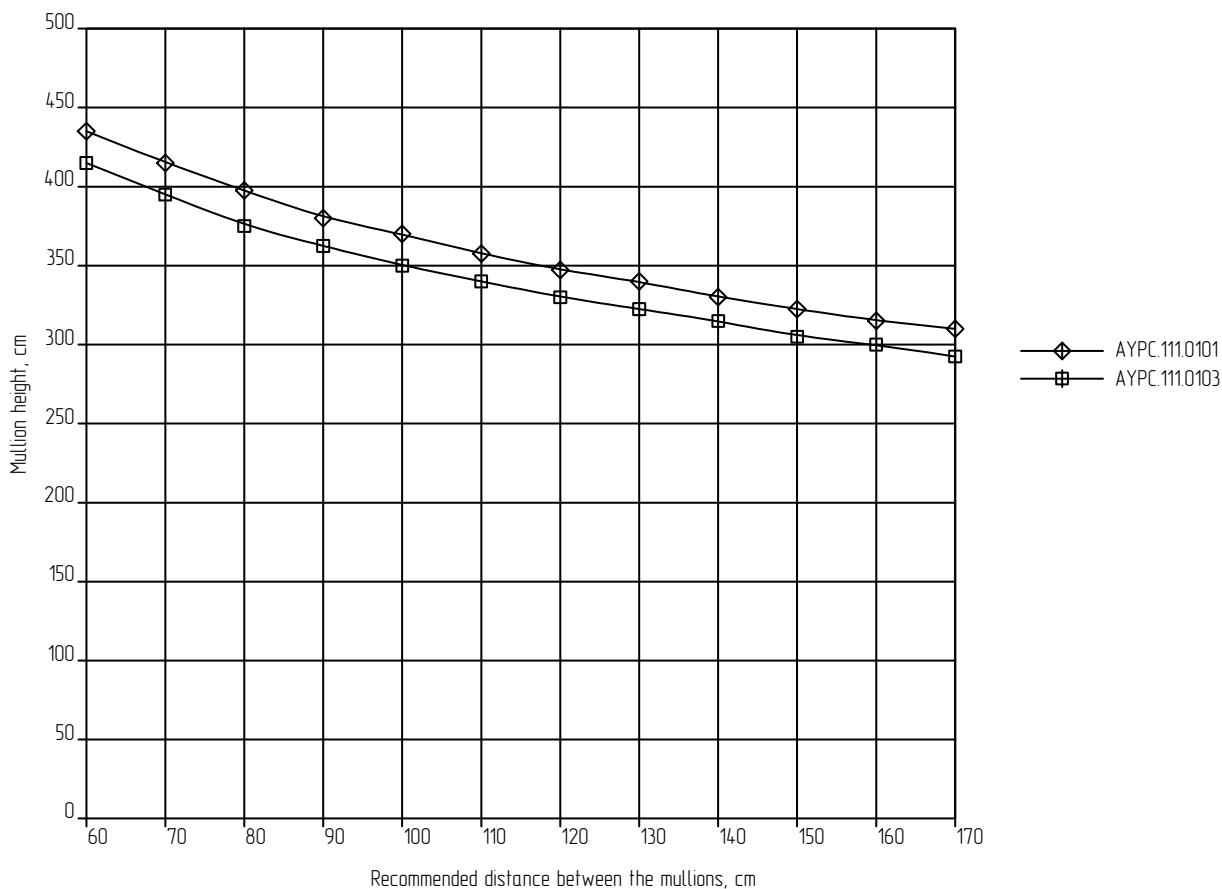

Note: the graph data is a recommended info for ALT111 system profiles.

The calculation method based on the data given in SNiP does not fully take into account features of the real design. There is a situation when a manufacturer of a similar system declares bigger height for its partitions than it's shown in calculations. Comparative analysis of the inertial characteristics of the mullion profiles, given below, will allow to determine the competitiveness of ALT111 partitions.

1. Mullions comparison by radius of inertia r:

$$r = \sqrt{\frac{I_{x(y)}}{S_{\text{profile}}}}$$

where r is geometric characteristic of the profile section, showing the efficiency of material usage, directly proportional to the height, calculated from the flexibility conditions.

2. The relative mullions height by the stiffness conditions:

$$\frac{H_{\text{ALT111}}}{H_{\text{rival}}} = \sqrt{\frac{I_{x(y)\text{ALT111}}}{I_{x(y)\text{rival}}}}$$



**AluminTechno JLLC is a modern highly-effective aluminium extrusion manufacturing enterprise with powder coating and anodizing lines and is a part of ALUTECH Group of Companies.**

The enterprise is equipped with the production facilities of the leading manufacturers from the USA, Italy, Germany, etc. Some technological processes and production equipment elements have no analogues in the CIS countries.

The complete production cycle is being performed at the enterprise: from primary aluminium melting to coating of the extruded profiles. The main manufacturing components are modern foundry complexes, high-tech press lines, advanced powder coating and anodizing shops.

The overall production facilities are:

- foundry complex—more than 55 000 tons per year;
- extrusion complex—more than 50 000 tons per year;
- powder coating lines—more than 45 000 tons per year;
- anodizing workshops—more than 10 000 tons per year.

Currently AluminTechno JLLC produces over 1000 different configurations of aluminium profiles, which are used in construction and motor production, aviation, constructional engineering, electric-power industry, furniture and consumer goods industry.

The company's quality management system and Environmental Management System are certified to the requirements of the international standards (ISO 9001:2015 and ISO 14001:2015) and in TÜV INTERNATIONAL CERTIFICATION system. TÜV certificates are among the most prestigious quality documents recognized worldwide.



Finish quality of aluminium extrusion produced by AluminTechno JLLC is confirmed by three international certificates: Qualicoat/Seaside and Qualanod. AluminTechno is the only aluminium system manufacturer in the CIS countries holding all these certificates.



Anodized aluminum profiles used in architectural construction are also certified to Cradle to Cradle Certified® Silver. It is a registered trademark of the Cradle to Cradle Products Innovation Institute, which confirms the sustainability of the product life cycle.



**AluminTechno JLLC**  
tel.: +375 17 311 05 00  
fax: +375 17 311 05 01  
e-mail: market@alt.by

Certificate № 800017207 issued by  
the Ministry of Foreign Affairs  
of the Republic of Belarus  
03.12.2002 № 800017207